

# Allen-Bradley ControlLogix Ethernet Driver

© 2026 PTC Inc. All Rights Reserved.

# Table of Contents

<b>Allen-Bradley ControlLogix Ethernet Driver</b> .....	<b>1</b>
<b>Table of Contents</b> .....	<b>2</b>
Welcome to the Allen-Bradley ControlLogix Ethernet Driver Help .....	10
<b>Overview</b> .....	<b>11</b>
<b>Setup</b> .....	<b>12</b>
Channel Properties – General .....	14
Tag Counts .....	14
Channel Properties – Ethernet Communications .....	15
Channel Properties – Write Optimizations .....	15
Channel Properties – Advanced .....	16
Device Properties – General .....	16
Operating Mode .....	17
Device Properties – Scan Mode .....	17
Tag Counts .....	18
Device Properties – Timing .....	18
Device Properties – Auto-Demotion .....	19
Device Properties – Tag Generation .....	19
Device Properties – Logix Communications Parameters .....	21
Device Properties – Logix Options .....	22
Device Properties – Logix Database Settings .....	23
Device Properties – ENI DF1/DH+/CN Gateway Communications Parameters .....	24
Block Writes .....	25
Device Properties – SLC 500 Slot Configuration .....	26
Device Properties – Redundancy .....	27
SLC 500 Modular I/O Selection Guide .....	28
Configuration API – Allen-Bradley ControlLogix Ethernet Example .....	31
Enumerations .....	32
Device Model Enumerations .....	33
Configuration API – Slot Configuration .....	34
<b>Automatic Tag Database Generation</b> .....	<b>36</b>
Tag Hierarchy .....	36
Controller-to-Server Name Conversions .....	38
Preparing for Automatic Tag Database Generation .....	39
<b>Performance Optimization</b> .....	<b>40</b>
Optimizing Communications .....	40
Optimizing the Application .....	42
Performance Statistics and Tuning .....	42
Performance Tuning Example .....	43
<b>Data Types Description</b> .....	<b>54</b>
Default Data Type Conditions .....	54
<b>Address Descriptions</b> .....	<b>55</b>

---

Logix Addressing .....	56
MicroLogix Addressing .....	57
SLC 500 Fixed I/O Addressing .....	59
SLC 500 Modular I/O Addressing .....	59
PLC-5 Series Addressing .....	60
Logix Tag-Based Addressing .....	62
Address Formats .....	63
Tag Scope .....	64
Internal Tags .....	65
Predefined Term Tags .....	65
Addressing Atomic Data Types .....	66
Addressing Structure Data Types .....	68
Addressing STRING Data Type .....	68
Ordering of Logix Array Data .....	69
Logix Advanced Addressing .....	70
Advanced Addressing: BOOL .....	70
Advanced Addressing: SINT .....	71
Advanced Addressing: INT .....	73
Advanced Addressing: DINT .....	75
Advanced Addressing: LINT .....	77
Advanced Addressing: REAL .....	79
Advanced Addressing: USINT .....	81
Advanced Addressing: UINT .....	83
Advanced Addressing: UDINT .....	84
Advanced Addressing: ULINT .....	86
Advanced Addressing: LREAL .....	87
Advanced Addressing: TIME32 .....	88
Advanced Addressing: TIME .....	89
Advanced Addressing: LTIME .....	90
File Listing .....	92
Output Files .....	92
Input Files .....	95
Status Files .....	99
Binary Files .....	99
Timer Files .....	100
Counter Files .....	100
Control Files .....	101
Integer Files .....	102
Float Files .....	103
ASCII Files .....	103
String Files .....	104
BCD Files .....	104
Long Files .....	105
MicroLogix PID Files .....	105

---

PID Files .....	106
MicroLogix Message Files .....	108
Message Files .....	109
Block Transfer Files .....	109
Function Files .....	111
High-Speed Counter File (HSC) .....	111
Real-Time Clock File (RTC) .....	112
Channel 0 Communication Status File (CS0) .....	113
Channel 1 Communication Status File (CS1) .....	113
I/O Module Status File (IOS) .....	114
<b>Error Codes .....</b>	<b>115</b>
Encapsulation Error Codes .....	115
CIP Error Codes .....	115
0x0001 Extended Error Codes .....	116
0x001F Extended Error Codes .....	117
0x00FF Extended Error Codes .....	117
<b>Event Log Messages .....</b>	<b>118</b>
The following errors occurred uploading controller project from device. Resorting to Symbolic Protocol.	118
Invalid or corrupt controller project detected while synchronizing. Synchronization will be retried shortly. ....	118
Project download detected while synchronizing. Synchronization will be retried shortly. ....	118
Database error. Data type for reference tag unknown. Setting alias tag data type to default.   Reference tag = '<tag>', Alias tag = '<tag>', Default data type = '<type>'. ....	118
Database error. Member data type not found in tag import file. Setting data type to default.   Member data type = '<type>', UDT = '<type>', Default data type '<type>'. ....	119
Database error. Data type not found in tag import file. Tag not added.   Data type = '<type>', Tag name = '<tag>'. ....	119
Database error. Error occurred processing alias tag. Tag not added.   Alias tag = '<tag>'. ....	119
Database error. Encapsulation error occurred during register session request.   Encapsulation error = <code>. ....	119
Database error. Framing error occurred during register session request. ....	120
Database error. Encapsulation error occurred during fwd. open request.   Encapsulation error = <code>. ....	120
Database error. Framing error occurred during forward open request. ....	120
Database error. Error occurred during forward open request.   CIP error = <code>, Extended error = <code>. ....	120
Database error. Encapsulation error occurred while uploading project information.   Encapsulation error = <code>. ....	120
Database error. Error occurred while uploading project information.   CIP error = <code>, Extended error = <code>. ....	120
Database error. Framing error occurred while uploading project information. ....	121
Database error. Internal error occurred. ....	121
Database error. Encapsulation error occurred while uploading program information.   Program name = '<name>', Encapsulation error = <code>. ....	121
Database error. Error occurred while uploading program information.   Program name = '<name>', CIP error = <code>, Extended error = <code>. ....	121
Database error. Framing error occurred while uploading program information.   Program name =	122

'<name>'. .....	
Database error. Unable to resolve CIP data type for tag. Setting to default type.   CIP data type = <type>, Tag name = '<tag>', Default data type = '<type>'. .....	122
Encapsulation error occurred while uploading project information.   Encapsulation error = <code>. ....	122
Error occurred while uploading project information.   CIP error = <code>, Extended error = <code>. ....	123
Framing error occurred while uploading project information. ....	123
Encapsulation error occurred while uploading program information.   Program name = '<name>', Encapsulation error = <code>. ....	123
Error occurred while uploading program information.   Program name = '<name>', CIP error = <code>, Extended error = <code>. ....	124
Framing error occurred while uploading program information.   Program name = '<name>'. ....	124
Encapsulation error occurred while uploading controller program information. Encapsulation error = <code>. ....	124
Error occurred while uploading controller program information. CIP error = <code>, Extended error = <code>. ....	124
Framing error occurred while uploading controller program information. ....	124
CIP connection timed out while uploading project information. ....	124
Database error. CIP connection timed out while uploading project information. ....	124
Database error. No more connections available for fwd. open request. ....	124
Error opening file for tag database import.   OS error = '<code>'. ....	124
Controller not supported.   Vendor ID = <ID>, Product type = <type>, Product code = <code>, Product name = '<name>'. ....	125
Frame received from device contains errors. ....	125
Write request failed due to a framing error.   Tag address = '<address>'. ....	125
Read request for tag failed due to a framing error.   Tag address = '<address>'. ....	125
Block read request failed due to a framing error.   Block size = <number> (elements), Block start address = '<address>'. ....	126
Block read request failed due to a framing error.   Block size = <number> (bytes), Block name = '<name>'. ....	126
Unable to write to tag.   Tag address = '<address>', CIP error = <code>, Extended error = <code>. ....	126
Unable to read tag.   Tag address = '<address>', CIP error = <code>, Extended error = <code>. ....	127
Unable to read block.   Block size = <number> (elements), Block start address = '<address>', CIP error = <code>, Extended error = <code>. ....	127
Unable to read block.   Block size = <number> (bytes), Tag name = '<tag>', CIP error = <code>, Extended error = <code>. ....	127
Unable to write to tag. Controller tag data type unknown.   Tag address = '<address>', Data type = <type>. ....	127
Unable to read tag. Controller tag data type unknown. Tag deactivated.   Tag address = '<address>', Data type = <type>. ....	127
Unable to read block. Controller tag data type unknown. Block deactivated.   Block size = <number> (elements), Block start address = '<address>', Data type = <type>. ....	128
Unable to write to tag. Data type not supported.   Tag address = '<address>', Data type = <type>. ....	128
Unable to read tag. Data type not supported. Tag deactivated.   Tag address = '<address>', Data type = <type>. ....	128
Unable to read block. Data type not supported. Block deactivated.   Block size = <number> (elements), Block start address = '<address>', Data type = <type>. ....	128
Unable to write to tag. Data type is illegal for this tag.   Tag address = '<address>', Data type = <type>. ....	129
Unable to read tag. Data type is illegal for this tag. Tag deactivated   Tag address = '<address>', Data type = <type>. ....	129

Unable to read block. Data type is illegal for this block. Block deactivated.   Block size = <number> (elements), Block start address = '<address>', Data type = '<type>'.	129
Unable to write to tag. Tag does not support multi-element arrays.   Tag address = '<address>'.	129
Unable to read tag. Tag does not support multi-element arrays. Tag deactivated.   Tag address = '<address>'.	130
Unable to read block. Block does not support multi-element arrays. Block deactivated.   Block size = <number> (elements), Block start address = '<address>'.	130
Unable to write to tag. Native tag size mismatch.   Tag address = '<address>'.	130
Unable to read tag. Native tag size mismatch.   Tag address = '<address>'.	131
Unable to read block. Native tag size mismatch.   Block size = <number> (elements), Block start address = '<address>'.	131
Unable to read block. Native tag size mismatch.   Block size = <number> (bytes), Block name = '<name>'.	131
Unable to write to tag.   Tag address = '<address>'.	131
Unable to read tag. Tag deactivated.   Tag address = '<address>'.	132
Unable to read block. Block deactivated.   Block size = <number> (elements), Block start address = '<address>'.	132
Unable to read block. Block deactivated.   Block size = <number> (bytes), Tag name = '<tag>'.	132
Error occurred during a request to device.   CIP error = <code>, Extended error = <code>.	133
Encapsulation error occurred during a request to device.   Encapsulation error = <code>.	133
Memory could not be allocated for tag.   Tag address = '<address>'.	133
Unable to read block. Frame received contains errors.   Block size = <number> (elements), Starting address = '<address>'.	134
Unable to read function file from device. Frame received contains errors.   Function file = '<name>'.	134
Unable to read block. Tags deactivated.   Block size = <number> (elements), Starting address = '<address>', DF1 status = <code>, Extended status = <code>.	134
Unable to read function file from device. Tags deactivated.   Function file = '<name>', DF1 status = <code>, Extended status = <code>.	134
Unable to write to address. Frame received contains errors.   Address = '<address>'.	135
Unable to write to function file. Frame received contains errors.   Function file = '<name>'.	135
Unable to read block.   Block size = <number> (elements), Starting address = '<address>', DF1 status = <code>, Extended status = <code>.	135
Unable to read function file.   Function file = '<name>', DF1 status = <code>, Extended status = <code>.	135
Unable to read block. Tags deactivated.   Block size = <number> (elements), Starting address = '<address>', DF1 status = <code>, Extended status = <code>.	136
Unable to read function file. Tags deactivated.   Function file = '<name>', DF1 status = <code>.	136
Unable to write to address.   Address = '<address>', DF1 status = <code>, Extended status = <code>.	136
Unable to write to function file.   Function file = '<name>', DF1 status = <code>, Extended status = <code>.	137
Unable to read block.   Block size = <number> (elements), Starting address = '<address>', DF1 status = <code>.	137
Unable to read function file.   Function file = '<name>', DF1 status = <code>.	138
Unable to write to address.   Address = '<address>', DF1 status = <code>.	138
Unable to write to function file.   Function file = '<name>', DF1 status = <code>.	138
Unable to read tag. Internal memory is invalid.   Tag address = '<address>'.	139
Unable to read tag. Data type is illegal for this tag.   Tag address = '<address>', Data type = '<type>'.	139
Unable to read block. Internal memory is invalid. Tag deactivated.   Tag address = '<address>'.	139

Unable to read block. Internal memory is invalid. Block deactivated.   Block size = <number> (elements), Block start address = '<address>'.	139
Unable to write to address. Internal memory is invalid.   Tag address = '<address>'.	139
Unable to read block. Block deactivated.   Block size = <number> (elements), Block start address = '<address>', CIP error = <code>, Extended error = <code>.	139
Device not responding. Local node responded with error.   DF1 status = <code>.	140
Unable to write to function file. Local node responded with error.   Function file = '<name>', DF1 status = <code>.	140
Unable to write to address. Local node responded with error.   Function file = '<name>', DF1 status = <code>.	140
Unexpected offset encountered for tag. Tag will use Symbolic protocol.   Tag address = '<address>'.	140
Unexpected offset encountered for tag.   Tag address = '<address>'.	141
Unexpected offset/span encountered for tag.   Tag address = '<address>'.	141
Project download in progress or no project exists.	141
Project download complete.	141
Project online edit detected. Currently using Symbolic addressing.	141
Project offline edit detected. Currently using Symbolic addressing.	141
The following errors occurred uploading controller project from device. Resorting to symbolic protocol.	141
Unable to retrieve the identity for device. All tags will use Symbolic Protocol.   Encapsulation error = <code>.	141
Unable to retrieve the identity for device. All tags will use Symbolic Protocol.   CIP error = <code>, Extended error = <code>.	141
Unable to retrieve the identity for device. Frame received contains errors. All tags will use Symbolic Protocol.	142
Requested CIP connection size is not supported by this device. Automatically falling back to max. size.   Requested size = <number> (bytes), Max. size = <number> (bytes).	142
The tag import filename is invalid, file paths are not allowed.	142
Read/Write requests to device stopped. Updating Logical Addresses from device project.	143
Read/Write requests to device resumed. Updating Logical Addresses from device complete. Currently using Logical addressing.	143
Unable to write to tag. Value written contains a syntax error.   Tag address = '<address>', Expected format = '<format>'.	143
Unable to write to tag. Value written is out of range.   Tag address = '<address>'.	143
Invalid attributes encountered while uploading program information. All tags for this program will use Symbolic Protocol.   Program name = '<name>'.	143
Database error. Maximum number of supported programs reached. No tags will be created for this program.   Program name = '<name>', Max. programs = <count>.	144
Maximum number of supported programs reached. All tags for this program will use Symbolic Protocol.   Program name = '<name>', Max. programs = <count>.	144
Database status. Importing non-alias tags.	144
Database status. Importing alias tags.	144
Database status. Building tag projects, please wait.   Tag project count = <number>.	144
Database error. Tag renamed because it exceeds max. character length.   Tag name = '<tag>', Max. length = <number>, New tag name = '<tag>'.	144
Database error. Array tags renamed because they exceed max. character length.   Array tags = '<tags>', Max. length = <number>, New array tags = '<tags>'.	144
Database error. Program group name exceeds max. character length. Program group renamed.   Group name = '<name>', Max. length = <number>, New group name = '<name>'.	145
Database status. Retrieving controller project.	145

Database status.   Program count = <number>, Data type count = <number>, Imported tag count = <number>.	145
Database status. Generating OPC tags.	145
Low memory resources.	145
Unknown error occurred.	145
Database status. Importing tags from .L5X file.   Schema revision = '<value>', Software revision = '<value>'.	145
Details.   IP = '<address>', Vendor ID = <vendor>, Product type = <type>, Product code = <code>, Revision= <value>, Product name = '<name>', Product S/N = <number>.	145
Elapsed time = <number> (seconds).	145
Symbolic device reads = <number>.	145
Symbolic, array block device reads = <number>.	145
Symbolic, array block cache reads = <number>.	146
Symbol instance non-block device reads = <number>.	146
Symbol instance non-block, array block device reads = <number>.	146
Symbol instance non-block, array block cache reads = <number>.	146
Symbol instance block device reads = <number>.	146
Symbol instance block cache reads = <number>.	146
Physical non-block device reads = <number>.	146
Physical non-block, array block device reads = <number>.	146
Physical non-block, array block cache reads = <number>.	146
Physical block device reads = <number>.	146
Physical block cache reads = <number>.	146
Tags read = <number>.	146
Packets sent = <number>.	147
Packets received = <number>.	147
Initialization transactions = <number>.	147
Read/Write transactions = <number>.	147
Avg. packets sent/sec = <number>.	147
Avg. packets received/sec = <number>.	147
Avg. tag reads/sec = <number>.	147
Avg. tags/transaction = <number>.	147
-----	147
%s   DEVICE STATISTICS	147
Avg. device turn-around time = <number> (milliseconds)	147
%s   CHANNEL STATISTICS	147
DRIVER STATISTICS	148
Device tag import aborted.	148
Import file '%s' not found at path '%s'.	148
Errors occurred retrieving controller project.	148
Internal driver error occurred.	148
Invalid or corrupt controller project detected while synchronizing. Try again later.	148
Project download detected while synchronizing. Try again later.	148
Low memory resources.	148
L5K file is invalid or corrupt.	148

Unknown error occurred. ....	148
Database error. PLC5/SLC/MicroLogix devices do not support this function. ....	148
L5X file is invalid or corrupt. ....	148
Import file '<empty>' not found at path '<empty>'. ....	149
Import file '%s' not found at path '<empty>'. ....	149
Import file '<empty>' not found at path '%s'. ....	149
XML element failed post-schema validation. Importing tags from device is not supported for model. Use alternative element.   XML element = '{<namespace><element>', Unsupported model = '<model>', Alternative XML element = '{<namespace><element>'. ....	149
Value not supported for an XML element on this model. Automatically setting to new value.   Value = '<value>', XML element = '{<namespace><element>', Model = '<model>', New value = '<value>'. ....	149
<b>Appendices</b> .....	<b>150</b>
Allen-Bradley ControlLogix Ethernet Channel Properties .....	150
Allen-Bradley ControlLogix Ethernet Device Properties .....	150
Allen-Bradley ControlLogix Ethernet Tag Properties .....	153
Logix Device IDs .....	154
CompactLogix 5300 Ethernet Device ID .....	154
1761-NET-ENI Setup .....	155
Data Highway™ Plus Gateway Setup .....	156
ControlNet™ Gateway Setup .....	157
EtherNet/IP Gateway Setup .....	158
Serial Gateway Setup .....	159
MicroLogix 1100 Setup .....	160
Communications Routing .....	160
Connection Path Specification .....	160
Routing Examples .....	162
Choosing a Protocol Mode .....	164
Detecting a Change in the Controller Project .....	166
SoftLogix 5800 Connection Notes .....	167
<b>Index</b> .....	<b>168</b>

---

## Welcome to the Allen-Bradley ControlLogix Ethernet Driver Help

---

This is the user documentation for Kepware Allen-Bradley ControlLogix Ethernet Driver. This help center is updated regularly to reflect the latest functionality and information.

### [Overview](#)

What is the Allen-Bradley ControlLogix Ethernet Driver?

### [Communications Routing](#)

How do I communicate with a remote processor or interface module?

### [Setup](#)

How do I configure a channel and device for use with this driver?

### [Configuration via API](#)

How do I configure a channel and device using the Configuration API?

### [Automatic Tag Database Generation](#)

How can I configure tags for the Allen-Bradley ControlLogix Ethernet Driver?

### [Performance Optimization](#)

How do I get the best performance from the Allen-Bradley ControlLogix Ethernet Driver?

### [Data Types Description](#)

What data types does this driver support?

### [Address Descriptions](#)

How do I address a tag on a Allen-Bradley ControlLogix Ethernet device?

### [Error Codes](#)

What are the Allen-Bradley ControlLogix Ethernet error codes?

### [Event Log Messages](#)

What messages does the driver produce?

### [Appendices](#)

Where can I find additional information relating to the Allen-Bradley ControlLogix Ethernet Driver?

Version 1.199

© 2026 PTC Inc. All Rights Reserved.

---

## Overview

The Allen-Bradley ControlLogix Ethernet Driver provides an easy and reliable way to connect Allen-Bradley ControlLogix Ethernet controllers to OPC client applications, including HMI, SCADA, Historian, MES, ERP, and countless custom applications.

## Supported Allen-Bradley Controllers

### ControlLogix® 5500 Series

Communications with ControlLogix can be accomplished through an EtherNet/IP communication module for Ethernet communications or through a 1761-NET-ENI module for Ethernet-to-serial communications using the controller's serial port.

### CompactLogix™ 5300 and 5400 Series

Ethernet communications with CompactLogix requires a processor with a built-in EtherNet/IP port such as the 1769-L35E. Communications with CompactLogix otherwise requires a 1761-NET-ENI module for Ethernet-to-serial communications using the controller's serial port.

### FlexLogix 5400 Series

Communications with FlexLogix can be accomplished through a 1788-ENBT daughter card for Ethernet communications or through a 1761-NET-ENI module for Ethernet-to-serial communications using the controller's serial port.

### SoftLogix 5800

The driver supports the Allen-Bradley SoftLogix 5800 Series Controller and requires an Ethernet card in the SoftLogix PC.

### Data Highway Plus Gateway

The driver supports the PLC-5 Series and SLC 500 Series with a Data Highway Plus interface. This is accomplished through a DH+ gateway and requires one of the aforementioned PLCs, an EtherNet/IP communication module, and a 1756-DHRIO-interface module (both residing in the ControlLogix rack).

### ControlNet Gateway

The driver supports the PLC-5C Series. This is accomplished through a ControlNet gateway and requires the aforementioned PLC, an EtherNet/IP communication module, and a 1756-CNB/CNBR interface module (both residing in the ControlLogix rack).

### 1761-NET-ENI

The driver supports communications with the 1761-NET-ENI device. The ENI device adds extra flexibility in device networking and communications by providing an Ethernet-to-serial interface for both Full Duplex DF1 controllers and Logix controllers. In conjunction with the ENI device, this driver supports the following:

- ControlLogix 5500 Series\*
- CompactLogix 5300 Series\*
- FlexLogix 5400 Series\*
- MicroLogix Series
- SLC 500 Fixed I/O Processor
- SLC 500 Modular I/O Series
- PLC-5 Series

\*These models require 1761-NET-ENI Series B or higher.

### MicroLogix 1100

The driver supports communications with the MicroLogix 1100 (CH1 Ethernet) using EtherNet/IP.

*ControlLogix is a registered trademarks of Allen-Bradley Company, LLC.  
CompactLogix is a trademarks of Rockwell Automation, Inc.  
All trademarks are the property of their respective owners.*

## Setup

### Channel and Device Limits

The maximum number of channels supported by this driver is 1024. The maximum number of devices supported by this driver is 1024 per channel.

### Supported Devices

Device Family	Communications
ControlLogix 5550 / 5553 / 5555 / 5561 / 5562 / 5563 / 5564 / 5565 / 5571 / 5572 / 5573 / 5574 / 5575 / 5580 processors (including GuardLogix models)	Via 1756-ENBT / ENET / EN2F / EN2T / EN2TR / EN3TR / EWEB / EN2TXT Ethernet module Via Serial Gateway Via 1761-NET-ENI Series B or higher using Channel 0 (serial)
CompactLogix 5320 / 5323 / 5330 / 5331 / 5332 / 5335 / 5343 / 5345 / 5370 / 5380 / 5480 (including GuardLogix models)	Built-in Ethernet/IP port on processors with E suffix* Via Serial Gateway Via 1761-NET-ENI Series B or higher using Channel 0 (serial)
FlexLogix 5433 / 5434 processors	Via 1788-ENBT Ethernet daughter card Via Serial Gateway Via 1761-NET-ENI Series B or higher using Channel 0 (serial)
SoftLogix 5810 / 5830 / 5860 processors	Via SoftLogix Ethernet / IP Messaging module Via Serial Gateway
MicroLogix 1000 / 1200 / 1500	Via 1761-NET-ENI Via EtherNet/IP Gateway
MicroLogix 1100 / 1400	Via MicroLogix 1100 / 1400 Channel 1 (Ethernet) Via 1761-NET-ENI Via EtherNet/IP Gateway
SLC 500 Fixed I/O Processor	Via 1761-NET-ENI Via EtherNet/IP Gateway
SLC 500 Modular I/O Processors (SLC 5/01, SLC 5/02, SLC 5/03, SLC 5/04, SLC 5/05)	Via DH+ Gateway** Via 1761-NET-ENI Via EtherNet/IP Gateway
PLC-5 series (excluding the PLC5/250 series)	Via DH+ Gateway Via 1761-NET-ENI Via EtherNet/IP Gateway
PLC-5/20C, PLC-5/40C, PLC-5/80C	Via ControlNet Gateway Via 1761-NET-ENI Via EtherNet/IP Gateway

\*For example, 1769-L35E.

\*\*This driver supports any SLC 500 series PLC that supports DH+ or that can be interfaced to a DH+ network (such as the KF2 interface module).

### Firmware Versions

Device Family	Version
ControlLogix 5550 (1756-L1)	11.035 - 13.034
ControlLogix 5553 (1756-L53)	11.028
ControlLogix 5555 (1756-L55)	11.032 - 16.004
ControlLogix 5561 (1756-L61)	12.031 - 20.011

Device Family	Version
ControlLogix 5562 (1756-L62)	12.031 - 20.011
ControlLogix 5563 (1756-L63)	11.026 - 20.011
ControlLogix 5564 (1756-L64)	16.003 - 20.011
ControlLogix 5565 (1756-L65)	16.003 - 20.011
ControlLogix 5571 (1756-L71)	20.011 - 37.011
ControlLogix 5572 (1756-L72)	19.011 - 37.011
ControlLogix 5573 (1756-L73)	18.012 - 37.011
ControlLogix 5574 (1756-L74)	19.011 - 37.011
ControlLogix 5575 (1756-L75)	18.012 - 37.011
ControlLogix 5580 (1756-L8)	28.011 - 37.011
CompactLogix 5370 (1769-L1)	20.011 - 37.011
CompactLogix 5370 (1769-L2)	20.011 - 37.011
CompactLogix 5370 (1769-L3)	20.011 - 37.011
CompactLogix 5320 (1769-L20)	11.027 - 13.018
CompactLogix 5323 (1769-L23)	17.005 - 20.011
CompactLogix 5330 (1769-L30)	11.027 - 13.018
CompactLogix 5331 (1769-L31)	16.022 - 20.011
CompactLogix 5332 (1769-L32)	16.022 - 20.011
CompactLogix 5335 (1769-L35)	16.022 - 20.011
CompactLogix 5343 (1768-L43)	15.007 - 20.011
CompactLogix 5345 (1768-L45)	16.024 - 20.011
CompactLogix 5380 (5069-L3)	28.011 - 37.011
CompactLogix 5480 (5069-L4)	32.012 - 37.011
FlexLogix 5433 (1794-L33)	11.025 - 13.033
FlexLogix 5434 (1794-L34)	11.025 - 16.002
SoftLogix 5800 (1789-L60)	16.000 - 20.001
ControlLogix, CompactLogix, and FlexLogix Serial Communications	1761-NET-ENI Series B or higher or Serial Gateway
MicroLogix 1100 (1763-L16AWA/BWA/BBB)	1.1

### Communication Protocol

The Communications Protocol is EtherNet/IP (CIP over Ethernet) using TCP/IP.

### Logix and Gateway Models

Logix and Gateway models support the following:

- Connected Messaging
- Symbolic Reads
- Symbolic Writes
- Symbol Instance Reads (V21 or higher)
- Physical (DMA) Reads (V20 or lower)
- Symbol Instance Writes

### ENI Models

ENI models support unconnected messaging.

## Channel Properties – General

This server supports the use of multiple simultaneous communications drivers. Each protocol or driver used in a server project is called a channel. A server project may consist of many channels with the same communications driver or with unique communications drivers. A channel acts as the basic building block of an OPC link. This group is used to specify general channel properties, such as the identification attributes and operating mode.

Property Groups <b>General</b> Write Optimizations Advanced	<table border="1"> <tr> <td colspan="2">[-] <b>Identification</b></td> </tr> <tr> <td>Name</td> <td></td> </tr> <tr> <td>Description</td> <td></td> </tr> <tr> <td>Driver</td> <td></td> </tr> <tr> <td colspan="2">[-] <b>Diagnostics</b></td> </tr> <tr> <td>Diagnostics Capture</td> <td>Disable</td> </tr> <tr> <td colspan="2">[-] <b>Tag Counts</b></td> </tr> <tr> <td>Static Tags</td> <td>10</td> </tr> </table>	[-] <b>Identification</b>		Name		Description		Driver		[-] <b>Diagnostics</b>		Diagnostics Capture	Disable	[-] <b>Tag Counts</b>		Static Tags	10
[-] <b>Identification</b>																	
Name																	
Description																	
Driver																	
[-] <b>Diagnostics</b>																	
Diagnostics Capture	Disable																
[-] <b>Tag Counts</b>																	
Static Tags	10																

### Identification

**Name:** Specify the user-defined identity of this channel. In each server project, each channel name must be unique. Although names can be up to 256 characters, some client applications have a limited display window when browsing the OPC server's tag space. The channel name is part of the OPC browser information. The property is required for creating a channel.

• For information on reserved characters, refer to "How To... Properly Name a Channel, Device, Tag, and Tag Group" in the server help.

**Description:** Specify user-defined information about this channel.

• Many of these properties, including Description, have an associated system tag.

**Driver:** Specify the protocol / driver for this channel. Specify the device driver that was selected during channel creation. It is a disabled setting in the channel properties. The property is required for creating a channel.

• **Note:** With the server's online full-time operation, these properties can be changed at any time. This includes changing the channel name to prevent clients from registering data with the server. If a client has already acquired an item from the server before the channel name is changed, the items are unaffected. If, after the channel name has been changed, the client application releases the item and attempts to re-acquire using the old channel name, the item is not accepted. Changes to the properties should not be made once a large client application has been developed. Utilize proper user role and privilege management to prevent operators from changing properties or accessing server features.

### Diagnostics

**Diagnostics Capture:** When enabled, this option makes the channel's diagnostic information available to OPC applications. Because the server's diagnostic features require a minimal amount of overhead processing, it is recommended that they be utilized when needed and disabled when not. The default is disabled.

• **Note:** This property is not available if the driver or operating system does not support diagnostics.

• For more information, refer to *Communication Diagnostics and Statistics Tags* in server help.

### Tag Counts

**Static Tags:** Provides the total number of defined static tags at this level (device or channel). This information can be helpful in troubleshooting and load balancing.

## Channel Properties – Ethernet Communications

Ethernet Communication can be used to communicate with devices.

Property Groups	[-] <b>Ethernet Settings</b>	
General	Network Adapter	Default
<b>Ethernet Communications</b>		
Write Optimizations		
Advanced		

### Ethernet Settings

**Network Adapter:** Specify the network adapter to bind. When left blank or Default is selected, the operating system selects the default adapter.

## Channel Properties – Write Optimizations

The server must ensure that the data written from the client application gets to the device on time. Given this goal, the server provides optimization properties to meet specific needs or improve application responsiveness.

Property Groups	[-] <b>Write Optimizations</b>	
General	Optimization Method	Write Only Latest Value for All Tags
<b>Write Optimizations</b>	Duty Cycle	10

### Write Optimizations

**Optimization Method:** Controls how write data is passed to the underlying communications driver. The options are:

- **Write All Values for All Tags:** This option forces the server to attempt to write every value to the controller. In this mode, the server continues to gather write requests and add them to the server's internal write queue. The server processes the write queue and attempts to empty it by writing data to the device as quickly as possible. This mode ensures that everything written from the client applications is sent to the target device. This mode should be selected if the write operation order or the write item's content must uniquely be seen at the target device.
- **Write Only Latest Value for Non-Boolean Tags:** Many consecutive writes to the same value can accumulate in the write queue due to the time required to actually send the data to the device. If the server updates a write value that has already been placed in the write queue, far fewer writes are needed to reach the same final output value. In this way, no extra writes accumulate in the server's queue. When the user stops moving the slide switch, the value in the device is at the correct value at virtually the same time. As the mode states, any value that is not a Boolean value is updated in the server's internal write queue and sent to the device at the next possible opportunity. This can greatly improve the application performance.
  - **Note:** This option does not attempt to optimize writes to Boolean values. It allows users to optimize the operation of HMI data without causing problems with Boolean operations, such as a momentary push button.
- **Write Only Latest Value for All Tags:** This option takes the theory behind the second optimization mode and applies it to all tags. It is especially useful if the application only needs to send the latest value to the device. This mode optimizes all writes by updating the tags currently in the write queue before they are sent. This is the default mode.

**Duty Cycle:** is used to control the ratio of write to read operations. The ratio is always based on one read for every one to ten writes. The duty cycle is set to ten by default, meaning that ten writes occur for each read operation. Although the application is performing a large number of continuous writes, it must be ensured that read data is still given time to process. A setting of one results in one read operation for every write operation. If there are no write operations to perform, reads are processed continuously. This allows optimization for applications with continuous writes versus a more balanced back and forth data flow.

• **Note:** It is recommended that the application be characterized for compatibility with the write optimization enhancements before being used in a production environment.

## Channel Properties – Advanced

This group is used to specify advanced channel properties. Not all drivers support all properties; so the Advanced group does not appear for those devices.

Property Groups	<input type="checkbox"/> <b>Non-Normalized Float Handling</b>	
General	Floating-Point Values	Replace with Zero
Write Optimizations	<input type="checkbox"/> <b>Inter-Device Delay</b>	
<b>Advanced</b>	Inter-Device Delay (ms)	0

**Non-Normalized Float Handling:** A non-normalized value is defined as Infinity, Not-a-Number (NaN), or as a Denormalized Number. The default is Replace with Zero. Drivers that have native float handling may default to Unmodified. Non-normalized float handling allows users to specify how a driver handles non-normalized IEEE-754 floating point data. Descriptions of the options are as follows:

- **Replace with Zero:** This option allows a driver to replace non-normalized IEEE-754 floating point values with zero before being transferred to clients.
- **Unmodified:** This option allows a driver to transfer IEEE-754 denormalized, normalized, non-number, and infinity values to clients without any conversion or changes.

● **Note:** This property is disabled if the driver does not support floating-point values or if it only supports the option that is displayed. According to the channel's float normalization setting, only real-time driver tags (such as values and arrays) are subject to float normalization. For example, EFM data is not affected by this setting.

● *For more information on the floating-point values, refer to "How To ... Work with Non-Normalized Floating-Point Values" in the server help.*

**Inter-Device Delay:** Specify the amount of time the communications channel waits to send new requests to the next device after data is received from the current device on the same channel. Zero (0) disables the delay.

● **Note:** This property is not available for all drivers, models, and dependent settings.

## Device Properties – General

Property Groups	<input type="checkbox"/> <b>Identification</b>	
<b>General</b>	Name	ENI: SLC 500 Modular I/O
Scan Mode	Description	
Timing	Driver	Allen-Bradley ControlLogix Ethernet
Auto-Demotion	Model	ENI: SLC 500 Modular I/O
Tag Generation	Channel Assignment	Allen-Bradley ControlLogix Ethernet
Logix Communication Parameters	ID	<255.25.255.2>
Logix Options	<input type="checkbox"/> <b>Operating Mode</b>	
Logix Database Settings	Data Collection	Enable
ENI DF1/DH+/CN Gtwy Comm...	Simulated	No
Slot Configuration	<input type="checkbox"/> <b>Tag Counts</b>	
Redundancy	Static Tags	1

### Identification

**Name:** User-defined identity of this device.

**Description:** User-defined information about this device.

**Channel Assignment:** User-defined name of the channel to which this device currently belongs.

**Driver:** Selected protocol driver for this device.

**Model:** The specific version of the device.

**Tip:** Use ControlLogix or CompactLogix for GuardLogix (see [Supported Devices](#)).

**ID:** Enter the unique network address of the device, typically in the format of <IP or hostname>,1, <routing path>,<slot>.

*The conventions for addressing vary by model and routing. For more information, refer to the model-specific addressing topics under [Reference Material](#).*

## Operating Mode

Property Groups	+ Identification	
General	- Operating Mode	
	Data Collection	Enable
	Simulated	No

**Data Collection:** This property controls the device's active state. Although device communications are enabled by default, this property can be used to disable a physical device. Communications are not attempted when a device is disabled. From a client standpoint, the data is marked as invalid and write operations are not accepted. This property can be changed at any time through this property or the device system tags.

**Simulated:** Place the device into or out of Simulation Mode. In this mode, the driver does not attempt to communicate with the physical device, but the server continues to return valid OPC data. Simulated stops physical communications with the device, but allows OPC data to be returned to the OPC client as valid data. While in Simulation Mode, the server treats all device data as reflective: whatever is written to the simulated device is read back and each OPC item is treated individually. The item's memory map is based on the group Update Rate. The data is not saved if the server removes the item (such as when the server is reinitialized). The default is No.

### Notes:

- Updates are not applied until clients disconnect and reconnect.
- The System tag (`_Simulated`) is read only and cannot be written to for runtime protection. The System tag allows this property to be monitored from the client.
- In Simulation mode, the item's memory map is based on client update rate(s) (Group Update Rate for OPC clients or Scan Rate for native and DDE interfaces). This means that two clients that reference the same item with different update rates return different data.
- When a device is simulated, updates may not appear faster than one (1) second in the client.

Simulation Mode is for test and simulation purposes only. It should never be used in a production environment.

## Device Properties – Scan Mode

The Scan Mode specifies the subscribed-client requested scan rate for tags that require device communications. Synchronous and asynchronous device reads and writes are processed as soon as possible; unaffected by the Scan Mode properties.

Property Groups	- Scan Mode	
General	Scan Mode	Respect Client-Specified Scan Rate ▾
Scan Mode	Initial Updates from Cache	Disable

**Scan Mode:** Specify how tags in the device are scanned for updates sent to subscribing clients. Descriptions of the options are:

- Respect Client-Specified Scan Rate:** This mode uses the scan rate requested by the client.
- Request Data No Faster than Scan Rate:** This mode specifies the value set as the maximum scan rate. The valid range is 10 to 99999990 milliseconds. The default is 1000 milliseconds.
  - Note:** When the server has an active client and items for the device and the scan rate value is increased, the changes take effect immediately. When the scan rate value is decreased, the changes do not take effect until all client applications have been disconnected.

- **Request All Data at Scan Rate:** This mode forces tags to be scanned at the specified rate for subscribed clients. The valid range is 10 to 99999990 milliseconds. The default is 1000 milliseconds.
- **Do Not Scan, Demand Poll Only:** This mode does not periodically poll tags that belong to the device nor perform a read to get an item's initial value once it becomes active. It is the OPC client's responsibility to poll for updates, either by writing to the `_DemandPoll` tag or by issuing explicit device reads for individual items. *For more information, refer to "Device Demand Poll" in server help.*
- **Respect Tag-Specified Scan Rate:** This mode forces static tags to be scanned at the rate specified in their static configuration tag properties. Dynamic tags are scanned at the client-specified scan rate.

**Initial Updates from Cache:** When enabled, this option allows the server to provide the first updates for newly activated tag references from stored (cached) data. Cache updates can only be provided when the new item reference shares the same address, scan rate, data type, client access, and scaling properties. A device read is used for the initial update for the first client reference only. The default is disabled; any time a client activates a tag reference the server attempts to read the initial value from the device.

## Tag Counts

Property Groups	<input type="checkbox"/> Identification <input type="checkbox"/> Operating Mode <input checked="" type="checkbox"/> Tag Counts	
General	Static Tags	130

**Static Tags:** Provides the total number of defined static tags at this level (device or channel). This information can be helpful in troubleshooting and load balancing.

## Device Properties – Timing

The device Timing properties allow the driver's response to error conditions to be tailored to fit the application's needs. In many cases, the environment requires changes to these properties for optimum performance. Factors such as electrically generated noise, modem delays, and poor physical connections can influence how many errors or timeouts a communications driver encounters. Timing properties are specific to each configured device.

Property Groups	<input checked="" type="checkbox"/> Communication Timeouts	
General	Connect Timeout (s)	3
Scan Mode	Request Timeout (ms)	1000
Timing	Attempts Before Timeout	3

## Communications Timeouts

**Connect Timeout:** This property (which is used primarily by Ethernet based drivers) controls the amount of time required to establish a socket connection to a remote device. The device's connection time often takes longer than normal communications requests to that same device. The valid range is 1 to 30 seconds. The default is typically 3 seconds, but can vary depending on the driver's specific nature. If this setting is not supported by the driver, it is disabled.

● **Note:** Due to the nature of UDP connections, the connection timeout setting is not applicable when communicating via UDP.

**Request Timeout:** Specify an interval used by all drivers to determine how long the driver waits for a response from the target device to complete. The valid range is 50 to 9999999 milliseconds (167 minutes). The default is usually 1000 milliseconds, but can vary depending on the driver. The default timeout for most serial drivers is based on a baud rate of 9600 baud or better. When using a driver at lower baud rates, increase the timeout to compensate for the increased time required to acquire data.

**Attempts Before Timeout:** Specify how many times the driver issues a communications request before considering the request to have failed and the device to be in error. The valid range is 1 to 10. The default is typically 3, but can vary depending on the driver's specific nature. The number of attempts configured for an application

depends largely on the communications environment. This property applies to both connection attempts and request attempts.

## Timing

**Inter-Request Delay:** Specify how long the driver waits before sending the next request to the target device after receiving the response to the previous request. It overrides the normal polling frequency of tags associated with the device, as well as one-time reads and writes. This delay can be useful when dealing with devices with slow turn-around times and in cases where network load is a concern. Configuring a delay for a device affects communications with all other devices on the channel. It is recommended that users separate any device that requires an inter-request delay to a separate channel if possible. Other communications properties (such as communication serialization) can extend this delay. The valid range is 0 to 300,000 milliseconds; however, some drivers may limit the maximum value due to a function of their particular design. The default is 0, which indicates no delay between requests with the target device.

● **Note:** Not all drivers support Inter-Request Delay. This setting does not appear if it is not available.

Property Groups	<input type="checkbox"/> <b>Timing</b>	
General	Inter-Request Delay (ms)	0
Scan Mode		
<b>Timing</b>		

## Device Properties – Auto-Demotion

The Auto-Demotion properties can temporarily place a device off-scan in the event that a device is not responding. By placing a non-responsive device offline for a specific time period, the driver can continue to optimize its communications with other devices on the same channel. After the time period has been reached, the driver re-attempts to communicate with the non-responsive device. If the device is responsive, the device is placed on-scan; otherwise, it restarts its off-scan time period.

Property Groups	<input type="checkbox"/> <b>Auto-Demotion</b>	
General	Demote on Failure	Enable ▾
Scan Mode	Timeouts to Demote	3
Timing	Demotion Period (ms)	10000
<b>Auto-Demotion</b>	Discard Requests when Demoted	Disable

**Demote on Failure:** When enabled, the device is automatically taken off-scan until it is responding again.

● **Tip:** Determine when a device is off-scan by monitoring its demoted state using the `_AutoDemoted` system tag.

**Timeouts to Demote:** Specify how many successive cycles of request timeouts and retries occur before the device is placed off-scan. The valid range is 1 to 30 successive failures. The default is 3.

**Demotion Period:** Indicate how long the device should be placed off-scan when the timeouts value is reached. During this period, no read requests are sent to the device and all data associated with the read requests are set to bad quality. When this period expires, the driver places the device on-scan and allows for another attempt at communications. The valid range is 100 to 3600000 milliseconds. The default is 10000 milliseconds.

**Discard Requests when Demoted:** Select whether or not write requests should be attempted during the off-scan period. Disable to always send write requests regardless of the demotion period. Enable to discard writes; the server automatically fails any write request received from a client and does not post a message to the Event Log.

## Device Properties – Tag Generation

The automatic tag database generation features make setting up an application a plug-and-play operation. Select communications drivers can be configured to automatically build a list of tags that correspond to device-specific data. These automatically generated tags (which depend on the nature of the supporting driver) can be browsed from the clients.

● *Not all devices and drivers support full automatic tag database generation and not all support the same data types. Consult the data types descriptions or the supported data type lists for each driver for specifics.*

If the target device supports its own local tag database, the driver reads the device's tag information and uses the data to generate tags within the server. If the device does not natively support named tags, the driver creates a list of tags based on driver-specific information. An example of these two conditions is as follows:

1. If a data acquisition system supports its own local tag database, the communications driver uses the tag names found in the device to build the server's tags.
2. If an Ethernet I/O system supports detection of its own available I/O module types, the communications driver automatically generates tags in the server that are based on the types of I/O modules plugged into the Ethernet I/O rack.

● **Note:** Automatic tag database generation's mode of operation is completely configurable. *For more information, refer to the property descriptions below.*

Property Groups	Tag Generation	
General	On Device Startup	Do Not Generate on Startup
Timing	On Duplicate Tag	Delete on Create
Auto-Demotion	Parent Group	
<b>Tag Generation</b>	Allow Automatically Generated Subgroups	Enable
Communications	Create	Create tags
Redundancy		

**On Property Change:** If the device supports automatic tag generation when certain properties change, the **On Property Change** option is shown. It is set to **Yes** by default, but it can be set to **No** to control over when tag generation is performed. In this case, the **Create tags** action must be manually invoked to perform tag generation.

**On Device Startup:** Specify when OPC tags are automatically generated. Descriptions of the options are as follows:

- **Do Not Generate on Startup:** This option prevents the driver from adding any OPC tags to the tag space of the server. This is the default setting.
- **Always Generate on Startup:** This option causes the driver to evaluate the device for tag information. It also adds tags to the tag space of the server every time the server is launched.
- **Generate on First Startup:** This option causes the driver to evaluate the target device for tag information the first time the project is run. It also adds any OPC tags to the server tag space as needed.

● **Note:** When the option to automatically generate OPC tags is selected, any tags that are added to the server's tag space must be saved with the project. Users can configure the project to automatically save from the **Tools | Options** menu.

**On Duplicate Tag:** When automatic tag database generation is enabled, the server needs to know what to do with the tags that it may have previously added or with tags that have been added or modified after the communications driver since their original creation. This setting controls how the server handles OPC tags that were automatically generated and currently exist in the project. It also prevents automatically generated tags from accumulating in the server.

For example, if a user changes the I/O modules in the rack with the server configured to **Always Generate on Startup**, new tags would be added to the server every time the communications driver detected a new I/O module. If the old tags were not removed, many unused tags could accumulate in the server's tag space. The options are:

- **Delete on Create:** This option deletes any tags that were previously added to the tag space before any new tags are added. This is the default setting.
- **Overwrite as Necessary:** This option instructs the server to only remove the tags that the communications driver is replacing with new tags. Any tags that are not being overwritten remain in the server's tag space.
- **Do not Overwrite:** This option prevents the server from removing any tags that were previously generated or already existed in the server. The communications driver can only add tags that are completely new.
- **Do not Overwrite, Log Error:** This option has the same effect as the prior option and also posts an error message to the server's Event Log when a tag overwrite would have occurred.

● **Note:** Removing OPC tags affects tags that have been automatically generated by the communications driver as well as any tags that have been added using names that match generated tags. Users should avoid adding tags to the server using names that may match tags that are automatically generated by the driver.

**Parent Group:** This property keeps automatically generated tags from mixing with tags that have been entered manually by specifying a group to be used for automatically generated tags. The name of the group can be up to 256 characters. This parent group provides a root branch to which all automatically generated tags are added.

**Allow Automatically Generated Subgroups:** This property controls whether the server automatically creates subgroups for the automatically generated tags. This is the default setting. If disabled, the server generates the device's tags in a flat list without any grouping. In the server project, the resulting tags are named with the address value. For example, the tag names are not retained during the generation process.

● **Note:** If, as the server is generating tags, a tag is assigned the same name as an existing tag, the system automatically increments to the next highest number so that the tag name is not duplicated. For example, if the generation process creates a tag named "AI22" that already exists, it creates the tag as "AI23" instead.

**Create:** Initiates the creation of automatically generated OPC tags. If the device's configuration has been modified, **Create tags** forces the driver to reevaluate the device for possible tag changes. Its ability to be accessed from the System tags allows a client application to initiate tag database creation.

● **Note:** **Create tags** is disabled if the Configuration edits a project offline.

## Device Properties – Logix Communications Parameters

Property Groups	<input type="checkbox"/> <b>EtherNet/IP</b>	
General	TCP/IP Port	44818
Scan Mode	<input type="checkbox"/> <b>CIP</b>	
Timing	Connection Size (bytes)	500
Auto-Demotion	Inactivity Watchdog (s)	32
Tag Generation	<input type="checkbox"/> <b>Logix</b>	
<b>Logix Comm. Parameters</b>	Array Block Size	120
Logix Options		
Logix Database Settings		
ENI DF1/DH+/CN Gtwy Comm....		
Redundancy		

### EtherNet/IP

**TCP/IP Port:** Specifies the TCP/IP port number that the device is configured to use. The default is 44818.

### CIP

**Connection Size:** Specify the number of bytes available on the CIP connection for data requests and responses. The valid range is 500 to 4000 bytes. The default is 500 bytes.

● **Note:** Only the ControlLogix 5500 and CompactLogix 5300 device models support this feature. To support connection sizes greater than 500 bytes, the device must support Firmware version 20 or later controllers and Ethernet bridge EN3x, EN2x, or EN5.x. Older Ethernet modules like ENBT and ENET do not support this feature. Devices that do not meet the necessary requirements automatically fall back to the default setting of 500 bytes, although the requested size is re-attempted after communications failure.

● *The Connection Size value may also be requested through the System tag "\_CIPConnectionSizeRequested."* For more information, refer to [Internal Tags](#).

**Inactivity Watchdog:** Specify the amount of time, in seconds, a connection remains idle (without read/write transactions) before being closed by the controller. The larger the value, the more time it takes for connection resources to be released by the controller and vice versa. The default is 32 seconds.

● **Note:** If an error about the CIP connection timing out while uploading a project occurs frequently, increase the Inactivity Watchdog value. Otherwise, the default value is suggested.

### Logix

**Array Block Size:** This property specifies the maximum number of array elements to read in a single transaction. The value is adjustable and ranges from 30 to 3840 elements. The default is 120 elements.

**Tip:** For Boolean arrays, a single element is considered a 32-element bit array. Setting the block size to 30 elements translates to 960-bit elements, whereas 3840 elements translate to 122880 bit elements.

## Device Properties – Logix Options

Property Groups	<input checked="" type="checkbox"/> <b>Protocol Options</b>	
General	Protocol Mode	Logical Non-Blocking
Scan Mode	Synchronize After Online Edits	Yes
Timing	Synchronize After Offline Edits	Yes
Auto-Demotion	Terminate String Data at LEN	Enable
Tag Generation	<input checked="" type="checkbox"/> <b>Project Options</b>	
Logix Communication Parameters	Default Data Type	Default
<b>Logix Options</b>	Performance Statistics	Disable
Logix Database Settings		
ENI DF1/DH+/CN Gtwy Comm...		
Slot Configuration		
Redundancy		

### Protocol Options

**Protocol Mode:** Select how Logix tag data is read from the controller: Logical Non-Blocking, Logical Blocking, and Symbolic. The default is Logical Non-Blocking. This option should only be changed by advanced users looking to increase client / server tag update performance.

**Tip:** For more information, refer to [Choosing a Protocol Mode](#).

**Note:** Logical Non-Blocking and Logical Blocking are not available to Serial Gateway models.

**Synchronize After Online Edits:** When enabled, the driver synchronizes its project image with that of the controller project when an online project edit (or project download from RSLogix/Studio5000) is detected. This option prevents unnecessary errors from occurring during a project change. It is only available when the selected Protocol Mode is Logical Non-Blocking or Logical Blocking. The default is Yes.

**Synchronize After Offline Edits:** When enabled, the driver synchronizes its own project image with that of the controller project when an offline project edit (or project download from RSLogix/Studio5000) is detected. This option prevents unnecessary errors from occurring during a project change. It is only available when the selected protocol is Logical Non-Blocking or Logical Blocking. The default is Yes.

**Failure:** Failure to synchronize with project changes can lead to reading from and writing to the wrong Native Tag address.

**Terminate String Data at LEN:** When enabled, the driver automatically reads the LEN member of the STRING structure whenever the DATA member is read. The DATA string is terminated at the first null character encountered, the character whose position equals the value of LEN, or the maximum string length of DATA (whichever occurs first). When disabled, the driver bypasses the LEN member read and terminates the DATA string at either the first null character encountered or the maximum string length of DATA (whichever occurs first). Therefore, if LEN is reduced by an external source without modification to DATA, the driver does not terminate DATA according to this reduced length. The default is Enable.

### Project Options

**Default Data Type:** Select the data type assigned to a client/server tag when the default type is selected during tag addition, modification, or import. The default is Default.

**Tip:** For more information, refer to [Default Data Type Conditions](#).

**Performance Statistics:** The Allen-Bradley ControlLogix Ethernet Driver has the ability to gather communication statistics to help determine the driver's performance. The driver tracks the number and types of client/server tag updates. On restart of the server application, the results are displayed in the server's Event Log. The default is Disable.

**Note:** Once a project configuration is designed for optimal performance, it is recommended that users disable Performance Statistics. Because the statistics are written to the Event Log on shutdown, the server must be re-launched to view the results.

**See Also:** [Detecting a Change in the Controller Project](#)

## Device Properties – Logix Database Settings

Property Groups	Database Import Method	
General	Database Import Method	Create from Device
Scan Mode	Tag Import File	*.l5k
Timing	Tag Descriptions	Enable
Auto-Demotion	Logix Database Options	
Tag Generation	Limit Name Length	Disable
Logix Communication Parameters	Tag Hierarchy	Expanded
Logix Options	Logix Database Filtering	
<b>Logix Database Settings</b>	Impose Array Limit	Disable
ENI DF1/DH+/CN Gtwy Comm...	Array Count Upper Limit	2000
Slot Configuration		
Redundancy		

### Database Import Method

**Database Import Method:** Select how the tag database should be populated:

- **Create from Device:** retrieves tags directly from the controller over the same Ethernet connection that is used for data access, which is fast and imports most tags, but requires access to the controller and does not import descriptions. Tags that are not imported include Add-On Instruction (AOI) InOut properties.
  - **Note:** This feature is not available to Serial Gateway models.
- **Create from Import File:** retrieves tags from a selected RSLogix L5K/L5X file. Controller access is not necessary, descriptions are imported, and users can work offline; however, this option is slower and does not import all the tags in the controller. Tags that are not imported include:
  - I/O tags
  - Add-On Instruction (AOI) InOut properties
  - AOI properties that alias other properties
  - Equipment Phase properties that alias properties from another Equipment Phase or Program
  - Program properties that alias properties from another Program or Equipment Phase
  - Timer / Counter CTL bits

**Tag Import File:** Click the browse (...) button to locate and select the L5K/L5X file from which tags are to be imported. This file is used when Automatic Tag Database Generation is instructed to create the tag database. All tags, including Global and Program, are imported and expanded according to their respective data types.

**Tag Descriptions:** Choose **Enable** to import tag descriptions for non-structure, non-array tags. If necessary, a description is given to tags with long names stating the original tag name.

### Tag Generation Using the API

The config API properties for CLX offline ATG are:

```
"controllogix_ethernet.DEVICE_DATABASE_IMPORT_METHOD": 1, "controllogix_ethernet.DEVICE_TAG_IMPORT_FILE": "myFile.l5x", "controllogix_ethernet.DEVICE_DISPLAY_DESCRIPTIONS": true,
```

where the enumeration for import method is:

0 for Create from Device;

and

1 for Create from File

### Logix Database Options

**Limit Name Length:** Set to Enable to constrain the tag and group names to 31 characters. The default is **Disable**.

1. Before OPC server version 4.70, tag and group name lengths were restricted to 31 characters. The current length restriction of 256 characters can fit Logix 40-character Logix Tag names.
2. If an older server version was used to import tags via L5K/L5X import, inspect the Event Log or scan the server project to see if any tags were truncated due to the character limit. If so, Enable this property to preserve the server tag names. OPC client tag references are not affected. If disabled, longer tag names are created and clients referencing the clipped tag must be changed to reference the new tag name.
3. If an older OPC server version was used to import tags via L5K/L5X import and no tags were truncated due to the 31-character limit, leave this option disabled.
4. If tags were imported via L5K/L5X with server version 4.70 or above, leave this option disabled.

• **See Also:** [Controller-to-Server Name Conversions](#)

**Tag Hierarchy:** This property specifies the tree organization of the tag hierarchy. When **Condensed**, the server tags created by automatic tag generation follow a group/tag hierarchy consistent with the tag's address. Groups are created for every segment preceding the period. When **Expanded**, the server tags created by automatic tag generation follow a group/tag hierarchy consistent with the tag hierarchy in RSLogix 5000. Groups are created for every segment preceding the period and to represent logical groupings. To use this functionality, enable **Allow Sub Groups** in [Tag Generation](#) properties.

• For more information on the groups created, refer to [Tag Hierarchy](#) and [Controller-to-Server Name Conversions](#).

## Logix Database Filtering

**Impose Array Limit:** Select Enable to constrain the number of array elements. Tags in the controller can be declared with very large array dimensions. By default, arrays are completely expanded during the tag generation process, which becomes time consuming for large arrays. By imposing a limit, only a specified number of elements from each dimension are generated. Limits only takes effect when the array dimension size exceeds the limit. The default is **Disable**.

**Array Count Upper Limit:** Specify the array count limit. The default is 2000.

## Device Properties – ENI DF1/DH+/CN Gateway Communications Parameters

Property Groups	<input checked="" type="checkbox"/> <b>ENI DF1/DH+/CN Gtwy Communication Parameters</b>	
General	TCP/IP Port	44818
Scan Mode	Request Size (bytes)	232
Timing	Allow Function File Block Writes	Disable
Auto-Demotion		
Tag Generation		
Logix Communication Parameters		
Logix Options		
Logix Database Settings		
<b>ENI DF1/DH+/CN Gtwy C...</b>		
Slot Configuration		
Redundancy		

**TCP/IP Port:** Specify the port number that the remote device is configured to use (such as 1756-ENBT). The default is 44818.

**Request Size:** Select the number of bytes that may be requested from a device at one time to refine performance. Options are 32, 64, 128, or 232. The default is 232 bytes.

**Allow Function File Block Writes:** Function files are structure-based files (much like PD and MG data files) and are unique to the MicroLogix 1100, 1200, and 1500. For applicable function files, data can be written to the device in a single operation. By default, when data is written to a function file sub element (field within the function file structure), a write operation occurs immediately for that tag. For such files as the RTC file, whose sub elements include hour (HR), minute (MIN), and second (SEC), individual writes are not always acceptable. With such sub elements

relying solely on time, values must be written in one operation to avoid time elapsing between sub elements writes. For this reason, there is the option to block write these sub elements. The default is disabled.

• For more information, refer to [Block Writes](#) and [Function Files](#).

## Block Writes

Block writing involves writing to the device the values of every read/write sub element in the function file in a single write operation. It is not necessary to write to every sub element before performing a block write. Sub elements that are not affected (written to) have their current value written back to them. For example, if the current (last read) date and time is 1/1/2001, 12:00.00, DOW = 3 and the hour is changed to 1 o'clock, the values written to the device are 1/1/2001, 1:00.00, DOW = 3. For more information, refer to the instructions below.

1. To start, locate **ENI DF1/DH+/CN Gateway Communications Parameters** in **Device Properties**.
2. Enable **Allow Function Files Block Writes** to notify the driver to utilize block writes on function files that support block writes.
3. Clicking **OK** or **Apply**.
4. Write the desired value to the sub element tag in question. The sub element tag immediately takes on the value written to it.

• **Note:** After a sub element is written to at least once in block write mode, the tag's value does not originate from the controller, but instead from the driver's write cache. After the block write is done, all sub element tag values originate from the controller.

5. Once the entire desired sub elements are written, perform the block write that sends these values to the controller. To instantiate a block write, reference tag address *RTC:<element>.\_SET*. Setting this tag's value to 'true' causes a block write to occur based on the current (last read) sub elements and the sub elements affected (written to). Immediately after setting the tag to 'true', it is automatically reset to "false." This is the default state and performs no action.

## Applicable Function Files / Sub Elements

RTC	
Year	YR
Month	MON
Day	DAY
Day of Week	DOW
Hour	HR
Minute	MIN
Second	SEC

• **See Also:** [Function File Listing](#)

## Device Properties – SLC 500 Slot Configuration

For I/O to be accessed, SLC5/01/02/03/04/05 models (modular I/O racks) must be configured for use with the Allen-Bradley ControlLogix Ethernet Driver. Up to 30 slots can be configured per device.

Property Groups General Scan Mode Timing Auto-Demotion Tag Generation Logix Communication Parameters Logix Options Logix Database Settings ENI DF1/DH+/CN Gtwy Comm... <b>Slot Configuration</b> Redundancy	<input type="checkbox"/> <b>Slot 1</b> Module <No Module>
	<input type="checkbox"/> <b>Slot 2</b> Module <No Module>
	<input type="checkbox"/> <b>Slot 3</b> Module <No Module>
	<input type="checkbox"/> <b>Slot 4</b> Module <No Module>
	<input type="checkbox"/> <b>Slot 5</b> Module <No Module>
	<input type="checkbox"/> <b>Slot 6</b> Module <No Module>
	<input type="checkbox"/> <b>Slot 7</b> Module <No Module>
	<input type="checkbox"/> <b>Slot 8</b> Module <No Module>
	<input type="checkbox"/> <b>Slot 9</b> Module <No Module>

**Slot *n***: the physical slot being configured. Use the plus icon to expand the properties.

**Module**: Set the type of module in the slot from the options available in the drop-down list.

• To configure slots through the [Configuration API Service, see this example](#).

**Input Words**: If required by the module selected, enter the maximum number of Input Words for this module.

**Output Words**: If required by the module selected, enter the maximum number of Output Words for this module.

To use slot configuration, follow the instructions below:

1. Select the slot to be configured by clicking on the row in the module list box.
2. To select a module, click on it from the available modules drop-down list.
3. Configure the Input Words and Output Words if necessary.
4. To remove a slot / module, select **No Module** from the available modules drop-down list.
5. When complete, click **OK**.

### • Tips:

- Use the 0000-Generic Module to configure I/O that is not contained in the list of Available Modules.
- The module selections available are the same as those in the Allen Bradley APS software.

• **Note**: It is common to have open slots in the rack that do not contain a physical module. To correctly access data for the various slots that do contain a module, the preceding module(s) must have the correct number of words mapped. For example, if only interested in the I/O in slot 3, but slots 1 and 2 contain I/O modules, the correct modules must be selected for slots 1, 2, and 3 from this slot configuration group.

### 0000-Generic Module

Use the Generic Module to map Input and Output words for modules that are not represented in the list of available modules. To correctly use the Generic Module, users must know the number of Input and Output words required for each module.

• Consult Allen-Bradley I/O user manual documentation to confirm Input and Output requirements and be aware that requirements may be different based on Class 1 or Class 3 operation.

• For information on the number of input and output words available for each I/O module, refer to [Modular I/O Selection Guide](#).

## Device Properties – Redundancy

---

Property Groups	<input type="checkbox"/> <b>Redundancy</b>	
General	Secondary Path	<b>Channel.Device 1</b> ...
Scan Mode	Operating Mode	Switch On Failure
Timing	Monitor Item	
Auto-Demotion	Monitor Interval (s)	300
<b>Redundancy</b>	Return to Primary ASAP	Yes

Redundancy is available with the Media-Level Redundancy Plug-In.

• Consult the website, a sales representative, or the [user manual](#) for more information.

## SLC 500 Modular I/O Selection Guide

The following table lists the number of input and output words available for each I/O module in the Slot Configuration list.

Module ID	Module Type	Input Words	Output Words
0	1746-I*8 Any 8 pt Discrete Input Module	1	0
1	1746-I*16 Any 16 pt Discrete Input Module	1	0
2	1746-I*32 Any 32 pt Discrete Input Module	2	0
3	1746-O*8 Any 8 pt Discrete Output Module	0	1
4	1746-O*16 Any 16 pt Discrete Output Module	0	1
5	1746-O*32 Any 32 pt Discrete Output Module	0	2
6	1746-IA4 4 Input 100 / 120 VAC	1	0
7	1746-IA8 8 Input 100 / 120 VAC	1	0
8	1746-IA16 16 Input 100/120 VAC	1	0
9	1746-IB8 8 Input (Sink) 24 VDC	1	0
10	1746-IB16 16 Input (Sink) 24 VDC	1	0
11	1746-IB32 32 Input (Sink) 24 VDC	2	0
12	1746-IG16 16 Input [TTL] (Source) 5 VDC	1	0
13	1746-IM4 4 Input 200 / 240 VAC	1	0
14	1746-IM8 8 Input 200 / 240 VAC	1	0
15	1746-IM16 16 Input 200/240 VAC	1	0
16	1746-IN16 16 Input 24 VAC / VDC	1	0
17	1746-ITB16 16 Input [Fast] (Sink) 24 VDC	1	0
18	1746-ITV16 16 Input [Fast] (Source) 24 VDC	1	0
19	1746-IV8 8 Input (Source) 24 VDC	1	0
20	1746-IV16 16 Input (Source) 24 VDC	1	0
21	1746-IV32 32 Input (Source) 24 VDC	2	0
22	1746-OA8 8 Output (TRIAC) 100 / 240 VAC	0	1
23	1746-OA16 16 Output (TRIAC) 100 / 240 VAC	0	1
24	1746-OB8 8 Output [Trans] (Source) 10 / 50 VDC	0	1
25	1746-OB16 16 Output [Trans] (Source) 10 / 50 VDC	0	1
26	1746-OB32 32 Output [Trans] (Source) 10/50 VDC	0	2
27	1746-OBP16 16 Output [Trans 1 Amp] (SRC) 24 VDC	0	1
28	1746-OV8 8 Output [Trans] (Sink) 10/50 VDC	0	1
29	1746-OV16 16 Output [Trans] (Sink) 10/50 VDC	0	1
30	1746-OV32 32 Output [Trans] (Sink) 10/50 VDC	0	2
31	1746-OW4 4 Output [Relay] VAC/VDC	0	1
32	1746-OW8 8 Output [Relay] VAC/VDC	0	1
33	1746-OW16 16 Output [Relay] VAC/VDC	0	1
34	1746-OX8 8 Output [Isolated Relay] VAC/VDC	0	1
35	1746-OVP16 16 Output [Trans 1 Amp] (Sink) 24 VDC3	0	1
36	1746-IO4 2 In 100 / 120 VAC 2 Out [Rly] VAC / VDC3	1	1
37	1746-IO8 4 In 100 / 120 VAC 4 Out [Rly] VAC / VDC4	1	1
38	1746-IO12 6 In 100 / 120 VAC 6 Out [Rly] VAC / VDC	1	1
39	1746-NI4 4 Ch Analog Input	4	0
40	1746-NIO4I Analog Comb 2 in & 2 Current Out	2	2

Module ID	Module Type	Input Words	Output Words
41	1746-NIO4V Analog Comb 2 in & 2 Voltage Out	2	2
42	1746-NO4I 4 Ch Analog Current Output	0	4
43	1746-NO4V 4 Ch Analog Voltage Output	0	4
44	1746-NT4 4 Ch Thermocouple Input Module	8	8
45	1746-NR4 4 Ch Rtd / Resistance Input Module	8	8
46	1746-HSCE High-Speed Counter/Encoder	8	1
47	1746-HS Single Axis Motion Controller	4	4
48	1746-OG16 16 Output [TLL] (SINK) 5 VDC	0	1
49	1746-BAS Basic Module 500 5/01 Configuration	8	8
50	1746-BAS Basic Module 5/02 Configuration	8	8
51	1747-DCM Direct Communication Module (1/4 Rack)	2	2
52	1747-DCM Direct Communication Module (1/2 Rack)	4	4
53	1747-DCM Direct Communication Module (3/4 Rack)	6	6
54	1747-DCM Direct Communication Module (Full Rack)	8	8
55	1747-SN Remote I/O Scanner	32	32
56	1747-DSN Distributed I/O Scanner 7 Blocks	8	8
57	1747-DSN Distributed I/O Scanner 30 Blocks	32	32
58	1747-KE Interface Module, Series A	1	0
59	1747-KE Interface Module, Series B	8	8
60	1746-NI8 8 Ch Analog Input, Class 1	8	8
61	1746-NI8 8 Ch Analog Input, Class 3	16	12
62	0000-Generic Module	-	-
63	1746-IC16 16 Input (Sink) 48 VDC	1	0
64	1746-IH16 16 Input [Trans] (Sink) 125 VDC	1	0
65	1746-OAP12 12 Output [Triac] 120/240 VDC	0	1
66	1746-OB6EI 6 Output [Trans] (Source) 24 VDC	0	1
67	1746-OB16E 16 Output [Trans] (Source) Protected	0	1
68	1746-OB32E 32 Output [Trans] (Source) 10 / 50 VDC	0	2
69	1746-OBP8 8 Output [Trans 2 amp] (Source) 24 VDC	0	1
70	1746-IO12DC 6 Input 12 VDC, 6 Output [Rly]	1	1
71	1746-INI4I Analog 4 Ch. Isol. Current Input	8	8
72	1746-INI4VI Analog 4 Ch. Isol. Volt/Current Input	8	8
73	1746-INO4I Analog 4 Ch. Isol. Current Output	8	8
74	1746-INO4VI Analog 4 Ch. Isol. Volt/Current Output	8	8
75	1746-INT4 4 Ch. Isolated Thermocouple Input	8	8
76	1746-NT8 Analog 8 Ch Thermocouple Input	8	8
77	1746-HSRV Motion Control Module	12	8
78	1746-HSTP1 Stepper Controller Module	8	8
79	1747-MNET MNET Network Comm Module	0	0
80	1746-QS Synchronized Axes Module	32	32
81	1747-QV Open Loop Velocity Control	8	8
82	1747-RCIF Robot Control Interface Module	32	32
83	1747-SCNR ControlNet SLC Scanner	32	32
84	1747-SDN DeviceNet Scanner Module	32	32
85	1394-SJT GMC Turbo System	32	32

---

Module ID	Module Type	Input Words	Output Words
86	1203-SM1 SCANport Comm Module - Basic	8	8
87	1203-SM1 SCANport Comm Module - Enhanced	32	32
88	AMCI-1561 AMCI Series 1561 Resolver Module	8	8

## Configuration API – Allen-Bradley ControlLogix Ethernet Example

For a list of channel and device definitions and enumerations, access the following endpoints with the REST client or refer to the appendices.

### Channel Definitions

Endpoint (GET):

```
https://<hostname_or_ip>:<port>/config/v1/doc/drivers/Allen-Bradley%20ControlLogix%20Ethernet/channels
```

### Device Definitions

Endpoint (GET):

```
https://<hostname_or_ip>:<port>/config/v1/doc/drivers/Allen-Bradley%20ControlLogix%20Ethernet/devices
```

### Create Allen-Bradley ControlLogix Ethernet Channel

Endpoint (POST):

```
https://<hostname_or_ip>:<port>/config/v1/project/channels
```

Body:

```
{
  "common.ALLTYPES_NAME": "MyChannel",
  "servermain.MULTIPLE_TYPES_DEVICE_DRIVER": "Allen-Bradley ControlLogix Ethernet"
}
```

• **See Also:** [Appendix](#) for a list of channel properties.

### Create Allen-Bradley ControlLogix Ethernet Device

Endpoint (POST):

```
https://<hostname_or_ip>:<port>/config/v1/project/channels/MyChannel/devices
```

Body:

```
{
  "common.ALLTYPES_NAME": "MyDevice",
  "servermain.DEVICE_ID_STRING": "<IP Address>,0,1",
  "servermain.MULTIPLE_TYPES_DEVICE_DRIVER": "Allen-Bradley ControlLogix Ethernet",
  "servermain.DEVICE_MODEL": <model enumeration>
}
```

where <IP Address> is the device's IP address.

• **Note:** The format of the value for servermain.DEVICE\_ID\_STRING may vary depending on the model enumeration specified for servermain.DEVICE\_MODEL. The device ID string format shown above is for the ControlLogix 5500 model.

• **See Also:** [Device Model Enumerations](#) and [Device Properties](#).

### Create Allen-Bradley ControlLogix Ethernet Tags

Endpoint (POST):

```
https://<hostname_or_ip>:<port>/config/v1/project/channels/MyChannel/devices/MyDevice/tags
```

Body:

```
[
  {
    "common.ALLTYPES_NAME": "MyTag1",
    "servermain.TAG_ADDRESS": "My_Tag_Address"
  }
]
```

```

}
{
  "common.ALLTYPES_NAME": "MyTag2",
  "servermain.TAG_ADDRESS": "My_Tag_Address"
}
]

```

• **See Also:** [Appendix](#) for a list of tag properties.

• See server and driver-specific help for more information on configuring tags and tag groups using the Configuration API.

## Enumerations

Some properties, such as Device Model, have values that are mapped to an enumeration. A valid list of enumerations and their values can be found by querying the device endpoint with 'content=property\_definitions' or the documentation definitions endpoints.

For example, to view the property definitions for a device named "MyDevice" under a channel named "MyChannel", the GET request would be sent to:

```

https://<hostname_or_ip>:<-
port>/config/v1/project/channels/MyChannel/devices/MyDevice/?content=property_definitions

```

Property definitions are also available for other objects such as channels or tags.

Alternatively, if enabled in the settings for the Configuration API, the channel and device property definitions for the driver can be viewed at:

```

https://<hostname_or_ip>:<port>/config/v1/doc/drivers/<drivername>/Channels

```

```

https://<hostname_or_ip>:<port>/config/v1/doc/drivers/<drivername>/Devices

```

## Example Data Type Enumerations

Querying the documentation endpoint for tag data types provides the following enumerations:

```

{
  "Default": -1,
  "String": 0,
  "Boolean": 1,
  "Char": 2,
  "Byte": 3,
  "Short": 4,
  "Word": 5,
  "Long": 6,
  "DWord": 7,
  "Float": 8,
  "Double": 9,
  "BCD": 10,
  "LBCD": 11,
  "Date": 12,
  "LLong": 13,
  "QWord": 14,
  "String Array": 20,
  "Boolean Array": 21,
  "Char Array": 22,
  "Byte Array": 23,
  "Short Array": 24,
  "Word Array": 25,
  "Long Array": 26,

```

```

"DWord Array": 27,
"Float Array": 28,
"Double Array": 29,
"BCD Array": 30,
"LBCD Array": 31,
"Date Array": 32,
"LLong Array": 33,
"QWord Array": 34
}

```

● **Note:** Supported data types vary by protocol and driver.

### Device Model Enumerations

The Device Model property has values mapped to the following enumerations. The below table is for reference only; the information at the device endpoint is the complete and current source of information:

```

https://<hostname_or_ip>:<port>/config/v1/doc/drivers/Allen-Brad-
ley%20ControlLogix%20Ethernet/Channels

```

```

https://<hostname_or_ip>:<port>/config/v1/doc/drivers/Allen-Brad-
ley%20ControlLogix%20Ethernet/Devices

```

Enumeration	Device Model
0	ControlLogix 5500
1	CompactLogix 5300
2	FlexLogix 5400
3	SoftLogix 5800
4	DH+ Gateway: PLC-5
5	DH+ Gateway: SLC 5/04
6	ControlNet Gateway: PLC-5C
7	EIP Gateway: MicroLogix
8	EIP Gateway: SLC Fixed
9	EIP Gateway: SLC Modular
10	EIP Gateway: PLC-5
11	Serial Gateway: ControlLogix
12	Serial Gateway: CompactLogix
13	Serial Gateway: CompactLogix
14	Serial Gateway: FlexLogix
15	Serial Gateway: SoftLogix
16	ENI: ControlLogix 5500
17	ENI: FlexLogix 5400
18	ENI: MicroLogix
19	ENI: SLC 500 Fixed I/O
20	ENI: SLC 500 Modular I/O
21	ENI: PLC-5
22	MicroLogix 1100
23	MicroLogix 1400





## Automatic Tag Database Generation

The Allen-Bradley ControlLogix Ethernet Driver can be configured to automatically generate a list of server tags within the server that correspond to device-specific data. The automatically generated tags are based on the Logix tags defined in the Logix device, and can be browsed from the OPC client. Logix tags can be atomic or structured. Structure and array tags can quickly increase the number of tags imported (and therefore the number of tags available in the server).

● **Note:** ENI/DH+, ControlNet Gateway, and MicroLogix models do not support automatic tag database generation: only ENI ControlLogix, CompactLogix, and FlexLogix models do.

Atomic Tag -> **one-to-one** -> Server Tag  
 Structure Tag -> **one-to-many** -> Server Tags  
 Array Tag -> **one-to-many** -> Server Tags

● For more information on the Database Creation settings, refer to the server help file.

● **Note:** Controller tags observed in the RSLogix5000 programming environment must have the "External Access" property configured to "Read Only" or "Read/Write" for the tags to be read. Automatically generated tags may set External Access to "None" by default. To read controller tags, reconfigure External Access as needed in the Add-On Instruction Parameters of RSLogix. *Consult the manufacturer documentation.*

## Tag Hierarchy

The server tags created by automatic tag generation can follow one of two hierarchies: Expanded or Condensed. To use this functionality, enable Allow Sub Groups in device properties.

### Expanded Mode

When Expanded, the server tags created by automatic tag generation follow a group / tag hierarchy consistent with the tag hierarchy in RSLogix 5000. Groups are created for every segment preceding the period as when Condensed, but are also created in logical groupings. Groups created include the following:

- Global (controller) scope
- Program scope
- Structures and substructures
- Arrays

● **Note:** Groups are not created for .bit addresses.

The root-level groups (or subgroup levels of the group specified in Parent Group) are "Prgm\_<program name>" and "Global". Each program in the controller has its own "Prgm\_<program name>" group. The driver recognizes this as the first group level.

Basic Global Tags (or non-structure, non-array tags) are placed under the Global group; basic Program tags are placed under their respective program group. Each structure and array tag is provided in its own subgroup of the parent group. By organizing the data in this fashion, the server's tag view mimics RSLogix5000.

The name of the structure / array subgroup also provides a description of the structure / array. For instance, an array tag1[1,6] defined in the controller would have a subgroup name "tag1\_x\_y"; x signifies dimension 1 exists, and y signifies dimension 2 exists. The tags within an array subgroup are all the elements of that array (unless explicitly limited). The tags within a structure subgroup are the structure members themselves. If a structure contains an array, an array subgroup of the structure group is created as well.

With a complex project, the tag hierarchy can require a number of group levels. The maximum number of group levels created by automatic tag generation is seven. This does not include the group specified in "Add generated tags to the following group". When more than seven levels are required, the tags are placed in the seventh group (causing the hierarchy to plateau).

### Array Tags

A group is created for each array that contains the array's elements. Group names have the notation: <array name>\_x\_y\_z where:

x\_y\_z = 3 dimensional array

x\_y = 2 dimensional array  
 x = 1 dimensional array

Array tags have the notation: <tag element>\_XXXXX\_YYYYY\_ZZZZZ. For example, element tag1[12,2,987] would have the tag name "tag1\_12\_2\_987".

### Simple Example

Name	Value	Force Mask	Style	Data Type
MyTag	{...}	{...}		MyDataType
MyTag.Member1	{...}	{...}	Decimal	DINT[10]
MyTag.Member1[0]	0		Decimal	DINT
MyTag.Member1[1]	0		Decimal	DINT
MyTag.Member1[2]	0		Decimal	DINT
MyTag.Member1[3]	0		Decimal	DINT

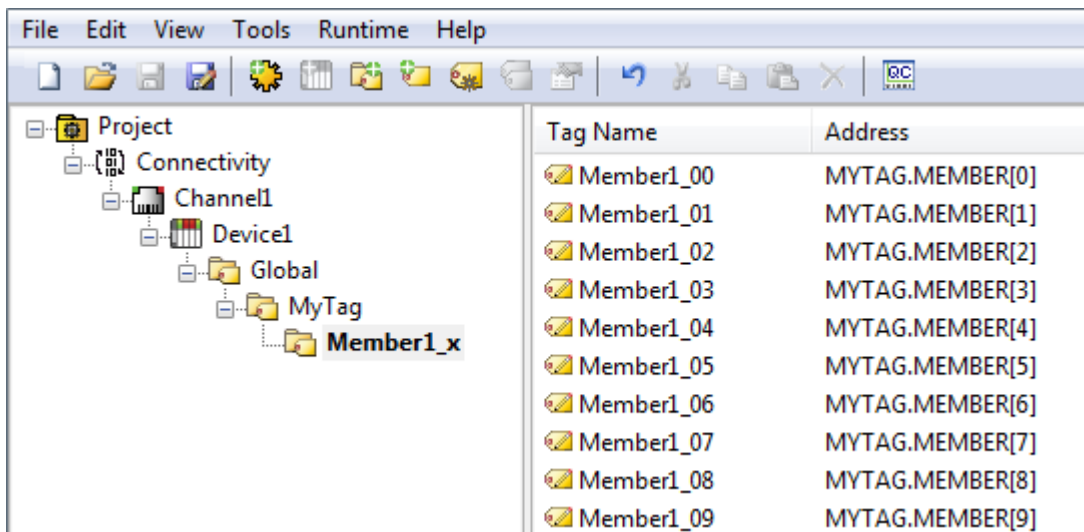

### Complex Example

A Logix tag is defined with the address "Local:1:O.Slot[9].Data". This would be represented in the groups "Global" - "Local\_1\_O" - "Slot\_x" - "Slot\_09". Within the last group would be the tag "Data".

The static reference to "Data" would be "Channel1.Device1.Global.Local\_1\_O.Slot\_x.Slot\_09.Data". The dynamic reference to "Data" would be "Channel1.Device1.Local:1:O.Slot[9].Data".

### Condensed Mode

In Condensed Mode, the server tags created by automatic tag generation follow a group/tag hierarchy consistent with the tag's address. Groups are created for every segment preceding the period. Groups created include the following:

- Program scope
- Structures and substructures

● **Note:** Groups are not created for arrays or .bit addresses.

With a complex project, it is easy to see how the tag hierarchy can require a number of group levels. The maximum number of group levels created by automatic tag generation is seven. This does not include the group specified in "Add generated tags to the following group". When more than seven levels are required, the tags are placed in the seventh group (causing the hierarchy to plateau).

● **Note:** Tag or structure member names leading off with an underscore is converted to "U\_". This is required because the server does not support leading underscores. For more information, refer to [Controller-to-Server Name Conversion](#).

### Simple Example

Name	Value	Force Mask	Style	Data Type
MyTag	{...}	{...}		MyDataType
MyTag.Member1	{...}	{...}	Decimal	DINT[10]
MyTag.Member1[0]	0		Decimal	DINT
MyTag.Member1[1]	0		Decimal	DINT
MyTag.Member1[2]	0		Decimal	DINT
MyTag.Member1[3]	0		Decimal	DINT

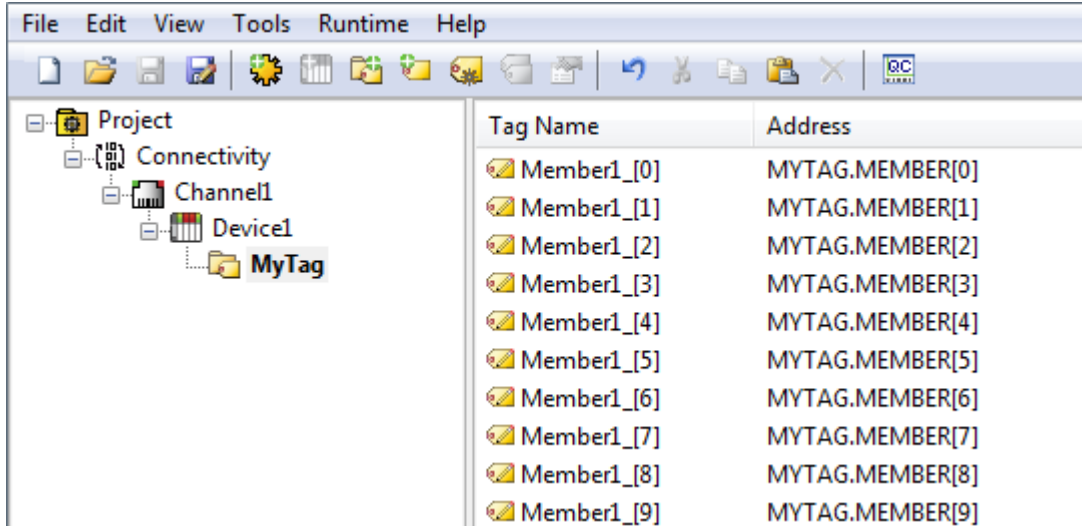

**Complex Example**

Logix tag is defined with address "Local:1:O.Slot[9].Data". This would be represented in the groups "Local:1:O" -> "Slot[9]". Within the last group would be the tag "Data".

The static reference to "Data" would be "Channel1.Device1.Local:1:O.Slot[9].Data". The dynamic reference would be "Channel1.Device1.Local:1:O.Slot[9].Data".

**Note:** I/O module tags cannot be directly imported in Offline mode. Since aliases can be imported, it is recommended that they be created for I/O module tags of interest in RSLogix5000.

**Controller-to-Server Name Conversions**

**Leading Underscores**

Leading underscores "\_" in tag or program names are replaced with "U\_". This is required because the server does not accept tag or group names beginning with an underscore.

**Long Names (OPC Server Version 4.64 and below)**

Under older OPC server versions, the Allen-Bradley ControlLogix Ethernet Driver was limited to 31 characters in group and tag names. Therefore, if a controller program or tag name exceeded 31 characters, it had to be clipped. OPC server Version 4.70 and above has a 256-character limit, so the rules do not apply. Names are clipped as follows:

**Non-Array**

1. Determine a 5-digit unique ID for this tag.
2. Given a tag name: ThisIsALongTagNameAndProbablyExceeds31
3. Clip tag at 31: ThisIsALongTagNameAndProbablyEx
4. Room is made for the unique ID: ThisIsALongTagNameAndProba#####
5. Insert this ID: ThisIsALongTagNameAndProba00000

**Array**

1. Determine a 5-digit unique ID for this array.
2. Given an array tag name: ThisIsALongTagNameAndProbablyExceeds31\_23\_45\_8
3. Clip tag at 31 while holding on to the element values: ThisIsALongTagNameAndPr\_23\_45\_8
4. Room is made for the unique ID: ThisIsALongTagName#####\_23\_45\_8
5. Insert this ID: ThisIsALongTagName00001\_23\_45\_8

Long program names are clipped in the same manner as long non-array tag names. For every tag or program name that is clipped, the unique ID is incremented. Array tag names (elements) of a clipped array name have the same unique ID. This provides for 100000 unique tag/program names.

● **Note:** If Limit Name Length is enabled, the rules apply even if the 256-character names are supported. For more information, refer to [Logix Database Settings](#).

## Preparing for Automatic Tag Database Generation

---

For information on using Automatic Tag Database Generation, follow the instructions below.

### Online

It is recommended that all communications to the Logix CPU of interest cease during the database creation process.

#### In RSLogix5000

Set the project OFFLINE.

#### In the server

1. Review the device properties of the device for which tags will be generated.
2. Within **Logix Database Settings** and select **Create from Device** for **Database Import Method**.
3. In **Logix Database Options**, make any desired changes and click **OK**.
4. In **Logix Database Filtering**, make any desired changes and click **OK**.
5. Select **Tag Generation** and, under Create, click the blue link to **Create tags**.

● **Note:** In **Logix Options**, set **Protocol Mode** to **Symbolic** and **Default Data Type** to **Default** so that the tags are imported with the data types used in the controller.

### Offline

The Allen-Bradley ControlLogix Ethernet Driver uses a file generated from RSLogix5000 called an L5K/L5X import/export file to generate the tag database.

#### In RSLogix5000

1. Open the project containing the tags to be ported over to the OPC server.
2. Click **File | Save As**.
3. Select **L5K/L5X Import/Export File** and specify a name. RSLogix will export the project's contents into this L5K/L5X file.

#### In the OPC Server

1. Open the device properties of the device for which tags will be generated.
2. Select **Logix Database Settings** and select **Create from Import File** for **Database Import Method**.
3. Enter or browse for the location of the file previously created.
4. In **Logix Database Options**, make any desired changes and click **OK**.

5. In **Logix Database Filtering**, make any desired changes and click **OK**.
6. Select **Tag Generation** and, under Create, click the blue link to **Create tags**.

● **Note:** Imported pre-defined tag types are based on the latest version supported by the driver. For more information, refer to Firmware Versions.

## Performance Optimization

---

For more information about optimization of communication and application, select a link below.

[Optimizing Communications](#)

[Optimizing Application](#)

[Performance Statistics and Tuning](#)

[Performance Tuning Example](#)

## Optimizing Communications

---

As with any programmable controller, there are a variety of ways to enhance the performance and system communications.

### Protocol Mode

The Protocol Mode determines how Logix tag data is accessed from the controller. There are three types of protocol modes: Symbolic, Logical Non-Blocking and Logical Blocking. Descriptions are as follows:

- **Symbolic Mode:** Each client/server tag address is represented in the packet by its ASCII character name.
- **Logical Non-Blocking Mode:** Each client/server tag is represented by its logical memory address in the PLC.
- **Logical Blocking Mode:** The Logix tag is accessed as a single chunk of data. Each client/server tag (such as MYTIMER.ACC) has a corresponding Logix tag (MYTIMER). Many client/server tags can belong to the same Logix tag, as in the case of structures. On every read cycle, the Logix tag is read, its block is updated in the driver cache and all client/server tags are updated from this cache.

Logical Non-Blocking Mode is generally recommended because it is the most efficient mode for gathering and processing Logix tag data. Symbolic Mode is recommended for backward compatibility, whereas Logical Non-Blocking Mode is recommended for projects containing a small number of references to UDT and/or predefined structure Logix tags. Although Logical Blocking Mode can be efficient, it can also hurt performance if used incorrectly. For more information on each mode's benefits and detriments, refer to [Choosing a Protocol Mode](#).

### Tag Division Tips

Users should designate one or more devices for Logical Blocking purposes and one or more devices for Logical Non-Blocking purposes. This improves performance because different tags in a project are often better suited for different modes. When utilizing tag division, users should do the following:

1. Assign server tags referencing Atomic Logix tags (array or non-array) to the Logical Non-Blocking device.
2. Assign server tags referencing a Structure Logix tag composed of one-third\* or less of the Structure tag to the Logical Non-Blocking device(s). For example, if there are 55\*\* or less member tags referencing a PID\_ENHANCED Logix tag, all these tags should be assigned to the Logical Non-Blocking device.
3. Assign server tags referencing a Structure Logix tag composed of one-third\* or more of the Structure tag to the Logical Blocking device(s). For example, if there are more than 55\*\* member tags referencing a PID\_ENHANCED Logix tag, all of those tags should be assigned to the Logical Blocking device.

\*One-third is not an exact limit, but rather a figure that has held true in a number of studies.

\*\*A PID\_ENHANCED structure has 165 tags, so one-third equals 55 tags.

## Connection Size

Increasing the Connection Size allows more read/write requests per data packet, which provides greater throughput. Although it also increases the CPU load and response turnaround time, it significantly improves performance. The Connection Size property may be modified in the ControlLogix 5500 and CompactLogix 5300 device models only. For more information, refer to [Logix Communications Parameters](#).

## UDT Substructure Aliasing

If a UDT contains large substructures and one-third or more of the substructure members are referenced in the client, refer to the following instructions to optimize reads for the substructure.

1. Create an alias of the substructure in RSLogix 5000. Then, assign server tags referencing the rest of the UDT substructure to a Logical Blocking device.
2. Next, assign the server tags referencing the rest of the UDT (but not the substructure) to a Logical Non-Blocking device.

## System Overhead Time Slice

The System Overhead Time Slice (SOTS) is the percentage of time allocated to perform communication tasks (such as OPC driver communications) that is set in RSLogix 5000. 100% SOTS is the percentage of time for controller tasks (such as ladder logic). The default SOTS is 10%. In every 10 ms program scan that occurs, the controller spends 1 ms processing driver requests (if the controller has a continuous task). The value of SOTS defines the task's priority. If controller tasks are a high priority, the SOTS should be set below 30%. If the communication tasks are high priority, the SOTS should be set at or above 30%. For the best balance of communications performance and CPU utilization, set the SOTS to 10% to 40%.

## Multi-Request Packets

The Allen-Bradley ControlLogix Ethernet Driver has been designed to optimize reads and writes. For non-array, non-string tags (which only request one element), requests are blocked into a single transaction. This provides drastic improvement in performance over single tag transactions. The only limitation is the number of data bytes that can fit in a single transaction.

**Important:** In Symbolic Mode, each tag's ASCII string value is inserted into the request packet until no more tag requests fit. For optimum performance, users should keep the tag names' size to a minimum. The smaller the tag name, the more tags that fit in a single transaction and the fewer transactions needed to process all tags.

## Array Elements Blocked (Symbolic and Logical Non-Blocking Modes Only)

To optimize the reading of atomic array elements, read a block of the array in a single request instead of individually. The more elements read in a block, the greater the performance. Since transaction overhead and processing consumes the most time, do as few transactions as possible while scanning as many desired tags as possible. This is the essence of array element blocking.

Block sizes are specified as an element count. A block size of 120 elements means that a maximum of 120 array elements are read in one request. The maximum block size is 3840 elements. Boolean arrays are treated differently: in protocol, a Boolean array is a 32-bit array. Thus, requesting element 0 is requesting bits 0 through 31. To maintain consistency in discussion, a Boolean array element is considered a single bit. In summary, the maximum number of array elements (based on block size of 3840) that can be requested is as follows: 122880 BOOL, 3840 SINT, 3840 INT, 3840 DINT, 3840 REAL, 3840 LINT, 3840 UINT, 3840 USINT, 3840 ULINT, 3840 LREAL, 3840 TIME32, 3840 TIME, and 3840 LTIME.

As discussed in [Logix Communication Parameters](#), the block size is adjustable and should be chosen based on the project at hand. For example, if array elements 0-26 and element 3839 are tags to be read, then using a block size of 3840 is overly large and detrimental to the driver's performance. This is because all elements between 0 and 3839 are read on each request, even though only 28 of those elements are of importance. In this case, a block size of 30 is more appropriate. Elements 0-26 would be serviced in one request and element 3839 would be serviced on the next.

## Optimizing Strings

In the Logical Addressing modes, a write to STRING.DATA also writes to STRING.LEN with the proper length value.

## Terminate String Data at LEN

In this driver, string tags are structures with separate character data and length components. As such, the driver automatically reads a string tag in two transactions: one in Logical Protocol Mode for the string character data (DATA) and one in Symbolic Mode for the string length (LEN). When the Terminate String Data at LEN option is disabled, a single transaction is made to read the string character data. In this case, the Symbolic Mode read for string length is bypassed. In a project with many string tags, this can significantly reduce the time required to read all tags.

• For more information on the *Terminate String Data at LEN* option, refer to [Logix Options](#).

## Optimizing the Application

The Allen-Bradley ControlLogix Ethernet Driver has been designed to provide the best performance with the least amount of impact on the system's overall performance. While the Allen-Bradley ControlLogix Ethernet Driver is fast, there are a couple of guidelines that can be used to optimize the application and gain maximum performance.

The server refers to communications protocols, like Allen-Bradley ControlLogix Ethernet, as a channel. Each channel defined in the application represents a separate path of execution in the server. Once a channel has been defined, a series of devices must then be defined under that channel. Each of these devices represents a single Allen-Bradley Logix CPU from which data is collected. While this approach to defining the application provides a high level of performance, it doesn't take full advantage of the Allen-Bradley ControlLogix Ethernet Driver or the network. An example of how the application may appear when configured using a single channel is shown below.

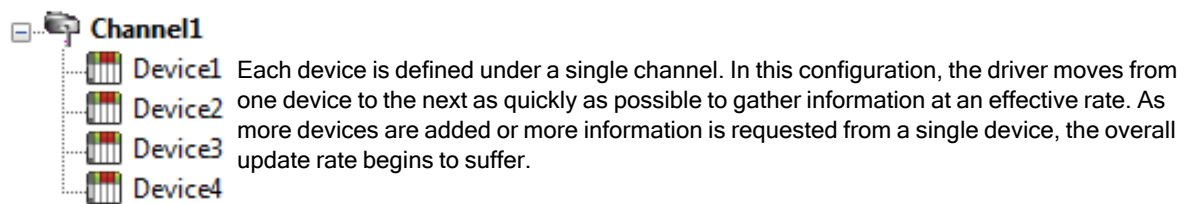

Each device is defined under a single channel. In this configuration, the driver moves from one device to the next as quickly as possible to gather information at an effective rate. As more devices are added or more information is requested from a single device, the overall update rate begins to suffer.

If the driver could only define a single channel, the above would be the only option available; however, the driver can define up to 1024 channels. Using multiple channels distributes the data collection workload by simultaneously issuing multiple requests to the network. An example of how the same application may appear when configured using multiple channels to improve performance is shown below.

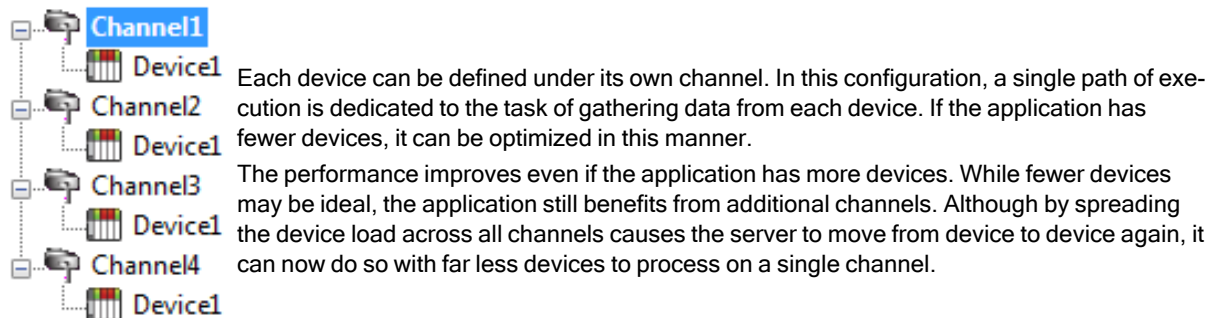

Each device can be defined under its own channel. In this configuration, a single path of execution is dedicated to the task of gathering data from each device. If the application has fewer devices, it can be optimized in this manner.

The performance improves even if the application has more devices. While fewer devices may be ideal, the application still benefits from additional channels. Although by spreading the device load across all channels causes the server to move from device to device again, it can now do so with far less devices to process on a single channel.

• See Also: [Performance Tuning Example](#), [Optimizing Communications](#), and [Performance Statistics and Tuning](#)

## Performance Statistics and Tuning

The Performance Statistics feature provides benchmarks and statistics about the application's performance. Because Performance Statistics is an additional layer of processing, it can affect the server's performance. As such, the default is off. To enable the Performance Statistics feature, access Device Properties and set **Logix Options** to enable **Enable Performance Statistics**.

### Types of Performance Statistics

Performance Statistics provide meaningful numerical results across three scopes: device, channel, and driver. Descriptions of the types are as follows:

- **Device:** These statistics provide the data access performance on a particular device.
- **Channel:** These statistics provide the average data access performance for all the devices under a given channel with Performance Statistics enabled.
- **Driver:** These statistics provide the average data access performance for all devices using the Allen-Bradley ControlLogix Ethernet Driver with Performance Statistics enabled.

### Choosing a Statistic Type

The type of statistics needed depends on the application. In general, driver statistics provide a true measure of the application's performance, whereas channel and device statistics are most relevant while tuning the application. For example, will moving 10 certain tags from Device A to Device B increase the performance of Device A? Will moving Device A from Channel 1 to Channel 2 increase the performance of Channel 1? These questions are good examples of situations when device and channel statistics should be used.

## Locating Statistics

Server statistics are output to the server's Event Log on shutdown. To view the results, shut down the server and restart it.

## Differences Between Server Statistics and Performance Statistics

Performance Statistics provide the makeup of the types of reads performed (such as symbolic vs. symbol instance vs. physical, or device reads vs. cache reads) whereas server statistics provide a general read count value.

## Tuning the Application for Increased Performance

• For information on increasing device and channel statistic results, refer to the instructions below. For more information, refer to [Optimizing Communications](#).

- Server tags referencing Atomic Logix tags (array or non-array) should be assigned to Logical Non-Blocking devices.
- Server tags referencing a Structure Logix tag composed of one-third or less of the Structure tag should be assigned to Logical Non-Blocking devices.
- Server tags referencing a Structure Logix tag composed of one-third or more of the Structure tag should be assigned to Logical Blocking devices.
- If Symbolic Mode is used, Logix names should be kept to a minimum length.
- Logix arrays should be used as often as possible.
- Only the necessary amount of System Overhead Time Slice for Ladder Logic/FBD should be allocated to leave the rest for driver communications.
- For projects that read a large number of string tags in Logical Mode, disable the **Terminate String Data at LEN** option located under **Logix Options** in **Device Properties**.

• For information on increasing driver statistic results, refer to the instructions below. For more information, refer to [Optimizing Application](#).

- Devices should be spread across channels. More than one device should not be put on a channel unless necessary.
- Load should be spread evenly across devices. A single device should not be overloaded unless necessary.
- The same Logix tag should not be referenced across different devices.

• **Note:** Although these general rules can help optimize performance, it ultimately depends on the application. The scan rate can obscure results: if tag requests are light, read and write transactions can complete before the next request comes in. In this case, Logical Blocking and Logical Non-Blocking will have the same Performance Statistics results. If tag requests are high (many tags or high scan rates), transaction completion time may take longer. This is when the strengths and weaknesses of Logical Blocking and Logical Non-Blocking become apparent. Performance Statistics can help tune the application for maximum performance. For an example, refer to [Performance Tuning Example](#).

## Performance Tuning Example

Statistics can be applied to any application. In the example below, the Quick Client is used in the performance tuning process. The idea is that all the tags used in the project are read at the same time at a fast scan rate. Although this is not realistic, it does provide an accurate benchmark to the project layout in the server (tags belonging to specific devices, devices belonging to specific channels, and so forth).

The statistics gathered are relative. Users should start with a server project layout, gather the statistics, and then tune. It is recommended that more than one trial be used to properly assess the results for a given layout. Once the most efficient layout is determined, the client application can be built with reassurance that the server is optimal.

• Performance results obtained using the Quick Client do not equate to performance results obtained using a client application: several factors produce discrepancies. Although performance tuning with the client application is more accurate than with the Quick Client, the tuning required not only affects the server project, but the client application

as well. It is recommended that the Quick Client be used to tune the application before the client application is developed.

**Note:** The tuning process described below assumes that all tags are being read at a fast scan rate. Writes hinder the performance.

1. In the controller project displayed below, there are the following:

- 2 Atomics
- 1 Atomic Array
- 1 UDT
- 1 UDT Array
- 1 Pre-Defined Type

**Note:** Overhead Time Slice (OTS) = 10%.

P	Tag Name	Alias For	Base Tag	Type
	InProcess			BOOL
<input type="checkbox"/>	+OverflowCounter			COUNTER
<input type="checkbox"/>	+ValveOpen			DINT[10]
<input type="checkbox"/>	+ProcessPID			PIDLoop
<input type="checkbox"/>	+FlowRates			ProcessVariable[2]
<input type="checkbox"/>	TankVolume			REAL
*				

2. After performing Automatic Tag Database Generation from this controller, the server produces the following project.

Tag Name	Address	Data Type
InProcess	INPROCESS	Boolean
TankVolume	TANKVOLUME	Float

**Note:** The "Global" tag group contains 130 tags.

3. To illustrate the benefits of tag division, this example does not reference all tags. More than one-third of the ProcessPID tags, less than one-third of the FlowRates tags, and all other tags are referenced. As such, the new tag count is 105.
4. Prepare the client for the test. To do so, launch the Quick Client from the server application by clicking on the QuickClient icon.
5. Once the project is loaded, remove all groups except those containing tags of interest. Statistics and System tags, for example, are not needed.

**Note:** For small projects, set the group **Update Rate** to 0-10 ms. For large projects, set the rate to 10-50 ms.

6. Select **Tools | Test Mode**.
7. Enable **Test 8. Activate items on start. Deactivate items on stop** and then set a test interval.

● **Note:** Since this project is fairly small, the interval has been set to 2 minutes. For larger projects, the interval should be increased to get a more accurate reading.

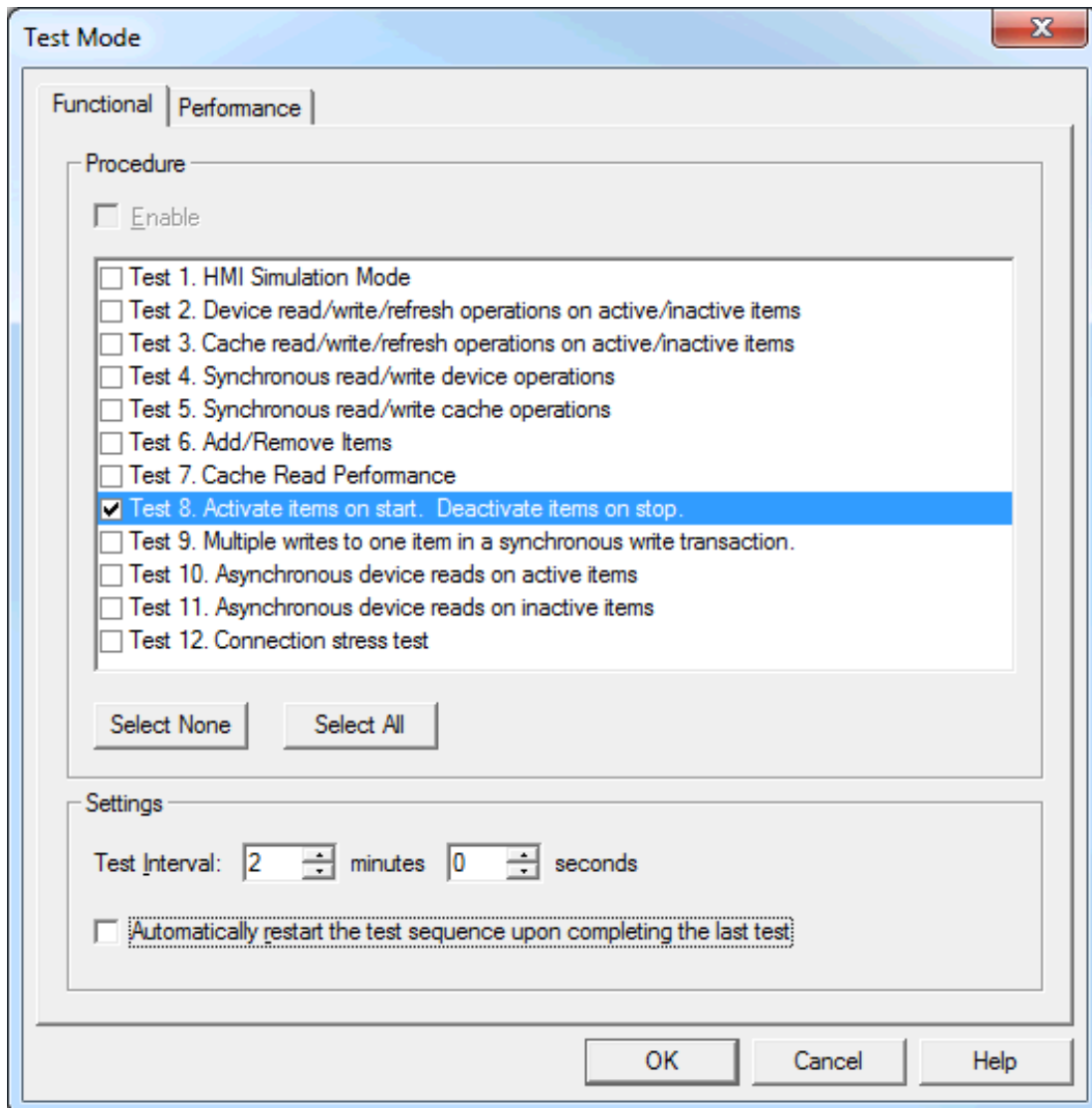

8. Return to **Tools | Test Mode** and disable test mode. All tags should be deactivated.
9. Disconnect the Quick Client so that time trials can begin.
10. Shutdown the server.
11. Launch the server and set the **Protocol Mode** to **Logical Blocking** under device properties.

12. Set **Performance Statistics** to Enable.

Property Groups	<input type="checkbox"/> <b>Protocol Options</b>	
General	Protocol Mode	<b>Logical Blocking</b>
Scan Mode	Synchronize After Online Edits	Yes
Timing	Synchronize After Offline Edits	Yes
Auto-Demotion	Terminate String Data at LEN	Enable
Tag Generation	<input type="checkbox"/> <b>Project Options</b>	
Logix Communicati...	Default Data Type	Default
<b>Logix Options</b>	Performance Statistics	<b>Enable</b> <input type="checkbox"/>
Logix Database Set...		
ENI DF1/DH+/CN ...		
Redundancy		

13. Connect to the server using the Quick Client. Select **Tools | Test Mode**. Enable Test Mode.

● **Note:** Data reading begins. When the test interval expires, all tags are deactivated and the driver ceases statistics gathering. The results can then be viewed.

14. Disconnect the Quick Client from the server and then shutdown the server.

15. Re-launch the server and search its Event Log for statistics. The image below displays the first trial utilizing Logical Blocking for the device.

```

DEVICE Channel1:Device1 STATISTICS
Physical Block Device Reads = 40932
Physical Block Cache Reads = 661734
Physical Non Block, Array Block Device Reads = 0
Physical Non Block, Array Block Cache Reads = 0
Physical Non Block Device Reads = 13644
Symbolic, Array Block Device Reads = 0
Symbolic, Array Block Cache Reads = 0
Symbolic Device Reads = 80
Total tags read = 716390, Elapsed Time = 119969 ms
DEVICE Channel1:Device1 PERFORMANCE: AvgTagReadPerSec = 5972.26

```

● **Note:** The image below displays the first trial utilizing Logical Blocking for the channel and driver.

```

DRIVER STATISTICS (ALL CHANNELS)
Physical Block Device Reads = 40932
Physical Block Cache Reads = 661734
Physical Non Block, Array Block Device Reads = 0
Physical Non Block, Array Block Cache Reads = 0
Physical Non Block Device Reads = 13644
Symbolic, Array Block Device Reads = 0
Symbolic, Array Block Cache Reads = 0
Symbolic Device Reads = 80
Total tags read = 716390, Elapsed Time = 119969 ms
DRIVER PERFORMANCE: AvgTagReadPerSec = 5972.26
Closing project C:\RDM\Support\ControlLogix Ethernet\CL_DEFAULT.opf
CHANNEL Channel1 STATISTICS
Physical Block Device Reads = 40932
Physical Block Cache Reads = 661734
Physical Non Block, Array Block Device Reads = 0
Physical Non Block, Array Block Cache Reads = 0
Physical Non Block Device Reads = 13644
Symbolic, Array Block Device Reads = 0
Symbolic, Array Block Cache Reads = 0
Symbolic Device Reads = 80
Total tags read = 716390, Elapsed Time = 119969 ms
CHANNEL Channel1 PERFORMANCE: AvgTagReadPerSec = 5972.26

```

● **Note:** This is the control set for comparisons.

16. In the server, set the **Protocol Mode** to **Logical Non-Blocking**.
17. Connect to the server using Quick Client. Select **Tools | Test Mode** and enable test mode.

● **Note:** Data reading begins. When the test interval expires, all tags are deactivated and the driver ceases statistics gathering. The results can then be viewed.

18. Disconnect the Quick Client from the server and then shutdown the server.
19. Re-launch the server and then search its Event Log for statistics. The image below displays the second trial utilizing Logical Non-Blocking for the device.

```

DEVICE Channel1:Device1 STATISTICS
Physical Block Device Reads = 0
Physical Block Cache Reads = 0
Physical Non Block, Array Block Device Reads = 8254
Physical Non Block, Array Block Cache Reads = 174419
Physical Non Block Device Reads = 261716
Symbolic, Array Block Device Reads = 2
Symbolic, Array Block Cache Reads = 0
Symbolic Device Reads = 63
Total tags read = 444454, Elapsed Time = 119969 ms
DEVICE Channel1:Device1 PERFORMANCE: AvgTagReadPerSec = 3705.23

```

● **Note:** The image below displays the second trial utilizing Logical Non-Blocking for the channel and driver.

```

DRIVER STATISTICS (ALL CHANNELS)
Physical Block Device Reads = 0
Physical Block Cache Reads = 0
Physical Non Block, Array Block Device Reads = 8254
Physical Non Block, Array Block Cache Reads = 174419
Physical Non Block Device Reads = 261716
Symbolic, Array Block Device Reads = 2
Symbolic, Array Block Cache Reads = 0
Symbolic Device Reads = 63
Total tags read = 444454, Elapsed Time = 119969 ms
DRIVER PERFORMANCE: AvgTagReadPerSec = 3705.23
Closing project C:\RDM\Support\ControlLogix Ethernet\CL_DEFAULT.opf
CHANNEL Channel1 STATISTICS
Physical Block Device Reads = 0
Physical Block Cache Reads = 0
Physical Non Block, Array Block Device Reads = 8254
Physical Non Block, Array Block Cache Reads = 174419
Physical Non Block Device Reads = 261716
Symbolic, Array Block Device Reads = 2
Symbolic, Array Block Cache Reads = 0
Symbolic Device Reads = 63
Total tags read = 444454, Elapsed Time = 119969 ms
CHANNEL Channel1 PERFORMANCE: AvgTagReadPerSec = 3705.23

```

20. From the server, set the **Protocol Mode** to **Symbolic** to see how the performance fared prior to Allen-Bradley ControlLogix Ethernet Driver version 4.6.0.xx.
21. Connect to the server using the Quick Client. Then, click **Tools | Test Mode** and enable test mode.
  - **Note:** Data reading begins. When the test interval expires, all tags are deactivated and the driver ceases statistics gathering. The results can then be viewed.
22. Disconnect the Quick Client from the server and then shutdown the server.
23. Re-launch the server and search its Event Log for statistics. The image below displays the third trial utilizing Symbolic for the device.

```

DEVICE Channel1:Device1 STATISTICS
Physical Block Device Reads = 0
Physical Block Cache Reads = 0
Physical Non Block, Array Block Device Reads = 0
Physical Non Block, Array Block Cache Reads = 0
Physical Non Block Device Reads = 0
Symbolic, Array Block Device Reads = 1744
Symbolic, Array Block Cache Reads = 36613
Symbolic Device Reads = 54985
Total tags read = 93342, Elapsed Time = 120063 ms
DEVICE Channel1:Device1 PERFORMANCE: AvgTagReadPerSec = 777.442

```

The image below displays the third trial utilizing Symbolic for the channel and driver.

```

DRIVER STATISTICS (ALL CHANNELS)
Physical Block Device Reads = 0
Physical Block Cache Reads = 0
Physical Non Block, Array Block Device Reads = 0
Physical Non Block, Array Block Cache Reads = 0
Physical Non Block Device Reads = 0
Symbolic, Array Block Device Reads = 1744
Symbolic, Array Block Cache Reads = 36613
Symbolic Device Reads = 54985
Total tags read = 93342, Elapsed Time = 120063 ms
DRIVER PERFORMANCE: AvgTagReadPerSec = 777.442
Closing project C:\RDM\Support\ControlLogix Ethernet\CL_DEFAULT.opf
CHANNEL Channel1 STATISTICS
Physical Block Device Reads = 0
Physical Block Cache Reads = 0
Physical Non Block, Array Block Device Reads = 0
Physical Non Block, Array Block Cache Reads = 0
Physical Non Block Device Reads = 0
Symbolic, Array Block Device Reads = 1744
Symbolic, Array Block Cache Reads = 36613
Symbolic Device Reads = 54985
Total tags read = 93342, Elapsed Time = 120063 ms
CHANNEL Channel1 PERFORMANCE: AvgTagReadPerSec = 777.442

```

● **Note:** It appears that Logical Blocking is most optimal for the given application.

### Optimizing Channel Communications

Channel communications can be optimized by moving tags for Logical Blocking in one device and tags for Logical Non-Blocking in another. This is called tag division.

#### Logical Blocking (Device 1)

ProcessPID  
OverflowCounter

#### Logical Non-Blocking (Device 2)

FlowRate  
ValveOpen  
InProcess  
Tank Volume

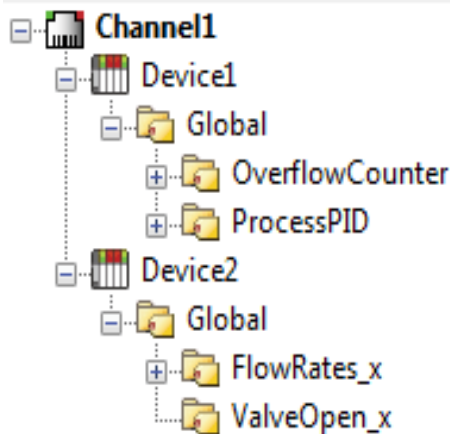

1. Repeat Steps 4 through 15. In Step 11, make sure that Device 1 is Logical Blocking and Device 2 is Logical Non-Blocking.
2. Launch the server and search the server Event Log for statistics. The image below displays the fourth trial utilizing tag division for the device.

```
DEVICE Channel1:Device1 STATISTICS
Physical Block Device Reads = 13866
Physical Block Cache Reads = 610104
Physical Non Block, Array Block Device Reads = 0
Physical Non Block, Array Block Cache Reads = 0
Physical Non Block Device Reads = 6933
Symbolic, Array Block Device Reads = 0
Symbolic, Array Block Cache Reads = 0
Symbolic Device Reads = 76
Total tags read = 630979, Elapsed Time = 119782 ms
DEVICE Channel1:Device1 PERFORMANCE: AvgTagReadPerSec = 5268.43
DEVICE Channel1:Device2 STATISTICS
Physical Block Device Reads = 0
Physical Block Cache Reads = 0
Physical Non Block, Array Block Device Reads = 6933
Physical Non Block, Array Block Cache Reads = 69375
Physical Non Block Device Reads = 27732
Symbolic, Array Block Device Reads = 0
Symbolic, Array Block Cache Reads = 0
Symbolic Device Reads = 4
Total tags read = 104044, Elapsed Time = 119969 ms
DEVICE Channel1:Device2 PERFORMANCE: AvgTagReadPerSec = 867.373
```

● **Note:** The image below displays the fourth trial utilizing tag division for the channel and driver.

```
DRIVER STATISTICS (ALL CHANNELS)
Physical Block Device Reads = 13866
Physical Block Cache Reads = 610104
Physical Non Block, Array Block Device Reads = 6933
Physical Non Block, Array Block Cache Reads = 69375
Physical Non Block Device Reads = 34665
Symbolic, Array Block Device Reads = 0
Symbolic, Array Block Cache Reads = 0
Symbolic Device Reads = 80
Total tags read = 735023, Elapsed Time = 119969 ms
DRIVER PERFORMANCE: AvgTagReadPerSec = 6126.77
Closing project C:\RDM\Support\ControlLogix Ethernet\CL_DEFAULT.opf
CHANNEL Channel1 STATISTICS
Physical Block Device Reads = 13866
Physical Block Cache Reads = 610104
Physical Non Block, Array Block Device Reads = 6933
Physical Non Block, Array Block Cache Reads = 69375
Physical Non Block Device Reads = 34665
Symbolic, Array Block Device Reads = 0
Symbolic, Array Block Cache Reads = 0
Symbolic Device Reads = 80
Total tags read = 735023, Elapsed Time = 119969 ms
CHANNEL Channel1 PERFORMANCE: AvgTagReadPerSec = 6126.77
```

● **Note:** The individual device statistics do not look impressive because the two devices are running on separate statistic counters. The key to this test is that the channel and driver statistics are better (6126) than using one channel/one device with either Logical Blocking (5972) or Logical Non-Blocking (3705).

## Optimize Application

The application can be optimized by moving Device 1 to one channel and Device 2 to another.

### Logical Blocking (Channel1.Device 1)

ProcessPID  
OverflowCounter

### Logical Non-Blocking (Channel2.Device 2)

FlowRate  
ValveOpen  
InProcess  
Tank Volume

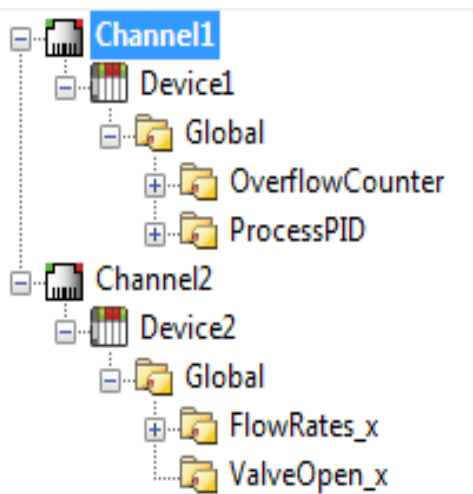

1. Repeat Steps 4 through 15. In Step 11, make sure Channel1.Device 1 is Logical Blocking and Channel2.Device 2 is Logical Non-Blocking.
2. Launch the server and search the server Event Log for statistics. The image below displays the fifth trial utilizing Logix tag coupled with multiple channels for Channel 1.Device1.

```
CHANNEL Channel1 STATISTICS
Physical Block Device Reads = 14542
Physical Block Cache Reads = 639848
Physical Non Block, Array Block Device Reads = 0
Physical Non Block, Array Block Cache Reads = 0
Physical Non Block Device Reads = 7271
Symbolic, Array Block Device Reads = 0
Symbolic, Array Block Cache Reads = 0
Symbolic Device Reads = 80
Total tags read = 661741, Elapsed Time = 119968 ms
CHANNEL Channel1 PERFORMANCE: AvgTagReadPerSec = 5517.4
DEVICE Channel1:Device1 STATISTICS
Physical Block Device Reads = 14542
Physical Block Cache Reads = 639848
Physical Non Block, Array Block Device Reads = 0
Physical Non Block, Array Block Cache Reads = 0
Physical Non Block Device Reads = 7271
Symbolic, Array Block Device Reads = 0
Symbolic, Array Block Cache Reads = 0
Symbolic Device Reads = 80
Total tags read = 661741, Elapsed Time = 119968 ms
DEVICE Channel1:Device1 PERFORMANCE: AvgTagReadPerSec = 5517.4
```

● **Note:** The image below displays the fourth trial utilizing Logix tag for Channel2.Device2.

```
CHANNEL Channel2 STATISTICS
Physical Block Device Reads = 0
Physical Block Cache Reads = 0
Physical Non Block, Array Block Device Reads = 7280
Physical Non Block, Array Block Cache Reads = 72800
Physical Non Block Device Reads = 29120
Symbolic, Array Block Device Reads = 1
Symbolic, Array Block Cache Reads = 0
Symbolic Device Reads = 4
Total tags read = 109205, Elapsed Time = 119968 ms
CHANNEL Channel2 PERFORMANCE: AvgTagReadPerSec = 910.52
DEVICE Channel2:Device2 STATISTICS
Physical Block Device Reads = 0
Physical Block Cache Reads = 0
Physical Non Block, Array Block Device Reads = 7280
Physical Non Block, Array Block Cache Reads = 72800
Physical Non Block Device Reads = 29120
Symbolic, Array Block Device Reads = 1
Symbolic, Array Block Cache Reads = 0
Symbolic Device Reads = 4
Total tags read = 109205, Elapsed Time = 119968 ms
DEVICE Channel2:Device2 PERFORMANCE: AvgTagReadPerSec = 910.52
```

● **Note:** The image below displays the fourth trial utilizing tag division for the driver.

```

DRIVER STATISTICS (ALL CHANNELS)
Physical Block Device Reads = 14542
Physical Block Cache Reads = 639848
Physical Non Block, Array Block Device Reads = 7280
Physical Non Block, Array Block Cache Reads = 72800
Physical Non Block Device Reads = 36391
Symbolic, Array Block Device Reads = 1
Symbolic, Array Block Cache Reads = 0
Symbolic Device Reads = 84
Total tags read = 770946, Elapsed Time = 119968 ms
DRIVER PERFORMANCE: AvgTagReadPerSec = 6426.26

```

## Results

Server Project Layout	Driver Performance (Reads / Second)	Improvement Over Symbolic
Single Channel / Single Device with Logical Blocking	5972	768%
Single Channel / Single Device with Logical Non-Blocking	3705	476%
Single Channel / Single Device with Symbolic	777	N/A
Single Channel / Multiple Devices with Tag Division	6126	788%
Multiple Channels / Multiple Devices with Tag Division	6426	827%

## Conclusions

The project began with a single channel and a single device, which is the default behavior for a single controller. All tags were imported from this controller to this channel.device. All three protocol modes were then tested to see which would provide the best performance. In this case, Logical Blocking Protocol was the best. The best protocol depends on the application at hand. When performance is crucial, it is worth performing Logical Blocking and Logical Non-Blocking trials to determine which is the best protocol mode for the application. Symbolic protocol is not necessary because it never meets the performance caliber of either of the other protocol modes. It is shown here for the sake of the example.

Measures were taken to optimize communications using the tips outlined in [Optimizing Communications](#). Most notably, tag division was used to place the Logical Blocking type tags in a device assigned Logical Blocking and the Logical Non-Blocking type tags in a device assigned Logical Non-Blocking. Furthermore, both devices resided on the same channel. The results show an improvement over using Logical Blocking on a single device. This is because some tags lend themselves better to one protocol mode over another. For example, reading an entire COUNTER benefits from Logical Blocking over Logical Non-Blocking since it's much faster reading the COUNTER as a block than as individual members.

Measures were also taken to optimize the application by placing devices on their own channel. Using the devices created in the previous trial, a Logical Blocking device was placed on one channel and a Logical Non-Blocking device on another. The results show improvement over the single channel / multiple devices scenario from the previous trial. This reinforces the idea that performance is improved by having as few devices per channel and as many channels as necessary.

**Tip:** When multiple devices are connected to the same PLC, different outcomes have been observed when using the L8 processor versus the L7 processor, potentially influenced by the firmware version in use. Testing various setups is advisable to identify the configuration that best suits your specific devices and firmware. In some scenarios, grouping all devices connected to the same PLC under a single channel may offer improved performance.

After using these optimization methods, the project has a significant performance increase (especially in older versions). The performance increase is more apparent with larger projects.

## Data Types Description

Data Types	Description
Boolean	Single bit
Byte	Unsigned 8-bit value
Char	Signed 8-bit value
Word	Unsigned 16-bit value
Short	Signed 16-bit value
DWord	Unsigned 32-bit value
Long	Signed 32-bit value
BCD	Two byte packed BCD, four decimal digits
LBCD	Four byte packed BCD, eight decimal digits
Float	32-bit IEEE floating point
Double	64-bit IEEE floating point
Date	64-bit Date/Time
String	Null-terminated character array

● For a description of Logix platform-specific data types, refer to [Logix Advanced Addressing](#).

● For specifics about Boolean arrays in firmware V30, visit the PTC website, log in to eSupport, and search for article cs332995.

## Default Data Type Conditions

Client / server tags are assigned the default data type when any of the following conditions occur:

1. A dynamic tag is created in the client with Native as its assigned data type.
2. A static tag is created in the server with Default as its assigned data type.
3. In offline automatic tag generation, when an unknown data type is encountered in the L5K/L5X file for UDT members and alias tags.
4. In offline automatic tag generation, when an alias of the following type is encountered in the L5K/L5X:
  - a. Alias of an alias.
  - b. Alias of non bit-within-Word/DWord I/O module tag. For example, if tag "AliasTag" references I/O module tag "Local:5:C.ProgToFaultEn" @ BOOL, the data type for "AliasTag" cannot be resolved, so this default type is assigned to it. On the other hand, if "AliasTag" references I/O module tag "Local:5:C.Ch0Config.RangeType.0" @ BOOL, the data type can be resolved because of the . (dot) BIT that defines it as a bit-within-Word/DWord. Aliases of bit-within-Word/DWord I/O module tags are automatically assigned the Boolean data type.

### ● Notes:

1. If Default is selected, the driver retrieves the Logix tag's data type from the controller when a client is accessing a tag dynamically and does not explicitly assign a data type to the item. For example, a tag exists in the controller that is called "MyTag" with a data type of REAL. The corresponding client item is specified as "Channel1.Device1.MyTag" with no data type assigned. With Default selected as the default data type in the server, the driver reads "MyTag" from the controller and determine that it is a REAL in the response, providing the client a data type of Float.
2. Since the majority of I/O module tags are not bit-within-Word/DWord tags, it is advised that the default type be set to the majority data type as observed in the .ACD project. For example, if 75% of alias I/O module tags are INT tags, set the default type to INT.

## Address Descriptions

Address specifications vary depending on the model in use. For the model of interest's address information, refer to the table below.

Model	Output	Input	Status	Binary	Timer	Counter	Control	Integer	Float	ASCII	String	BCD	Long	PID	Message	Block Transfer	Function
MicroLogix	X	X	X	X	X	X	X	X	X	X	X	X		X	X		
PLC5	X	X	X	X	X	X	X	X	X	X	X	X		X	X	X	
SLC5/05	X	X	X	X	X	X	X	X	X	X	X						

**See Also:**

[Logix Addressing](#)

[MicroLogix Addressing](#)

[PLC-5 Series Addressing](#)

[SLC 500 Modular I/O Addressing](#)

Protocol Class	Models	Help Link
Logix-Ethernet	ControlLogix 5500 Ethernet, CompactLogix 5300 Ethernet, FlexLogix 5400 Ethernet, SoftLogix 5800	<a href="#">Logix Addressing</a>
DH+ Gateway	DH+ Gateway: PLC-5 DH+ Gateway: SLC 5/04	<a href="#">PLC-5 Series Addressing</a> <a href="#">SLC 500 Modular I/O Addressing</a>
ControlNet Gateway	ControlNet Gateway: PLC-5C	<a href="#">PLC-5 Series Addressing</a>
1761-NET-ENI	ENI: ControlLogix 5500 ENI: CompactLogix 5300 ENI: FlexLogix 5400 ENI: MicroLogix ENI: SLC 500 Fixed I/O ENI: SLC 500 Modular I/O ENI: PLC-5	<a href="#">Logix Addressing</a> <a href="#">MicroLogix Addressing</a> <a href="#">SLC 500 Fixed I/O Addressing</a> <a href="#">SLC 500 Modular I/O Addressing</a> <a href="#">PLC-5 Series Addressing</a>
MicroLogix 1100 Ethernet	MicroLogix 1100	<a href="#">MicroLogix Addressing</a>
MicroLogix 1400 Ethernet	MicroLogix 1400	<a href="#">MicroLogix Addressing</a>

**For more information on the controller's pre-defined data types, refer to the device documentation.**

---

## Logix Addressing

• For more information on these models' tag-based addressing and relationship to the Allen-Bradley ControlLogix Ethernet Driver, refer to [Logix Tag-Based Addressing](#).

### ControlLogix 5500 Addressing for Ethernet

ControlLogix is a member of the Logix family and part of Rockwell Automation's Integrated Architecture. This means it uses a tag or symbol-based addressing structure. Logix tags differ from conventional PLC data items in that the tag name itself is the address, not a physical or logical address.

### ControlLogix 5500 Addressing for ENI

ControlLogix is a member of the Logix family and part of Rockwell Automation's Integrated Architecture. This means it uses a tag or symbol-based addressing structure. Logix tags differ from conventional PLC data items in that the tag name itself is the address, not a physical or logical address.

### ControlLogix 5500 Addressing for Serial Gateway

ControlLogix is a member of the Logix family and part of Rockwell Automation's Integrated Architecture. This means it uses a tag or symbol-based addressing structure. Logix tags differ from conventional PLC data items in that the tag name itself is the address, not a physical or logical address.

### CompactLogix 5300 Addressing for Ethernet

CompactLogix is a member of the Logix family and part of Rockwell Automation's Integrated Architecture. This means it uses a tag or symbol-based addressing structure. Logix tags differ from conventional PLC data items in that the tag name itself is the address, not a physical or logical address.

### CompactLogix 5300 Addressing for ENI

CompactLogix is a member of the Logix family and part of Rockwell Automation's Integrated Architecture. This means it uses a tag or symbol-based addressing structure. Logix tags differ from conventional PLC data items in that the tag name itself is the address, not a physical or logical address.

### CompactLogix 5300 Addressing for Serial Gateway

CompactLogix is a member of the Logix family and part of Rockwell Automation's Integrated Architecture. This means it uses a tag or symbol-based addressing structure. Logix tags differ from conventional PLC data items in that the tag name itself is the address, not a physical or logical address.

### FlexLogix 5400 Addressing for Ethernet

FlexLogix is a member of the Logix family and part of Rockwell Automation's Integrated Architecture. This means it uses a tag or symbol-based addressing structure. Logix tags differ from conventional PLC data items in that the tag name itself is the address, not a physical or logical address.

### FlexLogix 5400 Addressing for ENI

FlexLogix is a member of the Logix family and part of Rockwell Automation's Integrated Architecture. This means it uses a tag or symbol-based addressing structure. Logix tags differ from conventional PLC data items in that the tag name itself is the address, not a physical or logical address.

### FlexLogix 5400 Addressing for Serial Gateway

FlexLogix is a member of the Logix family and part of Rockwell Automation's Integrated Architecture. This means it uses a tag or symbol-based addressing structure. Logix tags differ from conventional PLC data items in that the tag name itself is the address, not a physical or logical address.

### SoftLogix 5800 Addressing

SoftLogix is a member of the Logix family and part of Rockwell Automation's Integrated Architecture. This means it uses a tag or symbol-based addressing structure. Logix tags differ from conventional PLC data items in that the tag name itself is the address, not a physical or logical address.

### SoftLogix 5800 Addressing for Serial Gateway

SoftLogix is a member of the Logix family and part of Rockwell Automation's Integrated Architecture. This means it uses a tag or symbol-based addressing structure. Logix tags differ from conventional PLC data items in that the tag name itself is the address, not a physical or logical address.

## MicroLogix Addressing

---

### MicroLogix Addressing for EtherNet/IP Gateway

The actual number of addresses available depends on the model of the PLC. The ranges have been opened up to allow for maximum flexibility with future models. If the driver finds at Runtime that an address is not present in the device, it posts an error message and then removes the tag from its scan list. For more information on file-specific addressing, select a link from the list below.

[Output Files](#)

[Input Files](#)

[Status Files](#)

[Binary Files](#)

[Timer Files](#)

[Counter Files](#)

[Control Files](#)

[Integer Files](#)

[Float Files](#)

[ASCII Files](#)

[String Files](#)

[Long Files](#)

[MicroLogix PID Files](#)

[MicroLogix Message Files](#)

For information on function files, select a link from the list below.

[High-Speed Counter File \(HSC\)](#)

[Real-Time Clock File \(RTC\)](#)

[Channel 0 Communication Status File \(CS0\)](#)

[Channel 1 Communication Status File \(CS1\)](#)

[I/O Module Status File \(IOS\)](#)

### MicroLogix Addressing for ENI

The actual number of addresses available depends on the model of the PLC. The ranges have been opened up to allow for maximum flexibility with future models. If the driver finds at Runtime that an address is not present in the device, it posts an error message and then removes the tag from its scan list. For more information on file-specific addressing, select a link from the list below.

[Output Files](#)

[Input Files](#)

[Status Files](#)

[Binary Files](#)

[Timer Files](#)

[Counter Files](#)

[Control Files](#)

[Integer Files](#)

[Float Files](#)

[ASCII Files](#)

[String Files](#)

[Long Files](#)

[MicroLogix PID Files](#)

[MicroLogix Message Files](#)

For information on function files, select a link from the list below.

[High-Speed Counter File \(HSC\)](#)  
[Real-Time Clock File \(RTC\)](#)  
[Channel 0 Communication Status File \(CS0\)](#)  
[Channel 1 Communication Status File \(CS1\)](#)  
[I/O Module Status File \(IOS\)](#)

### MicroLogix 1100 Addressing

The actual number of addresses available depends on the model of the PLC. The ranges have been opened up to allow for maximum flexibility with future models. If the driver finds at Runtime that an address is not present in the device, it posts an error message and then removes the tag from its scan list. For more information on file-specific addressing, select a link from the list below.

[Output Files](#)  
[Input Files](#)  
[Status Files](#)  
[Binary Files](#)  
[Timer Files](#)  
[Counter Files](#)  
[Control Files](#)  
[Integer Files](#)  
[Float Files](#)  
[String Files](#)  
[Long Files](#)  
[MicroLogix PID Files](#)  
[MicroLogix Message Files](#)

For information on function files, select a link from the list below.

[High-Speed Counter File \(HSC\)](#)  
[Real-Time Clock File \(RTC\)](#)  
[Channel 0 Communication Status File \(CS0\)](#)  
[Channel 1 Communication Status File \(CS1\)](#)  
[I/O Module Status File \(IOS\)](#)

### MicroLogix 1400 Addressing

The actual number of addresses available depends on the model of the PLC. The ranges have been opened up to allow for maximum flexibility with future models. If the driver finds at Runtime that an address is not present in the device, it posts an error message and then removes the tag from its scan list. For more information on file-specific addressing, select a link from the list below.

[Output Files](#)  
[Input Files](#)  
[Status Files](#)  
[Binary Files](#)  
[Timer Files](#)  
[Counter Files](#)  
[Control Files](#)  
[Integer Files](#)  
[Float Files](#)  
[ASCII Files](#)  
[String Files](#)  
[Long Files](#)  
[MicroLogix PID Files](#)  
[MicroLogix Message Files](#)

For information on function files, select a link from the list below.

[High-Speed Counter File \(HSC\)](#)

[Real-Time Clock File \(RTC\)](#)

[Channel 0 Communication Status File \(CS0\)](#)

[Channel 1 Communication Status File \(CS1\)](#)

[I/O Module Status File \(IOS\)](#)

## SLC 500 Fixed I/O Addressing

---

### SLC 500 Fixed I/O Addressing for EtherNet/IP Gateway

For more information on file-specific addressing, select a link from the list below.

[Output Files](#)

[Input Files](#)

[Status Files](#)

[Binary Files](#)

[Timer Files](#)

[Counter Files](#)

[Control Files](#)

[Integer Files](#)

### SLC 500 Fixed I/O Addressing for ENI

For more information on file-specific addressing, select a link from the list below.

[Output Files](#)

[Input Files](#)

[Status Files](#)

[Binary Files](#)

[Timer Files](#)

[Counter Files](#)

[Control Files](#)

[Integer Files](#)

## SLC 500 Modular I/O Addressing

---

### SLC 500 Modular I/O Addressing for DH+

The actual number of addresses available depends on the model of the PLC. The ranges have been opened up to allow for maximum flexibility with future models. If the driver finds at Runtime that an address is not present in the device, it posts an error message and then removes the tag from its scan list. For more information on file-specific addressing, select a link from the list below.

[Output Files](#)

[Input Files](#)

[Status Files](#)

[Binary Files](#)

[Timer Files](#)

[Counter Files](#)

[Control Files](#)

[Integer Files](#)

[Float Files](#)

[ASCII Files](#)

[String Files](#)

### SLC 500 Modular I/O Addressing for EtherNet/IP Gateway

The actual number of addresses available depends on the model of the PLC. The ranges have been opened up to allow for maximum flexibility with future models. If the driver finds at Runtime that an address is not present in the device, it posts an error message and then removes the tag from its scan list. For more information on file-specific addressing, select a link from the list below.

[Output Files](#)

[Input Files](#)

[Status Files](#)

[Binary Files](#)

[Timer Files](#)

[Counter Files](#)

[Control Files](#)

[Integer Files](#)

[Float Files](#)

[ASCII Files](#)

[String Files](#)

### SLC 500 Modular I/O Addressing for ENI

The actual number of addresses available depends on the model of the PLC. The ranges have been opened up to allow for maximum flexibility with future models. If the driver finds at Runtime that an address is not present in the device, it posts an error message and then removes the tag from its scan list. For more information on file-specific addressing, select a link from the list below.

[Output Files](#)

[Input Files](#)

[Status Files](#)

[Binary Files](#)

[Timer Files](#)

[Counter Files](#)

[Control Files](#)

[Integer Files](#)

[Float Files](#)

[ASCII Files](#)

[String Files](#)

### PLC-5 Series Addressing

---

#### PLC-5 Series Addressing for ControlNet

For more information on file-specific addressing, select a link from the list below.

[Output Files](#)

[Input Files](#)

[Status Files](#)

[Binary Files](#)

[Timer Files](#)

[Counter Files](#)

[Control Files](#)

[Integer Files](#)

[Float Files](#)

[ASCII Files](#)

[String Files](#)

[BCD Files](#)

[PID Files](#)

[Message Files](#)  
[Block Transfer Files](#)

### PLC-5 Series Addressing for DH+

For more information on file-specific addressing, select a link from the list below.

[Output Files](#)  
[Input Files](#)  
[Status Files](#)  
[Binary Files](#)  
[Timer Files](#)  
[Counter Files](#)  
[Control Files](#)  
[Integer Files](#)  
[Float Files](#)  
[ASCII Files](#)  
[String Files](#)  
[BCD Files](#)  
[PID Files](#)  
[Message Files](#)  
[Block Transfer Files](#)

### PLC-5 Series Addressing for EtherNet/IP Gateway

For more information on file-specific addressing, select a link from the list below.

[Output Files](#)  
[Input Files](#)  
[Status Files](#)  
[Binary Files](#)  
[Timer Files](#)  
[Counter Files](#)  
[Control Files](#)  
[Integer Files](#)  
[Float Files](#)  
[ASCII Files](#)  
[String Files](#)  
[BCD Files](#)  
[PID Files](#)  
[Message Files](#)  
[Block Transfer Files](#)

### PLC-5 Series Addressing for ENI

For more information on file-specific addressing, select a link from the list below.

[Output Files](#)  
[Input Files](#)  
[Status Files](#)  
[Binary Files](#)  
[Timer Files](#)  
[Counter Files](#)  
[Control Files](#)  
[Integer Files](#)  
[Float Files](#)

[ASCII Files](#)  
[String Files](#)  
[BCD Files](#)  
[PID Files](#)  
[Message Files](#)  
[Block Transfer Files](#)

## Logix Tag-Based Addressing

Rockwell Automation's Integrated Architecture uses a tag or symbol-based addressing structure that is commonly referred to as Logix tags (or Native Tags). These tags differ from conventional PLC data items in that the tag name itself is the address, not a physical or logical address.

● **Note:** Throughout this help file, Logix tags are assumed to be global in nature unless specified otherwise.

The Allen-Bradley ControlLogix Ethernet Driver allows users to access the controller's atomic data types: BOOL, SINT, INT, DINT, LINT, REAL, LREAL, USINT, UINT, UDINT, ULINT, TIME32, TIME, and LTIME. Although some of the pre-defined types are structures, they are ultimately based on these atomic data types. Thus, all non-structure (atomic) members of a structure are accessible. For example, a TIMER cannot be assigned to a server tag but an atomic member of the TIMER can be assigned to the tag (such as TIMER.EN, TIMER.ACC, and so forth). If a structure member is a structure itself, both structures would have to be expanded to access an atomic member of the substructure. This is more common with user and module-defined types and is not found in any of the pre-defined types.

Atomic Data Type	Description		Range
BOOL	Single-bit value	VT_BOOL	0, 1
SINT	Signed 8-bit value	VT_UI1	-128 to 127
INT	Signed 16-bit value	VT_I2	-32,768 to 32,767
DINT	Signed 32-bit value	VT_I4	-2,147,483,648 to 2,147,483,647
LINT	Signed 64-bit value	VT_I8	-9,223,372,036,854,775,808 to 9,223,372,036,854,775,807
USINT	Unsigned 8-bit value	VT_UI1	0 to 255
UINT	Unsigned 16-bit value	VT_UI2	0 to 65535
UDINT	Unsigned 32-bit value	VT_UI4	0 to 4294967295
ULINT	Unsigned 64-bit value	VT_I8	0 to 18,446,744,073,709,551,615
REAL	32-bit IEEE floating point	VT_R4	±1.1754943508222875E-38 to ±3.4028234663852886E+38 (normalized) 0 ±1.4012984643248170E-45 to ±1.1754942106924411E-38 (denormalized)
LREAL	Signed 64-bit value	VT_R8	±2.2250738585072014E-308 to ±1.7976931348623157E+308 (normalized) 0, ±4.9406564584124654E-324 to ±2.2250738585072010E-308 (denormalized)
TIME32	Duration of time in micro-seconds as string	VT_BSTR	T32#-35m_47s_483ms_647us to T32#35m_47s_483ms_647us
	Duration of time in micro-seconds as signed 32-bit value	VT_I4	-2147483647 to 2147483647
TIME	Duration of time in micro-seconds as string	VT_BSTR	T#-106750d_12h_59m_59s_999ms_999us to T#106750d_12h_59m_59s_999ms_999us
	Duration of time in micro-	VT_I8	-9223246799999999 to 9223246799999999

Atomic Data Type	Description		Range
	seconds as signed 64-bit value		
LTIME	Duration of time in nano-seconds as string	VT_BSTR	LT#-106750d_12h_59m_59s_999ms_999us_999ns to LT#106750d_12h_59m_59s_999ms_999us_999ns
	Duration of time in nano-seconds as signed 64-bit value	VT_I8	-922324679999999999 to 922324679999999999

• **See Also:** [Logix Advanced Addressing](#)

### Client / Server Tag Address Rules

Logix tag names correspond to client / server tag addresses. Logix tag names (entered via RSLogix5000) follow the IEC 1131-3 identifier rules. Client / server tag addresses follow these same rules. They are as follows:

- Must begin with an alphabetic (A-Z, a-z) character or an underscore (\_).
- Can only contain alphanumeric characters and underscores.
- Can have as many as 40 characters.
- Cannot have consecutive underscores.
- Are not case sensitive.

### Client / Server Tag Name Rules

Tag name assignment in the server differs from address assignment in that names cannot begin with an underscore.

• **Note:** Logix tag names should be kept to a minimum in size for optimum performance. The smaller the name, the more requests that are able fit in a single transaction.

• Symbolic Mode users should keep the client / server tag addresses below 400 characters. For example, tagarray[1,2,4].somestruct.substruct\_array[3].basetag.[4] is 57 characters in length. Since a packet can only hold 500 data bytes, any overhead bytes that need to be added to the packet can greatly diminish the room available to the characters themselves. By keeping the address below 400, the tag request remains complete and valid.

• **See Also:** [Performance Optimizations](#)

## Address Formats

There are several ways to address a Logix tag statically in the server or dynamically from a client. The format used depends on the type and usage of the tag. For example, the bit format would be used when accessing a bit within a SINT-type tag. For information on address format and syntax, refer to the table below.

• **Note:** All formats except for Array and String are native to RSLogix5000. Therefore, when referencing an atomic data type, an RSLogix 5000 tag name can be copied and pasted into the server's tag address field and be valid.

Format	Syntax	Example	Notes
Standard	<logix tag name>	tag_1	Tag cannot be an array.
Array Element	<logix array tag name> [dim 1, dim2, dim 3]	tag_1 [2, 58, 547] tag_1 [0, 3]	Dimension range = 1 to 3   element range = 0 to 65535
Array w/o Offset*	<logix array tag name> {# columns} <logix array tag name> {# rows}{# columns}	tag_1 {8} tag_1 {2}{4}	Dimension range = 1 to 2   element range = 1 to 65535 The number of elements to read/write equals # of rows times # of columns. If no rows are specified, # of rows default to 1. The array begins at a zero offset (array index equals 0 for all dimensions).
Array w/ Offset*	<logix array element tag> [offset1,offset2]{#}	tag_1 [2, 3] {10}	The array begins at an offset specified by the dimensions in the array element tag. The array

Format	Syntax	Example	Notes
	columns} <logix array element tag> [offset1,offset2]{# rows}{# columns}	tag_1 [2, 3] 2} {5}	always covers the highest dimension. Tag_1 [2,3]{10} would produce an array of elements tag_1[2,3] -> tag_1[2,13]
Bit	<logix tag name>.bit <logix tag name>.[bit]	tag_1.0 tag_1.[0]	Bit range = 0 to 31 If tag is an array, it must be a BOOL array, otherwise tag cannot be an array.
String	<logix tag name>/<maximum string length>	tag_1.Data/4 Stringtag_1.Data/82 SINTarraytag_1/16	Length range = 1 to 65535 The maximum number of characters that can read/write to the string.

\*Since this format may request more than one element, the order in which array data is passed depends on the dimension of the Logix Array tag. For example, if rows times cols = 4 and the Controller tag is a 3X3 element array, then the elements that are being referenced are array\_tag [0,0], array\_tag [0,1], array\_tag [0,2], and array\_tag [1,0] in that exact order. The results would be different if the Controller tag were a 2X10 element array.

• For more information on how elements are referenced for 1, 2, and 3 dimensional arrays, refer to [Ordering of Array Data](#).

## Tag Scope

### Global Tags

Global tags are Logix tags that have global scope in the controller. Any program or task can access Global tags; however, the number of ways a Global tag can be referenced depends on its Logix data type and the address format being used.

### Program Tags

Program tags are identical to Global tags except that a Program tag's scope is local to the program in which it is defined. Program tags follow the same addressing rules and limitations as Global tags, but are prefixed with the following notation:

*Program:* <program name>.

For example, Logix tag "tag\_1" in program "prog\_1" would be addressed as "Program:prog\_1.tag\_1" in a client/server tag address.

### Structure Tag Addressing

Logix Structure tags (Global or Program) are tags with one or more member tags. Member tags can be atomic or structured in nature.

<structure name>. <atomic-type tag>

This implies that a substructure would be addressed as:

<structure name> . <substructure name> .<atomic-type tag>

Arrays of structures would be addressed as:

<structure array name> [dim1, dim2, dim3] . <atomic-type tag>

This implies that an array of substructures would be addressed as:

<structure name> . <substructure array name> [dim1, dim2, dim3] . <atomic-type tag>

• **Note:** The examples above are only a few of the addressing possibilities that involve structures and are displayed to provide an introduction to structure addressing. For more information, refer to Allen-Bradley or Rockwell documentation.

## Internal Tags

Internal tags are not visible in the server configuration, but can be browsed by the OPC client and found under the <Channel Name>.<Device Name> group. The following tags are only valid for the ControlLogix 5500 and CompactLogix 5300 device models.

Tag Name	Support	Data Type	Access
_CIPConnectionSizeRequested	The CIP connection size that was last requested.	Word	Read/Write*
_CIPConnectionSizeActual	The actual CIP connection size that is in use. Its value differs from _CIPConnectionSizeRequested if the value requested is not supported by the device.	Word	Read Only
_LogicalAddressUploadCount	Number of controller project uploads that have occurred since startup or reset. Write 0 to reset.	Word	Read/Write
_LogicalAddressUploadDuration	Amount of time it took to perform the last controller project upload. Tag will hold this value until the next upload occurs.	Double	Read Only
_LastEditDetectedTimestamp	Timestamp for when the last controller project edit (online or offline) was detected.	String	Read Only
_LastLogicalAddressUploadTimestamp	Timestamp for when the last controller project upload began.	String	Read Only

\*This tag is read only for ENI Logix models.

## Changing the CIP Connection Size

The \_CIPConnectionSizeRequested tag allows users to change the CIP connection size property in real time. Both the connection size property (located under [Logix Communication Parameters](#) in **Device Properties**) and the System tag are configurable while clients are connected. Changes are applied before the next read/write request is performed.

## Predefined Term Tags

The tags displayed in the table below can be used to obtain general processor information from a PLC running firmware version 13 or higher.

Tag Name	Description
#MODE	A description of the PLC's current key switch mode. Possible string values include Program, Run, Remote Program, Remote Run, and Remote Debug. Supported data types include string.
#PLCTYPE	An integer value that corresponds to the "ProdType" attribute specified in the PLC's EDS file. Supported data types include all but string.
#REVISION	Firmware revision displayed as "<major>.<minor>". Supported data types include string.
#PROCESSORNAME	The processor name that corresponds to the "ProdName" attribute specified in the PLC's EDS file. Supported data types include string.
#STATUS	Indicates the PLC's status. Possible values include OK (1) and Faulted (0). Supported data types include all but date.
#PRODUCTCODE	An integer value that corresponds to the "ProdCode" attribute specified in the PLC's EDS file. Supported data types include all but string.
#VENDORID	An integer value that corresponds to the "VendCode" attribute specified in the PLC's EDS file. Supported data types include all but string.

## Addressing Atomic Data Types

Below are suggested usages and addressing possibilities for a Logix data type given the address formats available. Examples are also given for reinforcement. Click on **Advanced** for advanced addressing possibilities for the given atomic data type.

● **Tip:** If multiple server data types are supported for an Atomic Data Type, the default used in [Automatic Tag Database Generation](#) is shown in **bold**.

● **Note:** Empty cells do not necessarily indicate a lack of support.

Atomic Data Type	Standard	Array Element	Array with or without Offset	Bit	String
<b>BOOL</b>					
Client / Server Data Type <b>Advanced</b>	Boolean	Boolean (BOOL 1 dimensional array)	Boolean Array (BOOL 1 dimensional array)		See <a href="#">Advanced Addressing BOOL</a>
Client / Server Tag Example	BOOLTAG	BOOLARR[0]	BOOLARR[0]{32}		
<b>SINT</b>					
Client / Server Data Type <b>Advanced</b>	Byte, Char	Byte, Char	Byte Array, Char Array (SINT 1/2/3 dimensional array)	Boolean (Bit w/i SINT)	String (SINT 1/2/3 dimensional array) See <a href="#">Advanced Addressing SINT</a>
Client / Server Tag Example	SINTTAG	SINTARR[0]	SINTARR[0]{4}	SINTTAG.0	SINTARR/4
<b>INT</b>					
Client / Server Data Type <b>Advanced</b>	Word, Short	Word, Short	Word Array, Short Array (INT 1/2/3 dimensional array)	Boolean (Bit w/i INT)	See <a href="#">Advanced Addressing INT</a>
Client / Server Tag Example	INTTAG	INTARR[0]	INTARR[0]{4}	INTTAG.0	
<b>DINT</b>					
Client / Server Data Type <b>Advanced</b>	DWord, Long	DWord, Long	DWord Array, Long Array	Boolean (Bit w/i DINT)	See <a href="#">Advanced Addressing DINT</a>
Client / Server Tag Example	DINTTAG	DINTARR[0]	DINTARR[0]{4}	DINTTAG.0	
<b>LINT</b>					
Client/Server Data Type <b>Advanced</b>	Double, Date	Double, Date	Double Array		See <a href="#">Advanced Addressing LINT</a>
Client/Server Tag Example	LINTTAG	LINTARR[0]	LINTARR[0]{4}		
<b>REAL</b>					
Client/Server Data Type <b>Advanced</b>	Float	Float	Float Array		See <a href="#">Advanced Addressing REAL</a>
Client/Server Tag Example	REALTAG	REALARR[0]	REALARR[0]{4}		
<b>USINT</b>					
Client/Server Data Type	Byte	Byte	Byte Array	Boolean (Bit w/i USINT)	See <a href="#">Advanced Addressing USINT</a>

Atomic Data Type	Standard	Array Element	Array with or without Offset	Bit	String
<a href="#">Advanced</a>					
Client/Server Data Type	USINTTAG	USINTTARR[0]	USINTTARR[0]{4}	USINTTAG.0	
<b>UINT</b>					
Client / Server Data Type <a href="#">Advanced</a>	Word, BCD	Word, BCD	Word Array, BCD Array	Boolean (Bit w/i UINT)	See <a href="#">Advanced Addressing UINT</a>
Client / Server Tag Example	UINTTAG	UINTARR[0]	UINTARR[0]{4}	UINTTAG.0	
<b>UDINT</b>					
Client / Server Data Type <a href="#">Advanced</a>	DWord, LBCD	DWord, LBCD	DWord Array, LBCD Array	Boolean	See <a href="#">Advanced Addressing UDINT</a>
Client / Server Tag Example	UDINTTAG	UDINTARR[0]	UDINTARR[0]{4}	UDINTAG.0	
<b>ULINT</b>					
Client / Server Data Type <a href="#">Advanced</a>	Double	Double	Double Array		See <a href="#">Advanced Addressing ULINT</a>
Client / Server Tag Example	ULINTTAG	ULINTARR[0]	ULINTARR[0]{4}		
<b>LREAL</b>					
Client / Server Data Type <a href="#">Advanced</a>	Double	Double	Double Array		See <a href="#">Advanced Addressing LREAL</a>
Client / Server Tag Example	LREALTAG	LREALARR[0]	LREALARR[0]{4}		
<b>TIME32</b>					
Client / Server Data Type <a href="#">Advanced</a>	<b>String</b> , Long	<b>String</b> , Long	Long Array		See <a href="#">Advanced Addressing TIME32</a>
Client/Server Tag Example	TIME32TAG	TIME32ARR[0]	TIME32ARR[0]{4}		
<b>TIME</b>					
Client / Server Data Type <a href="#">Advanced</a>	<b>String</b> , LLong	<b>String</b> , LLong	LLong Array		See <a href="#">Advanced Addressing TIME</a>
Client / Server Tag Example	TIMETAG	TIMEARR[0]	TIMEARR[0]{4}		
<b>LTIME</b>					
Client / Server Data Type <a href="#">Advanced</a>	<b>String</b> , LLong	<b>String</b> , LLong	LLong Array		See <a href="#">Advanced Addressing LTIME</a>
Client / Server Tag Example	LTIMETAG	LTIMEARR[0]	LTIMEARR[0]{4}		

## Addressing Structure Data Types

Only the atomic structure members can be addressed at the structure level. For more information, refer to the examples below.

### Logix Tag

MyTimer @ TIMER

### Client/Server Tag

1. Invalid

TimerTag address = MyTimer

TimerTag data type = ??

2. Valid

TimerTag address = MyTimer.ACC

TimerTag data type = DWord

## Addressing STRING Data Type

STRING is a pre-defined Logix data type whose structure contains two members: DATA and LEN. DATA is an array of SINTs and stores the characters of the STRING. LEN is a DINT and represents the number of characters in DATA to display to a client.

● **Note:** String arrays are not supported.

Because LEN and DATA are atomic members, they must be referenced independently from a client/server. The syntax is as shown below.

Description	Syntax	Example
STRING Value	DATA/<Maximum STRING length >	MYSTRING.DATA/82
Actual STRING length	LEN	MYSTRING.LEN

### Reads

The STRING read from DATA is terminated by the following:

- a. The first null terminator encountered.
- b. The value in LEN if a) doesn't occur first.
- c. The <Maximum STRING length > if either a) or b) doesn't occur first.

### Example

MYSTRING.DATA contains "Hello World" in the PLC, but LEN is manually set to 5. A read of MYSTRING.DATA/82 displays "Hello". If LEN is set to 20, MYSTRING.DATA/82 displays "Hello World".

### Writes

When a STRING value is written to DATA, the driver also writes to LEN with the length of DATA written. If the write to LEN fails for any reason, the write operation to DATA is considered failed as well (despite the fact that the DATA write to the controller succeeded).

● **Note:** This behavior was designed specifically for Logix tags of type STRING or a custom derivative of it. The following precautions apply to users who wish to implement their own STRING in UDTs.

- If a UDT exists that has a DATA member referenced as a STRING and a LEN member referenced as a DINT, the write to LEN succeeds regardless of the intentions of LEN for the given UDT. Care must be taken when designing UDTs to avoid this possibility if LEN is not intended to be the length of DATA.
- If a UDT exists that has a DATA member referenced as a STRING but does not have a LEN member, the write to LEN fails silently without consequence to DATA.

### Example

MYSTRING.DATA/82 holds the value "Hello World." MYSTRING.LEN holds 11. If the value "Alarm Triggered" is written to MYSTRING.DATA/82, 15 is written to MYSTRING.LEN. If the write to MYSTRING.LEN fails, MYSTRING.LEN holds its previous value of 11 while MYSTRING.DATA/82 displays the first 11 characters ("Alarm Trigg"). If the write to MYSTRING.DATA/82 fails, neither tag is affected.

## Terminate String Data at LEN

In the logical addressing modes, reading STRING.DATA causes an automatic read of STRING.LEN in Symbolic Mode. This may be bypassed by disabling the Terminate String Data at LEN option. *For more information, refer to [Logix Options](#).*

## Ordering of Logix Array Data

---

### One-Dimensional Arrays - array [dim1]

One-dimensional array data is passed to and from the controller in ascending order.  
for (dim1 = 0; dim1 < dim1\_max; dim1++)

**Example:** 3 element array

```
array [0]
array [1]
array [2]
```

### Two-Dimensional Arrays - array [dim1, dim2]

Two-dimensional array data is passed to and from the controller in ascending order.  
for (dim1 = 0; dim1 < dim1\_max; dim1++)  
for (dim2 = 0; dim2 < dim2\_max; dim2++)

**Example:** 3X3 element array

```
array [0, 0]
array [0, 1]
array [0, 2]
array [1, 0]
array [1, 1]
array [1, 2]
array [2, 0]
array [2, 1]
array [2, 2]
```

### Three-Dimensional Arrays - array [dim1, dim2, dim3]

Three-dimensional array data is passed to and from the controller in ascending order.  
for (dim1 = 0; dim1 < dim1\_max; dim1++)  
for (dim2 = 0; dim2 < dim2\_max; dim2++)  
for (dim3 = 0; dim3 < dim3\_max; dim3++)

**Example:** 3X3x3 element array

```
array [0, 0, 0]
array [0, 0, 1]
array [0, 0, 2]
array [0, 1, 0]
array [0, 1, 1]
array [0, 1, 2]
array [0, 2, 0]
array [0, 2, 1]
array [0, 2, 2]
array [1, 0, 0]
array [1, 0, 1]
array [1, 0, 2]
array [1, 1, 0]
array [1, 1, 1]
array [1, 1, 2]
array [1, 2, 0]
array [1, 2, 1]
array [1, 2, 2]
array [2, 0, 0]
array [2, 0, 1]
array [2, 0, 2]
array [2, 1, 0]
array [2, 1, 1]
array [2, 1, 2]
array [2, 2, 0]
```

array [2, 2, 1]  
array [2, 2, 2]

## Logix Advanced Addressing

Advanced Addressing is available for the following atomic data types. Select a link from the list below for more information on a specific data type.

[BOOL](#)  
[SINT](#)  
[INT](#)  
[DINT](#)  
[LINT](#)  
[REAL](#)  
[USINT](#)  
[UINT](#)  
[UDINT](#)  
[ULINT](#)  
[LREAL](#)  
[TIME32](#)  
[TIME](#)  
[LTIME](#)

### Advanced Addressing: BOOL

Format	Supported Data Types	Notes
<a href="#">Standard</a>	Boolean, Byte, Char, Word, Short, BCD, DWord, Long, LBCD, Float*	None
	Boolean	The Controller tag must be a one-dimensional array.
<a href="#">Array w/o Offset</a>	Boolean Array	<ol style="list-style-type: none"> <li>The Controller tag must be a one-dimensional array.</li> <li>The number of elements must be a factor of 8.</li> </ol>
<a href="#">Array w/o Offset</a>	Byte Array, Char Array, Word Array, Short Array, BCD Array, DWord Array, Long Array, LBCD Array, Float Array*	Not supported.
<a href="#">Array w/ Offset</a>	Boolean Array	<ol style="list-style-type: none"> <li>The Controller tag must be a one-dimensional array.</li> <li>The offset must lie on 32-bit boundary.</li> <li>The number of elements must be a factor of 8.</li> </ol>
<a href="#">Bit</a>	Boolean	<ol style="list-style-type: none"> <li>The Controller tag must be a one-dimensional array.</li> <li>The range is limited from 0 to 31.</li> </ol>
<a href="#">String</a>	String	Not supported

\*The float value equals the face value of the Controller tag in float form (non-IEEE floating-point number).

### Examples

Examples [highlighted](#) signify common use cases.

**BOOL Controller Tag - booltag = true**

Server Tag Address	Format	Data Type	Notes
booltag	Standard	Boolean	Value = true
booltag	Standard	Byte	Value = 1
booltag	Standard	Word	Value = 1
booltag	Standard	DWord	Value = 1
booltag	Standard	Float	Value = 1.0
booltag [3]	Array Element	Boolean	Invalid: Tag not an array
booltag [3]	Array Element	Word	Invalid: Tag not an array
booltag {1}	Array w/o Offset	Word	Invalid: Not supported
booltag {1}	Array w/o Offset	Boolean	Invalid: Not supported
booltag [3] {32}	Array w/ Offset	Boolean	Invalid: Tag not an array
booltag . 3	Bit	Boolean	Invalid: Tag not an array
booltag / 1	String	String	Invalid: Not supported
booltag / 4	String	String	Invalid: Not supported

**BOOL Array Controller Tag - bitarraytag = [0,1,0,1]**

Server Tag Address	Format	Data Type	Notes
bitarraytag	Standard	Boolean	Invalid: Tag cannot be an array
bitarraytag	Standard	Byte	Invalid: Tag cannot be an array
bitarraytag	Standard	Word	Invalid: Tag cannot be an array
bitarraytag	Standard	DWord	Invalid: Tag cannot be an array
bitarraytag	Standard	Float	Invalid: Tag cannot be an array
bitarraytag [3]	Array Element	Boolean	Value = true
bitarraytag [3]	Array Element	Word	Invalid: Bad data type
bitarraytag {3}	Array w/o Offset	Word	Invalid: Tag cannot be an array
bitarraytag {1}	Array w/o Offset	Word	Invalid: Tag cannot be an array
bitarraytag {1}	Array w/o Offset	Boolean	Invalid: Array size must be a factor of 8
bitarraytag {32}	Array w/o Offset	Boolean	Value = [0,1,0,1,...]
bitarraytag [3] {32}	Array w/ Offset	Boolean	Offset must begin on 32-bit boundary
bitarraytag[0]{32}	Array w/ Offset	Boolean	Value = [0,1,0,1,...]
bitarraytag[32]{64}	Array w/ Offset	Boolean	Value = [...] <i>values not provided above</i>
bitarraytag . 3	Bit	Boolean	Value = true
bitarraytag / 1	String	String	Invalid: Not supported
bitarraytag / 4	String	String	Invalid: Not supported

**Advanced Addressing: SINT**

Format	Supported Data Types	Notes
<u>Standard</u>	Boolean*, Byte, Char, Word, Short, BCD, DWord, Long, LBCD, Float***	None
<u>Array Element</u>	Byte, Char, Word, Short, BCD, DWord, Long, LBCD, Float***	The Controller tag must be an array.
<u>Array w/o Offset</u>	Boolean Array	1. Use this case to have the bits within a SINT in array form. ● <b>Note:</b> This is not an array of SINTs in Boolean notation.

Format	Supported Data Types	Notes
		<ol style="list-style-type: none"> <li>Applies to bit-within-SINT only. Example: tag_1.0{8}.</li> <li>.bit + array size cannot exceed 8 bits. Example: tag_1.1{8} exceeds an SINT, tag_1.0{8} does not.</li> <li>Array size must be a multiple of eight (8).</li> </ol>
<u>Array w/o Offset</u>	Byte Array, Char Array, Word Array, Short Array, BCD Array**, DWord Array, Long Array, LBCD Array**, Float Array**, ***	If accessing more than a single element, the Controller tag must be an array.
<u>Array w/ Offset</u>	Byte Array, Char Array, Word Array, Short Array, BCD Array**, DWord Array, Long Array, LBCD Array**, Float Array**, ***	The Controller tag must be an array.
<u>Bit</u>	Boolean	<ol style="list-style-type: none"> <li>The range is limited from 0 to 7.</li> <li>If the Controller tag is an array, the bit class reference must be prefixed by an array element class reference. Example: tag_1 [2,2,3].0.</li> </ol>
<u>String</u>	String	<ol style="list-style-type: none"> <li>If accessing a single element, the Controller tag need not be an array.                     <ul style="list-style-type: none"> <li><b>Note:</b> The value of the string is the ASCII equivalent of the SINT value. Example: SINT = 65 dec = "A".</li> </ul> </li> <li>If accessing more than a single element, the Controller tag must be an array. The value of the string is the null-terminated ASCII equivalent of all the SINTs in the string. 1 character in string = 1 SINT.</li> </ol>

\*non-zero values are clamped to true.

\*\*Each element of the array corresponds to an element in the SINT array. Arrays are not packed.

\*\*\* Float value equals the face value of Controller tag in float form (non-IEEE floating-point number).

### Examples

Examples **highlighted** signify common use cases.

#### SINT Controller Tag - sinttag = 122 (decimal)

Server Tag Address	Format	Data Type	Notes
sinttag	Standard	Boolean	Value = true
sinttag	Standard	Byte	Value = 122
sinttag	Standard	Word	Value = 122
sinttag	Standard	DWord	Value = 122
sinttag	Standard	Float	Value = 122.0
sinttag [3]	Array Element	Boolean	Invalid: Tag not an array. Also, Boolean is invalid.
sinttag [3]	Array Element	Byte	Invalid: Tag not an array
sinttag {3}	Array w/o Offset	Byte	Invalid: Tag not an array
sinttag {1}	Array w/o Offset	Byte	Value = [122]
sinttag {1}	Array w/o Offset	Boolean	Invalid: Bad data type

Server Tag Address	Format	Data Type	Notes
sinttag [3] {1}	Array w/ Offset	Byte	Invalid: Tag not an array
sinttag . 3	Bit	Boolean	Value = true
sinttag . 0 {8}	Array w/o Offset	Boolean	Value = [0,1,0,1,1,1,1,0] Bit value of 122
sinttag / 1	String	String	Value = "z"
sinttag / 4	String	String	Invalid: Tag not an array

#### SINT Array Controller Tag - sintarraytag [4,4] = [[83,73,78,84],[5,6,7,8],[9,10,11,12],[13,14,15,16]]

Server Tag Address	Format	Data Type	Notes
sintarraytag	Standard	Boolean	Invalid: Tag cannot be an array
sintarraytag	Standard	Byte	Invalid: Tag cannot be an array
sintarraytag	Standard	Word	Invalid: Tag cannot be an array
sintarraytag	Standard	DWord	Invalid: Tag cannot be an array
sintarraytag	Standard	Float	Invalid: Tag cannot be an array
sintarraytag [3]	Array Element	Byte	Invalid: Server tag missing dimension 2 address
sintarraytag [1,3]	Array Element	Boolean	Invalid: Boolean not allowed for array elements
sintarraytag [1,3]	Array Element	Byte	Value = 8
sintarraytag {10}	Array w/o Offset	Byte	Value = [83,73,78,84,5,6,7,8,9,10]
sintarraytag {2} {5}	Array w/o Offset	Word	Value = [83,73,78,84,5] [6,7,8,9,10]
sintarraytag {1}	Array w/o Offset	Byte	Value = 83
sintarraytag {1}	Array w/o Offset	Boolean	Invalid: Bad data type
sintarraytag [1,3] {4}	Array w/ Offset	Byte	Value = [8,9,10,11]
sintarraytag . 3	Bit	Boolean	Invalid: Tag must reference atomic location
sintarraytag [1,3] . 3	Bit	Boolean	Value = 1
sintarraytag [1,3] . 0 {8}	Array w/o Offset	Boolean	Value = [0,0,0,1,0,0,0,0]
sintarraytag / 1	String	String	Value = "S"
sintarraytag / 4	String	String	Value = "SINT"

#### Advanced Addressing: INT

Format	Supported Data Types	Notes
<u>Standard</u>	Boolean*, Byte, Char**, Word, Short, BCD, DWord, Long, LBCD, Float****	None
<u>Array Element</u>	Byte, Char**, Word, Short, BCD, DWord, Long, LBCD, Float****	The Controller tag must be an array.
<u>Array w/o Offset</u>	Boolean Array	<ol style="list-style-type: none"> <li>Use this case to have the bits within an INT in array form. <ul style="list-style-type: none"> <li><b>Note:</b> This is not an array of INTs in Boolean notation.</li> </ul> </li> <li>Applies to bit-within-INT only. Example: tag_1.0{16}.</li> <li>.bit + array size cannot exceed 16 bits. Example: tag_1.1{16} exceeds</li> </ol>

Format	Supported Data Types	Notes
		<p>an INT, tag_1.0{16} does not.</p> <p>4. Array size must be a multiple of eight (8).</p>
<u>Array w/o Offset</u>	Byte Array, Char Array**, Word Array, Short Array, BCD Array, DWord Array, Long Array, LBCD Array***Float Array***, ****	If accessing more than a single element, the Controller tag must be an array.
<u>Array w/ Offset</u>	Byte Array, Char Array** Word Array, Short Array, BCD Array, DWord Array, Long Array, LBCD Array***, Float Array***, ****	The Controller tag must be an array.
<u>Bit</u>	Boolean	<p>1. The range is limited from 0 to 15.</p> <p>2. If the Controller tag is an array, the bit class reference must be prefixed by an array element class reference. Example: tag_1 [2,2,3].0.</p>
<u>String</u>	String	<p>1. If accessing a single element, the Controller tag need not be an array.</p> <p>● <b>Note:</b> The value of the string is the ASCII equivalent of the INT value (clamped to 255). Example: INT = 65 dec = "A".</p> <p>2. If accessing more than a single element, the Controller tag must be an array. The value of the string is the null-terminated ASCII equivalent of all the INTs (clamped to 255) in the string.</p> <p>1 character in string = 1 INT, clamped to 255</p> <p>INT strings are not packed. For greater efficiency, use SINT strings or the STRING structure instead.</p>

\*non-zero values are clamped to true.

\*\*Values exceeding 255 are clamped to 255.

\*\*\*Each element of the array corresponds to an element in the INT array. Arrays are not packed.

\*\*\*\*Float value equals the face value of Controller tag in float form (non-IEEE floating-point number).

## Examples

Examples highlighted signify common use cases.

### INT Controller Tag - inttag = 65534 (decimal)

Server Tag Address	Class	Data Type	Notes
inttag	Standard	Boolean	Value = true
inttag	Standard	Byte	Value = 255
inttag	Standard	Word	Value = 65534
inttag	Standard	DWord	Value = 65534
inttag	Standard	Float	Value = 65534.0
inttag [3]	Array Element	Boolean	Invalid: Tag not an array. Boolean is invalid.
inttag [3]	Array Element	Word	Invalid: Tag not an array.
inttag {3}	Array w/o Offset	Word	Invalid: Tag not an array.
inttag {1}	Array w/o Offset	Word	Value = [65534]

Server Tag Address	Class	Data Type	Notes
inttag {1}	Array w/o Offset	Boolean	Invalid: Bad data type.
inttag [3] {1}	Array w/ Offset	Word	Invalid: Tag not an array.
inttag . 3	Bit	Boolean	Value = true
inttag . 0 {16}	Array w/o Offset	Boolean	Value = [0,1,1,1,1,1,1,1,1,1,1,1,1,1,1,1] Bit value of 65534
inttag / 1	String	String	Value = unprintable character = 255 decimal.
inttag / 4	String	String	Invalid: Tag not an array.

#### INT Array Controller Tag - intarraytag [4,4] = [[73,78,84,255],[256,257,258,259],[9,10,11,12],[13,14,15,16]]

Server Tag Address	Class	Data Type	Notes
intarraytag	Standard	Boolean	Invalid: Tag cannot be an array.
intarraytag	Standard	Byte	Invalid: Tag cannot be an array.
intarraytag	Standard	Word	Invalid: Tag cannot be an array.
intarraytag	Standard	DWord	Invalid: Tag cannot be an array.
intarraytag	Standard	Float	Invalid: Tag cannot be an array.
intarraytag [3]	Array Element	Word	Invalid: Server tag missing dimension 2 address.
intarraytag [1,3]	Array Element	Boolean	Invalid: Boolean not allowed for array elements.
intarraytag [1,3]	Array Element	Word	Value = 259
intarraytag {10}	Array w/o Offset	Byte	Value = [73,78,84,255,255,255,255,255,9,10]
intarraytag {2} {5}	Array w/o Offset	Word	Value = [73,78,84,255,256] [257,258,259,9,10]
intarraytag {1}	Array w/o Offset	Word	Value = 73
intarraytag {1}	Array w/o Offset	Boolean	Invalid: Bad data type.
intarraytag [1,3] {4}	Array w/ Offset	Word	Value = [259,9,10,11]
intarraytag . 3	Bit	Boolean	Invalid: Tag must reference atomic location.
intarraytag [1,3] . 3	Bit	Boolean	Value = 0
intarraytag [1,3] . 0 {16}	Array w/o Offset	Boolean	Value = [1,1,0,0,0,0,0,0,1,0,0,0,0,0,0,0] Bit value for 259
intarraytag / 1	String	String	Value = "I"
intarraytag / 3	String	String	Value = "INT"

#### Advanced Addressing: DINT

Format	Supported Data Types	Notes
<b>Standard</b>	Boolean*, Byte, Char**, Word, Short, BCD***, DWord, Long, LBCD, Float ****	None
<b>Array Element</b>	Byte, Char**, Word, Short, BCD***, DWord, Long, LBCD, Float ****	The Controller tag must be an array.
<b>Array w/o Offset</b>	Boolean Array	1. Use this case to have the bits within a DINT in array form. ● <b>Note:</b> This is not an array of DINTs in Boolean notation.

Format	Supported Data Types	Notes
		<ol style="list-style-type: none"> <li>Applies to bit-within-DINT only. Example: tag_1.0{32}.</li> <li>.bit + array size cannot exceed 32 bits. Example: tag_1.1{32} exceeds a DINT, tag_1.0{32} does not.</li> <li>Array size must be a multiple of eight (8).</li> </ol>
<u>Array w/o Offset</u>	Byte Array, Char Array**, Word Array, Short Array, BCD Array***, DWord Array, Long Array, LBCD Array, Float Array ****	If accessing more than a single element, the Controller tag must be an array.
<u>Array w/ Offset</u>	Byte Array, Char Array**, Word Array, Short Array, BCD Array***, DWord Array, Long Array, LBCD Array, Float Array ****	The Controller tag must be an array.
<u>Bit</u>	Boolean	<ol style="list-style-type: none"> <li>The range is limited from 0 to 31.</li> <li>If Controller tag is an array, bit class reference must be prefixed by an array element class reference. Example: tag_1 [2,2,3].0.</li> </ol>
<u>String</u>	String	<ol style="list-style-type: none"> <li>If accessing a single element, the Controller tag need not be an array. <ul style="list-style-type: none"> <li><b>Note:</b> The value of the string is the ASCII equivalent of the DINT value (clamped to 255). Example: SINT = 65dec = "A".</li> </ul> </li> <li>If accessing more than a single element, the Controller tag must be an array. The value of the string is the null-terminated ASCII equivalent of all the DINTs (clamped to 255) in the string. 1 character in string = 1 DINT, clamped to 255. <ul style="list-style-type: none"> <li><b>Note:</b> DINT strings are not packed. For greater efficiency, use SINT strings or the STRING structure instead.</li> </ul> </li> </ol>

\*non-zero values are clamped to true.

\*\*Values exceeding 255 are clamped to 255.

\*\*\*Values exceeding 65535 are clamped to 65535.

\*\*\*\*Float value equals the face value of Controller tag in float form (non-IEEE floating-point number).

## Examples

Examples **highlighted** signify common use cases.

### DINT Controller Tag - dinttag = 70000 (decimal)

Server Tag Address	Format	Data Type	Notes
dinttag	Standard	Boolean	Value = true
dinttag	Standard	Byte	Value = 255
dinttag	Standard	Word	Value = 65535
dinttag	Standard	DWord	Value = 70000
dinttag	Standard	Float	Value = 70000.0
dinttag [3]	Array Element	Boolean	Invalid: Tag not an array. Boolean is invalid.

Server Tag Address	Format	Data Type	Notes
dinttag [3]	Array Element	DWord	Invalid: Tag not an array.
dinttag {3}	Array w/o Offset	DWord	Invalid: Tag not an array.
dinttag {1}	Array w/o Offset	DWord	Value = [70000]
dinttag {1}	Array w/o Offset	Boolean	Invalid: Bad data type
dinttag [3]{1}	Array w/ Offset	DWord	Invalid: Tag not an array.
dinttag . 3	Bit	Boolean	Value = false
dinttag . 0 {32}	Array w/o Offset	Boolean	Value = [0,0,0,0,1,1,1,0,1,0,0,0,1,0,0,0,1,0,...0] Bit value for 70000
dinttag / 1	String	String	Value = unprintable character = 255 decimal
dinttag / 4	String	String	Invalid: Tag not an array.

#### DINT Array Controller Tag - dintarraytag [4,4] = [[68,73,78,84],[256,257,258,259],[9,10,11,12],[13,14,15,16]]

Server Tag Address	Format	Data Type	Notes
dintarraytag	Standard	Boolean	Invalid: Tag cannot be an array.
dintarraytag	Standard	Byte	Invalid: Tag cannot be an array.
dintarraytag	Standard	Word	Invalid: Tag cannot be an array.
dintarraytag	Standard	DWord	Invalid: Tag cannot be an array.
dintarraytag	Standard	Float	Invalid: Tag cannot be an array.
dintarraytag [3]	Array Element	DWord	Invalid: Server tag missing dimension 2 address.
dintarraytag [1,3]	Array Element	Boolean	Invalid: Boolean not allowed for array elements.
dintarraytag [1,3]	Array Element	DWord	Value = 259
dintarraytag {10}	Array w/o Offset	Byte	Value = [68,73,78,84,255,255,255,255,9,10]
dintarraytag {2}{5}	Array w/o Offset	DWord	Value = [68,73,78,84,256] [257,258,259,9,10]
dintarraytag {1}	Array w/o Offset	DWord	Value = 68
dintarraytag {1}	Array w/o Offset	Boolean	Invalid: Bad data type.
dintarraytag [1,3]{4}	Array w/ Offset	DWord	Value = [259,9,10,11]
dintarraytag . 3	Bit	Boolean	Invalid: Tag must reference atomic location.
dintarraytag [1,3] . 3	Bit	Boolean	Value = 0
dintarraytag [1,3] . 0 {32}	Array w/o Offset	Boolean	Value = [1,1,0,0,0,0,0,0,1,0,0,0,0,0,0,0] Bit value for 259
dintarraytag / 1	String	String	Value = "D"
dintarraytag / 3	String	String	Value = "DINT"

#### Advanced Addressing: LINT

Format	Supported Data Types	Notes
<u>Standard</u>	Double*, Date**	None
<u>Array Element</u>	Double*, Date**	The Controller tag must be an array.
<u>Array w/o Offset</u>	Double, Array*	If accessing more than a single element, the Controller tag must be an array.

Format	Supported Data Types	Notes
<b>Array w/ Offset</b>	Double, Array*	The Controller tag must be an array.
<b>Bit</b>	N/A	Not supported.
<b>String</b>	N/A	Not supported.

\*Double value equals face value of Controller tag in float form (non-IEEE floating-point number).

\*\*Date values are in universal time (UTC), not localized time.

## Examples

Examples **highlighted** signify common use cases.

### LINT Controller Tag - linttag = 2007-01-01T16:46:40.000 (date) == 1.16767E+15 (decimal)

Server Tag Address	Format	Data Type	Notes
linttag	Standard	Boolean	Invalid: Boolean not supported.
linttag	Standard	Byte	Invalid: Byte not supported.
linttag	Standard	Word	Invalid: Word not supported.
linttag	Standard	Double	Value = 1.16767E+15
linttag	Standard	Date	Value = 2007-01-01T16:46:40.000*
linttag [3]	Array Element	Boolean	Invalid: Tag not an array. Boolean is invalid.
linttag [3]	Array Element	Double	Invalid: Tag not an array.
linttag {3}	Array w/o Offset	Double	Invalid: Tag not an array.
linttag {1}	Array w/o Offset	Double	Value = [1.16767E+15]
linttag {1}	Array w/o Offset	Boolean	Invalid: Bad data type.
linttag [3] {1}	Array w/ Offset	Double	Invalid: Tag not an array.
linttag . 3	Bit	Boolean	Invalid: Syntax/data type not supported.
linttag / 1	String	String	Invalid: Syntax/data type not supported.

\*Date values are in universal time (UTC), not localized time.

### LINT Array Controller Tag -

lintarraytag [2,2] = [0, 1.16767E+15],[9.4666E+14, 9.46746E+14] where:

1.16767E+15 == 2007-01-01T16:46:40.000 (date)

9.4666E+14 == 1999-12-31T17:06:40.000

9.46746E+14 == 2000-01-1T17:00:00.000

0 == 1970-01-01T00:00:00.000

Server Tag Address	Format	Data Type	Notes
lintarraytag	Standard	Boolean	Invalid: Boolean not supported.
lintarraytag	Standard	Byte	Invalid: Byte not supported.
lintarraytag	Standard	Word	Invalid: Word not supported.
lintarraytag	Standard	Double	Invalid: Tag cannot be an array.
lintarraytag	Standard	Date	Invalid: Tag cannot be an array.
lintarraytag [1]	Array Element	Double	Invalid: Server tag missing dimension 2 address.
lintarraytag [1,1]	Array Element	Boolean	Invalid: Boolean not allowed for array elements.
lintarraytag [1,1]	Array Element	Double	Value = 9.46746E+14
lintarraytag [1,1]	Array Element	Date	Value = 2000-01-01T17:00:00.000*
lintarraytag {4}	Array w/o Offset	Double	Value = [0, 1.16767E+15, 9.4666E+14, 9.46746E+14]
lintarraytag {2} {2}	Array w/o Offset	Double	Value = [0, 1.16767E+15][9.4666E+14,

Server Tag Address	Format	Data Type	Notes
			9.46746E+14]
lintarraytag {4}	Array w/o Offset	Date	Invalid: Date array not supported.
lintarraytag {1}	Array w/o Offset	Double	Value = 0
lintarraytag {1}	Array w/o Offset	Boolean	Invalid: Bad data type.
lintarraytag [0,1] {2}	Array w/ Offset	Double	Value = [1.16767E+15, 9.4666E+14]
lintarraytag . 3	Bit	Boolean	Invalid: Syntax/data type not supported.
lintarraytag / 1	String	String	Invalid: Syntax/data type not supported.

\*Date values are in universal time (UTC), not localized time.

## Advanced Addressing: REAL

Format	Supported Data Types	Notes
<u>Standard</u>	Boolean*, Byte, Char**, Word, Short, BCD***, DWord, Long, LBCD, Float****	None
<u>Array Element</u>	Byte, Char**, Word, Short, BCD***, DWord, Long, LBCD, Float****	The Controller tag must be an array.
<u>Array w/o Offset</u>	Boolean Array	<ol style="list-style-type: none"> <li>Use this case to have the bits within a REAL in array form. <ul style="list-style-type: none"> <li><b>Note:</b> This is not an array of REALs in Boolean notation.</li> </ul> </li> <li>Applies to bit-within-REAL only. Example: tag_1.0{32}.</li> <li>.bit + array size cannot exceed 32 bits. Example: tag_1.1{32} exceeds an REAL, tag_1.0{32} does not.</li> <li>Array size must be a multiple of eight (8).</li> </ol>
<u>Array w/o Offset</u>	Byte Array, Char Array**, Word Array, Short Array, BCD Array***, DWord Array, Long Array, LBCD Array, Float Array****	If accessing more than a single element, the Controller tag must be an array.
<u>Array w/ Offset</u>	Byte Array, Char Array**, Word Array, Short Array, BCD Array***, DWord Array, Long Array, LBCD Array, Float Array****	The Controller tag must be an array.
<u>Bit</u>	Boolean	<ol style="list-style-type: none"> <li>The range is limited from 0 to 31.</li> <li>If the Controller tag is an array, the bit class reference must be prefixed by an array element class reference. Example: tag_1 [2,2,3].0. <ul style="list-style-type: none"> <li><b>Note:</b> Float is casted to a DWord to allow referencing of bits.</li> </ul> </li> </ol>
<u>String</u>	String	<ol style="list-style-type: none"> <li>If accessing a single element, the Controller tag need not be an array. <ul style="list-style-type: none"> <li><b>Note:</b> The value of the string is the ASCII equivalent of the REAL value (clamped to 255). Example: SINT = 65 dec = "A".</li> </ul> </li> <li>If accessing more than a single element, the Controller tag must be an array. The value of the string is the null-terminated ASCII equivalent of</li> </ol>

Format	Supported Data Types	Notes
		<p>all the REALs (clamped to 255) in the string. 1 character in string = 1 REAL, clamped to 255.</p> <p>● <b>Note:</b> REAL strings are not packed. For greater efficiency, use SINT strings or the STRING structure instead.</p>

\*non-zero values are clamped to true.

\*\*Values exceeding 255 are clamped to 255.

\*\*\*Values exceeding 65535 are clamped to 65535.

\*\*\*\*Float value is a valid IEEE single precision floating point number.

## Examples

Examples **highlighted** signify common use cases.

### REAL Controller Tag - realtag = 512.5 (decimal)

Server Tag Address	Format	Data Type	Notes
realtag	Standard	Boolean	Value = true
realtag	Standard	Byte	Value = 255
realtag	Standard	Word	Value = 512
realtag	Standard	DWord	Value = 512
realtag	Standard	Float	Value = 512.5
realtag [3]	Array Element	Boolean	Invalid: Tag not an array. Also, Boolean is invalid.
realtag [3]	Array Element	DWord	Invalid: Tag not an array
realtag {3}	Array w/o Offset	DWord	Invalid: Tag not an array
realtag {1}	Array w/o Offset	Float	Value = [512.5]
realtag {1}	Array w/o Offset	Boolean	Invalid: Bad data type
realtag [3] {1}	Array w/ Offset	Float	Invalid: Tag not an array
realtag . 3	Bit	Boolean	Value = true
realtag . 0 {32}	Array w/o Offset	Boolean	Value = [0,0,0,0,0,0,0,0,0,1,0,0,0,0,0,0,...0] Bit value for 512
realtag / 1	String	String	Value = unprintable character = 255 decimal
realtag / 4	String	String	Invalid: Tag not an array.

### REAL Array Controller Tag - realarraytag [4,4] = [[82.1,69.2,65.3,76.4],[256.5,257.6,258.7,259.8],[9.0,10.0,11.0,12.0],[13.0,14.0,15.0,16.0]]

Server Tag Address	Format	Data Type	Notes
realarraytag	Standard	Boolean	Invalid: Tag cannot be an array.
realarraytag	Standard	Byte	Invalid: Tag cannot be an array.
realarraytag	Standard	Word	Invalid: Tag cannot be an array.
realarraytag	Standard	DWord	Invalid: Tag cannot be an array.
realarraytag	Standard	Float	Invalid: Tag cannot be an array.
realarraytag [3]	Array Element	Float	Invalid: Server tag missing dimension 2 address.
realarraytag [1,3]	Array Element	Boolean	Invalid: Boolean not allowed for array elements.
realarraytag [1,3]	Array Element	Float	Value = 259.8

Server Tag Address	Format	Data Type	Notes
realarraytag {10}	Array w/o Offset	Byte	Value = [82,69,65,76,255,255,255,255,9,10]
realarraytag {2} {5}	Array w/o Offset	Float	Value = [82.1,69.2,65.3,76.4,256.5] [257.6,258.7,259.8,9,10]
realarraytag {1}	Array w/o Offset	Float	Value = 82.1
realarraytag {1}	Array w/o Offset	Boolean	Invalid: Bad data type.
realarraytag [1,3] {4}	Array w/ Offset	Float	Value = [259.8,9.0,10.0,11.0]
realarraytag . 3	Bit	Boolean	Invalid: Tag must reference atomic location.
realarraytag [1,3] . 3	Bit	Boolean	Value = 0
realarraytag [1,3] . 0 {32}	Array w/o Offset	Boolean	Value = [1,1,0,0,0,0,0,0,1,0,0,0,0,0,0] Bit value for 259
realarraytag / 1	String	String	Value = "R"
realarraytag / 3	String	String	Value = "REAL"

## Advanced Addressing: USINT

Format	Supported Data Types	Notes
<b>Standard</b>	Byte	None
<b>Array Element</b>	Byte	The Controller tag must be an array.
<b>Array w/o Offset</b>	Boolean Array	<ol style="list-style-type: none"> <li>Use this case to have the bits within an USINT in array form. <ul style="list-style-type: none"> <li><b>Note:</b> This is not an array of USINTs in Boolean notation.</li> </ul> </li> <li>Applies to bit-within-USINT only. Example: tag_1.0{8}.</li> <li>.bit + array size cannot exceed 8 bits. Example: tag_1.1{8} exceeds an USINT, tag_1.0{8} does not.</li> </ol>
<b>Array w/o Offset</b>	Byte Array	If accessing more than a single element, the Controller tag must be an array.
<b>Array w/ Offset</b>	Byte Array	The Controller tag must be an array.
<b>Bit</b>	Boolean	<ol style="list-style-type: none"> <li>The range is limited from 0 to 7.</li> <li>If the Controller tag is an array, the bit class reference must be prefixed by an array element class reference. Example: tag_1 [2,2,3].0.</li> </ol>
<b>String</b>	N/A	Not Supported

## Examples

Examples highlighted signify common use cases.

### USINT Controller Tag - usinttag = 122 (decimal)

Server Tag Address	Format	Data Type	Notes
usinttag	Standard	Boolean	Value = true
usinttag	Standard	Byte	Value = 122
usinttag	Standard	Word	Invalid: Word not supported
usinttag	Standard	DWord	Invalid: DWord not supported

Server Tag Address	Format	Data Type	Notes
usinttag	Standard	Float	Invalid: Float not supported
usinttag [3]	Array Element	Boolean	Invalid: Tag not an array. Also, Boolean is invalid
usinttag [3]	Array Element	Byte	Invalid: Tag not an array
usinttag {3}	Array w/o Offset	Byte	Invalid: Tag not an array
usinttag {1}	Array w/o Offset	Byte	Value = [122]
usinttag {1}	Array w/o Offset	Boolean	Invalid: Bad data type
usinttag [3]{1}	Array w/ Offset	Byte	Invalid: Tag not an array
usinttag . 3	Bit	Boolean	Value = true
usinttag . 0 {8}	Array w/o Offset	Boolean	Value = [0,1,0,1,1,1,1,0] Bit value of 122
usinttag / 1	String	String	Value = "z"
usinttag / 4	String	String	Invalid: Tag not an array

**USINT Array Controller Tag - usintarraytag [4,4] = [[83,73,78,84],[5,6,7,8],[9,10,11,12],[13,14,15,16]]**

Server Tag Address	Format	Data Type	Notes
usintarraytag	Standard	Boolean	Invalid: Tag cannot be an array
usintarraytag	Standard	Byte	Invalid: Tag cannot be an array
usintarraytag	Standard	Word	Invalid: Tag cannot be an array
usintarraytag	Standard	DWord	Invalid: Tag cannot be an array
usintarraytag	Standard	Float	Invalid: Tag cannot be an array
usintarraytag [3]	Array Element	Byte	Invalid: Server tag missing dimension 2 address
usintarraytag [1,3]	Array Element	Boolean	Invalid: Boolean not allowed for array elements
usintarraytag [1,3]	Array Element	Byte	Value = 8
usintarraytag {10}	Array w/o Offset	Byte	Value = [83,73,78,84,5,6,7,8,9,10]
usintarraytag {2} {5}	Array w/o Offset	Word	Value = [83,73,78,84,5] [6,7,8,9,10]
usintarraytag {1}	Array w/o Offset	Byte	Value = 83
usintarraytag {1}	Array w/o Offset	Boolean	Invalid: Bad data type
usintarraytag [1,3] {4}	Array w/ Offset	Byte	Value = [8,9,10,11]
usintarraytag . 3	Bit	Boolean	Invalid: Tag must reference atomic location
usintarraytag [1,3] . 3	Bit	Boolean	Value = 1
usintarraytag [1,3] . 0 {8}	Array w/o Offset	Boolean	Value = [0,0,0,1,0,0,0,0]
usintarraytag / 1	String	String	Invalid: Syntax / data type not supported
usintarraytag / 4	String	String	Invalid: Syntax / data type not supported

## Advanced Addressing: UINT

Format	Supported Data Types	Notes
<u>Standard</u>	Word, BCD	None
<u>Array Element</u>	Word, BCD	The Controller tag must be an array.
<u>Array w/o Offset</u>	Boolean Array	<ol style="list-style-type: none"> <li>Use this case to have the bits within a UINT in array form. <ul style="list-style-type: none"> <li><b>Note:</b> This is not an array of UINTs in Boolean notation.</li> </ul> </li> <li>Applies to bit-within-UINT only. Example: tag_1.0{16}.</li> <li>.bit + array size cannot exceed 8 bits. Example: tag_1.1{16} exceeds an UINT, tag_1.0{16} does not.</li> <li>Array size must be a multiple of eight (8).</li> </ol>
<u>Array w/o Offset</u>	Word Array, BCD Array	If accessing more than a single element, the Controller tag must be an array.
<u>Array w/ Offset</u>	Word Array, BCD Array	The Controller tag must be an array.
<u>Bit</u>	Boolean	<ol style="list-style-type: none"> <li>The range is limited from 0 to 15.</li> <li>If the Controller tag is an array, the bit class reference must be prefixed by an array element class reference. Example: tag_1 [2,2,3].0.</li> </ol>
<u>String</u>	N/A	Not Supported

### Examples

Examples **highlighted** signify common use cases.

#### UINT Controller Tag - uinttag = 65534 (decimal)

Server Tag Address	Class	Data Type	Notes
uinttag	Standard	Boolean	Invalid: Boolean not supported.
uinttag	Standard	Byte	Invalid: Byte not supported.
uinttag	Standard	Word	Value = 65534
uinttag	Standard	DWord	Invalid: DWord not supported.
uinttag	Standard	Float	Invalid: Float not supported.
uinttag [3]	Array Element	Boolean	Invalid: Tag not an array. Boolean is invalid.
uinttag [3]	Array Element	Byte	Invalid: Tag not an array.
uinttag {3}	Array w/o Offset	Byte	Invalid: Tag not an array.
uinttag {1}	Array w/o Offset	Byte	Value = [65534]
uinttag {1}	Array w/o Offset	Boolean	Invalid: Bad data type.
uinttag [3] {1}	Array w/ Offset	Word	Invalid: Tag not an array.
uinttag . 3	Bit	Boolean	Value = true
uinttag . 0 {16}	Array w/o Offset	Boolean	Value = [0,1,1,1,1,1,1,1,1,1,1,1,1,1,1,1] Bit value of 65534
uinttag / 1	String	String	Invalid: Syntax / data type not supported.
uinttag / 4	String	String	Invalid: Syntax / data type not supported.

UINT Array Controller Tag - uintarraytag [4,4] = [[73,78,84,255],[256,257,258,259],[9,10,11,12],[13,14,15,16]]

Server Tag Address	Format	Data Type	Notes
uintarraytag	Standard	Boolean	Invalid: Tag cannot be an array.
uintarraytag	Standard	Byte	Invalid: Tag cannot be an array.
uintarraytag	Standard	Word	Invalid: Tag cannot be an array.
uintarraytag	Standard	DWord	Invalid: Tag cannot be an array.
uintarraytag	Standard	Float	Invalid: Tag cannot be an array.
uintarraytag [3]	Array Element	Word	Invalid: Server tag missing dimension 2 address.
uintarraytag [1,3]	Array Element	Boolean	Invalid: Boolean not allowed for array elements.
uintarraytag [1,3]	Array Element	Word	Value = 259
uintarraytag {10}	Array w/o Offset	BCD	Value = [49,54,54,165,100,101,102,103,9,10]
uintarraytag {2} {5}	Array w/o Offset	Word	Value = [73,78,84,255,256] [257,258,259,9,10]
uintarraytag {1}	Array w/o Offset	Word	Value = 73
uintarraytag {1}	Array w/o Offset	Boolean	Invalid: Bad data type.
uintarraytag [1,3] {4}	Array w/ Offset	Byte	Value = [259,9,10,11]
uintarraytag . 3	Bit	Boolean	Invalid: Tag must reference atomic location.
uintarraytag [1,3] . 3	Bit	Boolean	Value = 0
uintarraytag [1,3] . 0 {16}	Array w/o Offset	Boolean	Value = [0,0,0,1,0,0,0,0] Value = [1,1,0,0,0,0,0,0,1,0,0,0,0,0,0,0] Bit value for 259
uintarraytag / 1	String	String	Invalid: Syntax / data type not supported.
uintarraytag / 3	String	String	Invalid: Syntax / data type not supported.

### Advanced Addressing: UDINT

Format	Supported Data Types	Notes
<u>Standard</u>	DWord, LBCD	None
<u>Array Element</u>	DWord, LBCD	The Controller tag must be an array.
<u>Array w/o Offset</u>	Boolean Array	<ol style="list-style-type: none"> <li>Use this case to have the bits within an UDINT in array form.                             <ul style="list-style-type: none"> <li><b>Note:</b> This is not an array of UDINTs in Boolean notation.</li> </ul> </li> <li>Applies to bit-within-UDINT only. Example: tag_1.0{32}.</li> <li>.bit + array size cannot exceed 32 bits. Example: tag_1.1{32} exceeds an UINT, tag_1.0{32} does not.</li> <li>Array size must be a multiple of (eight) 8.</li> </ol>
<u>Array w/o Offset</u>	DWord Array, LBCD Array	If accessing more than a single element, the Controller tag must be an array.
<u>Array w/ Offset</u>	DWord Array, LBCD Array	The Controller tag must be an array.
<u>Bit</u>	Boolean	<ol style="list-style-type: none"> <li>The range is limited from 0 to 31.</li> <li>If Controller tag is an array, bit</li> </ol>

Format	Supported Data Types	Notes
		class reference must be prefixed by an array element class reference. Example: tag_1 [2,2,3].0
String	N/A	Not supported

### Examples

Examples highlighted signify common use cases.

#### UDINT Controller Tag - udinttag = 70000 (decimal)

Server Tag Address	Format	Data Type	Notes
udinttag	Standard	Boolean	Invalid: Boolean not supported
udinttag	Standard	Byte	Invalid: Byte not supported
udinttag	Standard	Word	Invalid: Word not supported
udinttag	Standard	DWord	Value = 70000
udinttag	Standard	LBCD	Value = 11170
udinttag [3]	Array Element	Boolean	Invalid: Tag not an array. Boolean is invalid.
udinttag [3]	Array Element	DWord	Invalid: Tag not an array
udinttag {3}	Array w/o Offset	DWord	Invalid: Tag not an array
udinttag {1}	Array w/o Offset	DWord	Value = [70000]
udinttag {1}	Array w/o Offset	Boolean	Invalid: Boolean Array not supported
udinttag [3] {1}	Array w/ Offset	DWord	Invalid: Tag not an array
udinttag . 3	Bit	Boolean	Value = False
udinttag . 0 {32}	Array w/o Offset	Boolean	Value = [0,0,0,0,1,1,1,0,1,0,0,0,1,0,0,0,1,0,...0] Bit value for 70000
udinttag / 1	String	String	Invalid: Syntax/data type not supported
udinttag / 4	String	String	Invalid: Syntax/data type not supported

#### UDINT Array Controller Tag - udintarraytag [4,4] = [[68,73,78,84],[256,257,258,259],[9,10,11,12],[13,14,15,16]]

Server Tag Address	Format	Data Type	Notes
udintarraytag	Standard	Boolean	Invalid: Boolean not supported
udintarraytag	Standard	Byte	Invalid: Byte not supported
udintarraytag	Standard	Word	Invalid: Word not supported
udintarraytag	Standard	DWord	Invalid: Tag cannot be an array
udintarraytag	Standard	Float	Invalid: Float not supported
udintarraytag [3]	Array Element	DWord	Invalid: Server tag missing dimension 2 address.
udintarraytag [1,3]	Array Element	Boolean	Invalid: Boolean not allowed for array elements
udintarraytag [1,3]	Array Element	DWord	Value = 259
udintarraytag {10}	Array w/o Offset	LCBD	Value = [44,49,54,54,100,101,102,103,9,10]
udintarraytag {2}{5}	Array w/o Offset	DWord	Value = [68,73,78,84,256] [257,258,259,9,10]
udintarraytag {1}	Array w/o Offset	DWord	Value = 68
udintarraytag {1}	Array w/o Offset	Boolean	Invalid: Bad data type.

Server Tag Address	Format	Data Type	Notes
udintarraytag [1,3] {4}	Array w/ Offset	DWord	Value = [259,9,10,11]
udintarraytag . 3	Bit	Boolean	Invalid: Tag must reference atomic location.
udintarraytag [1,3] . 3	Bit	Boolean	Value = False
udintarraytag [1,3] .0 {32}	Array w/o Offset	Boolean	Value = [1,1,0,0,0,0,0,0,1,0,0,0,0,0,0]
udintarraytag / 1	String	String	Invalid: Syntax/data type not supported
udintarraytag / 3	String	String	Invalid: Syntax/data type not supported

## Advanced Addressing: ULINT

Format	Supported Data Types	Notes
<b>Standard</b>	Double*	None
<b>Array Element</b>	Double*	The Controller tag must be an array.
<b>Array w/o Offset</b>	Double, Array*	If accessing more than a single element, the Controller tag must be an array.
<b>Array w/ Offset</b>	Double, Array*	The Controller tag must be an array.
<b>Bit</b>	N/A	Not supported
<b>String</b>	N/A	Not supported

\*Double value equals face value of Controller tag in float form (non-IEEE floating-point number).

### Examples

Examples **highlighted** signify common use cases.

#### ULINT Controller Tag - ulinttag = 1.8446744073709560e+19 (decimal)

Server Tag Address	Format	Data Type	Notes
ulinttag	Standard	Boolean	Invalid: Boolean not supported
ulinttag	Standard	Byte	Invalid: Byte not supported
ulinttag	Standard	Word	Invalid: Word not supported
ulinttag	Standard	Double	Value = 1.8446744073709560e+19
ulinttag [3]	Array Element	Boolean	Invalid: Tag not an array. Boolean is invalid.
ulinttag [3]	Array Element	Double	Invalid: Tag not an array
ulinttag {3}	Array w/o Offset	Double	Invalid: Tag not an array
ulinttag {1}	Array w/o Offset	Double	Value = [1.8446744073709560e+19]
ulinttag {1}	Array w/o Offset	Boolean	Invalid: Boolean array not supported
ulinttag [3] {1}	Array w/ Offset	Double	Invalid: Tag not an array
ulinttag . 3	Bit	Boolean	Invalid: Syntax/data type not supported
ulinttag / 1	String	String	Invalid: Syntax/data type not supported

#### ULINT Array Controller Tag -

ulintarraytag [2,2] = [0, 1.16767E+15],[9.4666E+14, 1.8446744073709560e+19]

Server Tag Address	Format	Data Type	Notes
ulintarraytag	Standard	Boolean	Invalid: Boolean not supported
ulintarraytag	Standard	Byte	Invalid: Byte not supported

Server Tag Address	Format	Data Type	Notes
ulintarraytag	Standard	Word	Invalid: Word not supported
ulintarraytag	Standard	Double	Invalid: Tag cannot be an array
ulintarraytag	Standard	Date	Invalid: Date not supported
ulintarraytag [1]	Array Element	Double	Invalid: Server tag missing dimension 2 address.
ulintarraytag [1,1]	Array Element	Boolean	Invalid: Boolean not allowed for array elements.
ulintarraytag [1,1]	Array Element	Double	Value = 1.8446744073709560e+19
ulintarraytag {4}	Array w/o Offset	Double	Value = [0, 1.16767E+15, 9.4666E+14, 1.8446744073709560e+19]
ulintarraytag {2} {2}	Array w/o Offset	Double	Value =[0, 1.16767E+15][ 9.4666E+14, 1.8446744073709560e+19]
ulintarraytag {4}	Array w/o Offset	Date	Invalid: Date array not supported
ulintarraytag {1}	Array w/o Offset	Double	Value = 0
ulintarraytag {1}	Array w/o Offset	Boolean	Invalid: Boolean array not supported
ulintarraytag [0,1] {2}	Array w/ Offset	Double	Value = [1.16767E+15, 9.4666E+14]
ulintarraytag . 3	Bit	Boolean	Invalid: Syntax/data type not supported
ulintarraytag / 1	String	String	Invalid: Syntax/data type not supported

### Advanced Addressing: LREAL

Format	Supported Data Types	Notes
<u>Standard</u>	Double	None
<u>Array Element</u>	Double	The Controller tag must be an array.
<u>Array w/o Offset</u>	Double Array	If accessing more than a single element, the Controller tag must be an array.
<u>Array w/ Offset</u>	Double Array	The Controller tag must be an array.
<u>Bit</u>	N/A	Not supported
<u>String</u>	N/A	Not supported

### Examples

Examples **highlighted** signify common use cases.

#### LREAL Controller Tag - lrealtag = 1.7976931348623157E+308 (decimal)

Server Tag Address	Format	Data Type	Notes
lrealtag	Standard	Boolean	Invalid: Boolean not supported
lrealtag	Standard	Byte	Invalid: Byte not supported
lrealtag	Standard	Word	Invalid: Word not supported
lrealtag	Standard	Double	Value = 1.7976931348623157E+308
lrealtag [3]	Array Element	Boolean	Invalid: Tag not an array. Also, Boolean is invalid.
lrealtag {1}	Array w/o Offset	Double	Value = [1.7976931348623157E+308]
lrealtag {1}	Array w/o Offset	Boolean	Invalid: Boolean array not supported
lrealtag [3] {1}	Array w/ Offset	Double	Invalid: Tag not an array
lrealtag . 3	Bit	Boolean	Invalid: Syntax / data type not supported

Server Tag Address	Format	Data Type	Notes
Irealtag . 0 {32}	Array w/o Offset	Boolean	Invalid: Syntax / data type not supported
Irealtag / 1	String	String	Invalid: Syntax / data type not supported
Irealtag / 4	String	String	Invalid: Syntax / data type not supported

LREAL Array Controller Tag - Irealarraytag [4,4] = [[82.1,69.2,65.3,76.4],[256.5,257.6,258.7,259.8],[9.0,10.0,11.0,12.0],[13.0,14.0,15.0,16.0]]

Server Tag Address	Format	Data Type	Notes
Irealarraytag	Standard	Boolean	Invalid: Tag cannot be an array.
Irealarraytag	Standard	Byte	Invalid: Tag cannot be an array.
Irealarraytag	Standard	Word	Invalid: Tag cannot be an array.
Irealarraytag	Standard	Double	Invalid: Tag cannot be an array.
Irealarraytag [3]	Array Element	Double	Invalid: Server tag missing dimension 2 address.
Irealarraytag [1,3]	Array Element	Boolean	Invalid: Boolean not allowed for array elements.
Irealarraytag [1,1]	Array Element	Double	Value = 257.6
Irealarraytag {2} {5}	Array w/o Offset	Double	Value = [82.1,69.2,65.3,76.4,256.5] [257.6,258.7,259.8,9,10]
Irealarraytag {1}	Array w/o Offset	Double	Value = 82.1
Irealarraytag {1}	Array w/o Offset	Boolean	Invalid: Boolean Array not supported
Irealarraytag [1,3] {4}	Array w/ Offset	Double	Value = [259.8,9.0,10.0,11.0]
Irealarraytag . 3	Bit	Boolean	Invalid: Syntax / data type not supported.
Irealarraytag / 1	String	String	Invalid: Syntax / data type not supported.

## Advanced Addressing: TIME32

Format	Supported Data Types	Notes
<b>Standard</b>	<b>String</b> , Long	None
<b>Array Element</b>	<b>String</b> , Long	The Controller tag must be an array.
<b>Array w/o Offset</b>	Long Array	If accessing more than a single element, the Controller tag must be an array.
<b>Array w/ Offset</b>	Long Array	The Controller tag must be an array.
<b>Bit</b>	N/A	Not supported
<b>String</b>	N/A	String with length specifier is not supported.

 **Tip:** Data type in **bold** represents the default data type.

### Examples

Examples **highlighted** signify common use cases.

TIME32 Controller Tag - time32tag = -2147483647 (decimal)

Server Tag Address	Format	Data Type	Notes
time32tag	Standard	String	Value = T32#-35m_47s_483ms_647us
time32tag	Standard	Long	-2147483647

Server Tag Address	Format	Data Type	Notes
time32tag	Standard	DWord	Invalid: DWord not supported
time32tag	Standard	Boolean	Invalid: Boolean not supported
time32tag [3]	Array Element	String	Invalid: Tag not an array
time32tag {1}	Array w/o Offset	Long Array	Value = [-2147483647]
time32tag {1}	Array w/o Offset	String Array	Invalid: String array not supported
time32tag [3] {1}	Array w/ Offset	Long Array	Invalid: Tag not an array
time32tag . 3	Bit	Boolean	Invalid: Syntax / data type not supported
time32tag . 0 {32}	Array w/o Offset	Boolean Array	Invalid: Syntax / data type not supported
time32tag / 1	String	String	Invalid: String length not supported
time32tag / 4	String	String	Invalid: String length not supported

**TIME32 Array Controller Tag - time32arraytag [4,4] = [[1,2,3,4],[500,600,700,800],[90000,100000,110000,120000],[13000000,14000000,15000000,16000000]] (decimal)**

Server Tag Address	Format	Data Type	Notes
time32arraytag	Standard	String	T32#1us (only first element is read)
time32arraytag	Standard	Long	1 (only first element is read)
time32arraytag	Standard	Boolean	Invalid: Tag cannot be an array. Boolean not supported.
time32arraytag [1,1]	Array Element	String	T32#600us
time32arraytag [2,2]	Array Element	Long	Value = 110000
time32arraytag [3]	Array Element	Long	Invalid: Server tag missing dimension 2 address.
time32arraytag [1,3]	Array Element	Boolean	Invalid: Boolean not allowed for array elements.
time32arraytag {2} {5}	Array w/o Offset	Long Array	Value = [1,2,3,4,500] [600,700,800,90000,100000]
time32arraytag {1}	Array w/o Offset	Long Array	Value = [1]
time32arraytag {1}	Array w/o Offset	String Array	Invalid: String Array not supported
time32arraytag [1,2] {3}	Array w/ Offset	Long Array	Value = [700,800,90000]
time32arraytag . 3	Bit	Boolean	Invalid: Syntax / data type not supported
time32arraytag / 1	String	String	Invalid: String length not supported

## Advanced Addressing: TIME

Format	Supported Data Types	Notes
<b>Standard</b>	<b>String</b> , LLong	None
<b>Array Element</b>	<b>String</b> , LLong	The Controller tag must be an array.
<b>Array w/o Offset</b>	LLong Array	If accessing more than a single element, the Controller tag must be an array.
<b>Array w/ Offset</b>	LLong Array	The Controller tag must be an array.
<b>Bit</b>	N/A	Not supported
<b>String</b>	N/A	String with length specifier is not supported.

 **Tip:** Data type in **bold** represents the default data type.

## Examples

Examples **highlighted** signify common use cases.

### TIME Controller Tag - timetag = -2725199999999 (decimal)

Server Tag Address	Format	Data Type	Notes
timetag	Standard	String	Value = T#-31d_12h_59m_59s_999ms_999us
timetag	Standard	LLong	-2725199999999
timetag	Standard	QWord	Invalid: QWord not supported
timetag	Standard	Boolean	Invalid: Boolean not supported
timetag [3]	Array Element	String	Invalid: Tag not an array
timetag {1}	Array w/o Offset	LLong Array	Value = [-2725199999999]
timetag {1}	Array w/o Offset	String Array	Invalid: String array not supported
timetag [3] {1}	Array w/ Offset	LLong Array	Invalid: Tag not an array
timetag . 3	Bit	Boolean	Invalid: Syntax / data type not supported
timetag . 0 {32}	Array w/o Offset	Boolean Array	Invalid: Syntax / data type not supported
timetag / 1	String	String	Invalid: String length not supported
timetag / 4	String	String	Invalid: String length not supported

### TIME Array Controller Tag - timearraytag [4,4] = [[1,2,3,4],[500,600,700,800],[90000,100000,110000,120000],[13000000,14000000,15000000,16000000]] (decimal)

Server Tag Address	Format	Data Type	Notes
timearraytag	Standard	String	T#1us (only first element is read)
timearraytag	Standard	LLong	1 (only first element is read)
timearraytag	Standard	Boolean	Invalid: Tag cannot be an array. Boolean not supported.
timearraytag [1,1]	Array Element	String	T#600us
timearraytag [2,2]	Array Element	LLong	Value = 110000
timearraytag [3]	Array Element	LLong	Invalid: Server tag missing dimension 2 address.
timearraytag [1,3]	Array Element	Boolean	Invalid: Boolean not allowed for array elements.
timearraytag {2} {5}	Array w/o Offset	LLong Array	Value = [1,2,3,4,500] [600,700,800,90000,100000]
timearraytag {1}	Array w/o Offset	LLong Array	Value = [1]
timearraytag {1}	Array w/o Offset	String Array	Invalid: String Array not supported
timearraytag [1,3] {4}	Array w/ Offset	LLong Array	Value = [800,90000,100000,110000]
timearraytag . 3	Bit	Boolean	Invalid: Syntax / data type not supported
timearraytag / 1	String	String	Invalid: String length not supported

## Advanced Addressing: LTIME

Format	Supported Data Types	Notes
<b>Standard</b>	String, LLong	None
<b>Array Element</b>	String, LLong	The Controller tag must be an array.
<b>Array w/o Offset</b>	LLong Array	If accessing more than a single element, the Controller tag must be an array.

Format	Supported Data Types	Notes
<b>Array w/ Offset</b>	LLong Array	The Controller tag must be an array.
<b>Bit</b>	N/A	Not supported
<b>String</b>	N/A	String with length specifier is not supported.

Tip: Data type in **bold** represents the default data type.

## Examples

Examples highlighted signify common use cases.

### LTIME Controller Tag - ltimetag = -272519999999999 (decimal)

Server Tag Address	Format	Data Type	Notes
ltimetag	Standard	String	Value = LT#-31d_12h_59m_59s_999ms_999us_999ns
ltimetag	Standard	LLong	-272519999999999
ltimetag	Standard	QWord	Invalid: QWord not supported
ltimetag	Standard	Boolean	Invalid: Boolean not supported
ltimetag [3]	Array Element	String	Invalid: Tag not an array
ltimetag {1}	Array w/o Offset	LLong Array	Value = [-272519999999999]
ltimetag {1}	Array w/o Offset	String Array	Invalid: String array not supported
ltimetag [3] {1}	Array w/ Offset	LLong Array	Invalid: Tag not an array
ltimetag . 3	Bit	Boolean	Invalid: Syntax / data type not supported
ltimetag . 0 {32}	Array w/o Offset	Boolean Array	Invalid: Syntax / data type not supported
ltimetag / 1	String	String	Invalid: String length not supported
ltimetag / 4	String	String	Invalid: String length not supported

### LTIME Array Controller Tag - ltimearraytag [4,4] = [[1,2,3,4],[500,600,700,800],[90000,100000,110000,120000],[13000000,14000000,15000000,16000000]] (decimal)

Server Tag Address	Format	Data Type	Notes
ltimearraytag	Standard	String	T#1us (only first element is read)
ltimearraytag	Standard	LLong	1 (only first element is read)
ltimearraytag	Standard	Boolean	Invalid: Tag cannot be an array. Boolean not supported.
ltimearraytag [1,1]	Array Element	String	T#600ns
ltimearraytag [2,2]	Array Element	LLong	Value = 110000
ltimearraytag [3]	Array Element	LLong	Invalid: Server tag missing dimension 2 address.
ltimearraytag [1,3]	Array Element	Boolean	Invalid: Boolean not allowed for array elements.
ltimearraytag {2} {5}	Array w/o Offset	LLong Array	Value = [1,2,3,4,500] [600,700,800,90000,100000]
ltimearraytag {1}	Array w/o Offset	LLong Array	Value = [1]
ltimearraytag {1}	Array w/o Offset	String Array	Invalid: String Array not supported
ltimearraytag [2,2] {4}	Array w/ Offset	LLong Array	Value = [110000,120000,13000000,14000000]
ltimearraytag . 3	Bit	Boolean	Invalid: Syntax / data type not supported
ltimearraytag / 1	String	String	Invalid: String length not supported

## File Listing

Select a link from the list below for information on a specific file supported by various device models.

[Output Files](#)

[Input Files](#)

[Status Files](#)

[Binary Files](#)

[Timer Files](#)

[Counter Files](#)

[Control Files](#)

[Integer Files](#)

[Float Files](#)

[ASCII Files](#)

[String Files](#)

[BCD Files](#)

[Long Files](#)

[MicroLogix PID Files](#)

[PID Files](#)

[MicroLogix Message Files](#)

[Message Files](#)

[Block Transfer Files](#)

## Function File Listing

[High-Speed Counter File \(HSC\)](#)

[Real-Time Clock File \(RTC\)](#)

[Channel 0 Communication Status File \(CS0\)](#)

[Channel 1 Communication Status File \(CS1\)](#)

[I/O Module Status File \(IOS\)](#)

For more information on device models and their supported files, refer to [Address Descriptions](#).

## Output Files

The syntax for accessing data in the output file differs depending on the PLC model. Arrays are not supported for output files. The default data types are shown in **bold**.

### PLC-5 Syntax

Syntax	Data Type	Access
O:<word>	Short, <b>Word</b> , BCD	Read/Write
O:<word>/<bit>	<b>Boolean</b>	Read/Write
O/bit	<b>Boolean</b>	Read/Write

**Note** : Word and bit address information is in octal for PLC-5 models. This follows the convention of the programming software.

### MicroLogix Syntax

Syntax	Data Type	Access
O:<word>	Short, <b>Word</b> , BCD	Read/Write
O:<word>/<bit>	<b>Boolean</b>	Read/Write
O/bit	<b>Boolean</b>	Read/Write

MicroLogix models have two types of I/O: embedded I/O and expansion I/O (not applicable for MicroLogix 1000). Embedded I/O resides with the CPU base unit while Expansion I/O plugs into the CPU base unit. The table below lists the I/O capabilities of each MicroLogix model.

MicroLogix Model	Embedded I/O	Expansion I/O
1000	Slot 0	N/A
1100	Slot 0	Slots 1-4
1200	Slot 0	Slots 1-6
1400	Slot 0	Slots 1-7
1500	Slot 0	Slots 1-16

The address syntax for MicroLogix I/O references a zero-based word offset, not a slot. Users must determine the word offset to a particular slot. This requires knowledge of the modules and their respective size in words. The table below specifies the size of some available modules; however, it is recommended that users consult both the MicroLogix documentation and the controller project to determine the module's true word size.

### MicroLogix Embedded I/O Word Sizes

MicroLogix Model	# Input Words	# Output Words
1000	2	1
1100	6	4
1200	4	4
1400	8	6
1500	4	4

### MicroLogix Expansion I/O Word Sizes

Modules	# Input Words	# Output Words
1769-HSC	35	34
1769-IA8I	1	0
1769-IA16	1	0
1769-IF4	6	0
1769-IF4XOF2	8	2
1769-IF8	12	1
1769-IM12	1	0
1769-IQ16	1	0
1769-IQ6XOW4	1	1
1769-IQ16F	1	0
1769-IQ32	2	0
1769-IR6	8	0
1769-IT6	8	0
1769-OA8	0	1
1769-OA16	0	1
1769-OB8	0	1
1769-OB16	0	1
1769-OB16P	0	1
1769-OB32	0	2
1769-OF2	2	2
1769-OF8C	11	9
1769-OF8V	11	9
1769-OV16	0	1

Modules	# Input Words	# Output Words
1769-OW8	0	1
1769-OW16	0	1
1769-OW8I	0	1
1769-SDN	66	2
1769-SM1	12	12
1769-SM2	7	7
1769-ASCII	108	108
1762-IA8	1	0
1762-IF2OF2	6	2
1762-IF4	7	0
1762-IQ8	1	0
1762-IQ8OW6	1	1
1762-IQ16	1	0
1762-OA8	0	1
1762-OB8	0	1
1762-OB16	0	1
1762-OW8	0	1
1762-OW16	0	1
1762-IT4	6	0
1762-IR4	6	0
1762-OF4	2	4
1762-OX6I	0	1

### Calculation

Output Word Offset for slot x = # Output Words in slot 0 through slot (x-1).

#### Notes:

1. The Embedded I/O needs to be taken into account when offsetting to Expansion I/O.
2. The number of Input words does not factor into the calculation for Output Word Offset.

### I/O Example

Let

Slot 0 = MicroLogix 1500 LRP Series C = 4 Output Words

Slot 1 = 1769-OF2 = 2 Output Words

Slot 2 = 1769-OW8 = 1 Output Word

Slot 3 = 1769-IA16 = 0 Output Word

Slot 4 = 1769-OF8V = 9 Output Word

Bit 5 of Slot 4 = 4 + 2 + 1 = 7 words = O:7/5

### SLC 500 Syntax

The default data types are shown in **bold**.

Syntax	Data Type	Access
O:<slot>	Short, <b>Word</b> , BCD	Read Only
O:<slot>.<word>	Short, <b>Word</b> , BCD	Read Only
O:<slot>/<bit>	<b>Boolean</b>	Read Only
O:<slot>.<word>/<bit>	<b>Boolean</b>	Read Only

### Ranges

PLC Model	Min. Slot	Max. Slot	Max. Word
MicroLogix	N/A	N/A	2047
SLC 500 Fixed I/O	N/A	N/A	1
SLC 500 Modular I/O	1	30	*
PLC-5 Series	N/A	N/A	277 (octal)

\*The number of Input or Output words available for each I/O module can be found in the [SLC 500 Modular I/O Selection Guide](#).

### Examples

MicroLogix	Description
O:0	word 0
O/2	bit 2
O:0/5	bit 5

SLC 500 Fixed I/O	Description
O:0	word 0
O:1	word 1
O/16	bit 16
O:1/0	bit 0 word 1 (same as O/16)

PLC5*	Description
O:0	word 0
O:37	word 31 (37 octal = 31 decimal)
O/42	bit 34 (42 octal = 34 decimal)
O:2/2	bit 2 word 2 (same as O/42)

\*Addresses are in Octal.

SLC 500 Modular I/O	Description
O:1	word 0 slot 1
O:1.0	word 0 slot 1 (same as O:1)
O:12	word 0 slot 12
O:12.2	word 2 slot 12
O:4.0/0	bit 0 word 0 slot 4
O:4/0	bit 0 slot 4 (same as O:4.0/0)
O:4.2/0	bit 0 word 2 slot 4
O:4/32	bit 32 slot 4 (same as O:4.2/0)

### Input Files

The syntax for accessing data in the input file differs depending on the PLC model. Arrays are not supported for input files. The default data types are shown in **bold**.

### PLC-5 Syntax

Syntax	Data Type	Access
I:<word>	Short, <b>Word</b> , BCD	Read/Write
I:<word>/<bit>	<b>Boolean</b>	Read/Write
I/bit	<b>Boolean</b>	Read/Write

● **Note:** Word and bit address information is in octal for PLC-5 models. This follows the convention of the programming software.

### MicroLogix Syntax

Syntax	Data Type	Access
I:<word>	Short, <b>Word</b> , BCD	Read/Write
I:<word>/<bit>	<b>Boolean</b>	Read/Write
I/bit	<b>Boolean</b>	Read/Write

MicroLogix models have two types of I/O: embedded I/O and expansion I/O (not applicable for MicroLogix 1000). Embedded I/O resides with the CPU base unit while Expansion I/O plugs into the CPU base unit. The table below lists the I/O capabilities of each MicroLogix model.

MicroLogix Model	Embedded I/O	Expansion I/O
1000	Slot 0	N/A
1100	Slot 0	Slots 1-4
1200	Slot 0	Slots 1-6
1400	Slot 0	Slots 1-7
1500	Slot 0	Slots 1-16

The address syntax for MicroLogix I/O references a zero-based word offset, not a slot. Users must determine the word offset to a particular slot. This requires knowledge of the modules and their respective size in words. The table below specifies the size of some available modules; however, it is recommended that the MicroLogix documentation and controller project be consulted to determine a module's true word size.

### MicroLogix Embedded I/O Word Sizes

MicroLogix Model	# Input Words	# Output Words
1000	2	1
1100	6	4
1200	4	4
1400	8	6
1500	4	4

### MicroLogix Expansion I/O Word Sizes

Modules	# Input Words	# Output Words
1769-HSC	35	34
1769-IA8I	1	0
1769-IA16	1	0
1769-IF4	6	0
1769-IF4XOF2	8	2
1769-IF8	12	1
1769-IM12	1	0
1769-IQ16	1	0
1769-IQ6XOW4	1	1
1769-IQ16F	1	0
1769-IQ32	2	0
1769-IR6	8	0
1769-IT6	8	0
1769-OA8	0	1
1769-OA16	0	1

Modules	# Input Words	# Output Words
1769-OB8	0	1
1769-OB16	0	1
1769-OB16P	0	1
1769-OB32	0	2
1769-OF2	2	2
1769-OF8C	11	9
1769-OF8V	11	9
1769-OV16	0	1
1769-OW8	0	1
1769-OW16	0	1
1769-OW8I	0	1
1769-SDN	66	2
1769-SM1	12	12
1769-SM2	7	7
1769-ASCII	108	108
1762-IA8	1	0
1762-IF2OF2	6	2
1762-IF4	7	0
1762-IQ8	1	0
1762-IQ8OW6	1	1
1762-IQ16	1	0
1762-OA8	0	1
1762-OB8	0	1
1762-OB16	0	1
1762-OW8	0	1
1762-OW16	0	1
1762-IT4	6	0
1762-IR4	6	0
1762-OF4	2	4
1762-OX6I	0	1

### Calculation

Input Word Offset for slot x = # Input Words in slot 0 through slot (x-1).

#### Notes:

1. The Embedded I/O needs to be taken into account when offsetting to Expansion I/O.
2. The number of Output words does not factor into the calculation for Input Word Offset.

### I/O Example

Let

Slot 0 = MicroLogix 1500 LRP Series C = 4 Input Words

Slot 1 = 1769-OF2 = 2 Input Words

Slot 2 = 1769-OW8 = 0 Input Word

Slot 3 = 1769-IA16 = 1 Input Word

Slot 4 = 1769-OF8V = 11 Input Word

Bit 5 of Slot 3 = 4 + 2 = 6 words = I:6/5

### SLC 500 Syntax

Syntax	Data Type	Access
I:<slot>	Short, <b>Word</b> , BCD	Read Only
I:<slot>.<word>	Short, <b>Word</b> , BCD	Read Only
I:<slot>/<bit>	<b>Boolean</b>	Read Only
I:<slot>.<word>/<bit>	<b>Boolean</b>	Read Only

### Ranges

PLC Model	Min. Slot	Max. Slot	Max. Word
MicroLogix	N/A	N/A	2047
SLC 500 Fixed I/O	N/A	N/A	1
SLC 500 Modular I/O	1	30	*
PLC-5 Series	N/A	N/A	277 (octal)

\*The number of Input or Output words available for each I/O module can be found in the [SLC 500 Modular I/O Selection Guide](#).

### Examples

MicroLogix	Description
I:0	Word 0
I/2	Bit 2
I:1/5	Bit 5 word 1

SLC 500 Fixed I/O	Description
I:0	Word 0
I:1	Word 1
I/16	bit 16
I:1/0	Bit 0 word 1 (same as I/16)

PLC5*	Description
I:0	Word 0
I:10	Word 8 (10 octal = 8 decimal)
I/20	Bit 16 (20 octal = 16 decimal)
I:1/0	Bit 0 word 1 (same as I/20)

\*Addresses are in Octal.

SLC 500 Modular I/O	Description
I:1	Word 0 slot 1
I:1.0	Word 0 slot 1 (same as I:1)
I:12	Word 0 slot 12
I:12.2	Word 2 slot 12
I:4.0/0	Bit 0 word 0 slot 4
I:4/0	Bit 0 slot 4 (same as I:4.0/0)
I:4.2/0	Bit 0 word 2 slot 4
I:4/32	Bit 32 slot 4 (same as I:4.2/0)

## Status Files

To access status files, specify a word and an optional bit in the word. The default data types are shown in **bold**.

Syntax	Data Type	Access
S:<word>	Short, <b>Word</b> , BCD, DWord, Long, LBCD	Read/Write
S:<word> [rows][cols]	Short, <b>Word</b> , BCD, DWord, Long, LBCD (array type)	Read/Write
S:<word> [cols]	Short, <b>Word</b> , BCD, DWord, Long, LBCD (array type)	Read/Write
S:<word>/<bit>	<b>Boolean</b>	Read/Write
S/bit	<b>Boolean</b>	Read/Write

The number of array elements (in bytes) cannot exceed the block request size specified. This means that the array size cannot exceed 16 words given a block request size of 32 bytes.

## Ranges

PLC Model	Max. Word
MicroLogix	999
SLC 500 Fixed I/O	96
SLC 500 Modular I/O	999
PLC-5 Series	999

The maximum word location is one less when accessing as a 32-bit data type (such as Long, DWord, or Long BCD).

## Examples

Example	Description
S:0	Word 0
S/26	Bit 26
S:4/15	Bit 15 word 4
S:10 [16]	16 element array starting at word 10
S:0 [4] [8]	4 by 8 element array starting at word 0

## Binary Files

To access binary files, specify a file number, a word and optional bit in the word. The default data types are shown in **bold**.

Syntax	Data Type	Access
B<file>:<word>	Short, <b>Word</b> , BCD, DWord, Long, LBCD	Read/Write
B<file>:<word> [rows][cols]	Short, <b>Word</b> , BCD, DWord, Long, LBCD (array type)	Read/Write
B<file>:<word> [cols]	Short, <b>Word</b> , BCD, DWord, Long, LBCD (array type)	Read/Write
B<file>:<word>/<bit>	<b>Boolean</b>	Read/Write
B<file>/bit	<b>Boolean</b>	Read/Write

The number of array elements (in bytes) cannot exceed the block request size specified. This means that array size cannot exceed 16 words given a block request size of 32 bytes.

## Ranges

PLC Model	File Number	Max. Word
MicroLogix	3, 9-999	999
SLC 500 Fixed I/O	3, 9-255	255
SLC 500 Modular I/O	3, 9-999	999
PLC-5 Series	3-999	1999

The maximum word location is one less when accessing as a 32-bit data type (such as Long, DWord, or Long BCD).

### Examples

Example	Description
B3:0	Word 0
B3/26	Bit 26
B12:4/15	Bit 15 word 4
B3:10 [20]	20 element array starting at word 10
B15:0 [6] [6]	6 by 6 element array starting at word 0

### Timer Files

Timer files are a structured type whose data is accessed by specifying a file number, an element and a field. The default data types are shown in **bold**.

Syntax	Data Type	Access
T<file>:<element>.<field>	Depends on field	Depends on field

The following fields are allowed for each element. For the meaning of each field, refer to the PLC's documentation.

Element Field	Data Type	Access
ACC	<b>Short, Word</b>	Read/Write
PRE	<b>Short, Word</b>	Read/Write
DN	<b>Boolean</b>	Read Only
TT	<b>Boolean</b>	Read Only
EN	<b>Boolean</b>	Read Only

### Ranges

PLC Model	File Number	Max. Element
MicroLogix	4, 9-999	999
SLC 500 Fixed I/O	4, 9-255	255
SLC 500 Modular I/O	4, 9-999	999
PLC-5 Series	3-999	1999

### Examples

Example	Description
T4:0.ACC	Accumulator of timer 0 file 4
T4:10.DN	Done bit of timer 10 file 4
T15:0.PRE	Preset of timer 0 file 15

### Counter Files

Counter files are a structured type whose data is accessed by specifying a file number, an element, and a field. The default data types are shown in **bold**.

Syntax	Data Type	Access
C<file>:<element>.<field>	Depends on field	Depends on field

The following fields are allowed for each element. For the meaning of each field, refer to the PLC's documentation.

Element Field	Data Type	Access
ACC	<b>Word</b> , Short	Read/Write
PRE	<b>Word</b> , Short	Read/Write
UA	<b>Boolean</b>	Read Only
UN	<b>Boolean</b>	Read Only
OV	<b>Boolean</b>	Read Only
DN	<b>Boolean</b>	Read Only
CD	<b>Boolean</b>	Read Only
CU	<b>Boolean</b>	Read Only

### Ranges

PLC Model	File Number	Max. Element
MicroLogix	5, 9-999	999
SLC 500 Fixed I/O	5, 9-255	255
SLC 500 Modular I/O	5, 9-999	999
PLC-5 Series	3-999	1999

### Examples

Example	Description
C5:0.ACC	Accumulator of counter 0 file 5
C5:10.DN	Done bit of counter 10 file 5
C15:0.PRE	Preset of counter 0 file 15

### Control Files

Control files are a structured type whose data is accessed by specifying a file number, an element, and a field. The default data types are shown in **bold**.

Syntax	Data Type	Access
R<file>:<element>.<field>	Depends on field	Depends on field

The following fields are allowed for each element. For the meaning of each field, refer to the PLC documentation.

Element Field	Data Type	Access
LEN	<b>Word</b> , Short	Read/Write
POS	<b>Word</b> , Short	Read/Write
FD	<b>Boolean</b>	Read Only
IN	<b>Boolean</b>	Read Only
UL	<b>Boolean</b>	Read Only
ER	<b>Boolean</b>	Read Only
EM	<b>Boolean</b>	Read Only
DN	<b>Boolean</b>	Read Only
EU	<b>Boolean</b>	Read Only
EN	<b>Boolean</b>	Read Only

## Ranges

PLC Model	File Number	Max. Element
MicroLogix	6, 9-999	999
SLC 500 Fixed I/O	6, 9-255	255
SLC 500 Modular I/O	6, 9-999	999
PLC-5 Series	3-999	1999

## Examples

Example	Description
R6:0.LEN	Length field of control 0 file 6
R6:10.DN	Done bit of control 10 file 6
R15:18.POS	Position field of control 18 file 15

## Integer Files

To access integer files, specify a file number, a word, and an optional bit in the word. The default data types are shown in **bold**.

Syntax	Data Type	Access
N<file>:<word>	Short, <b>Word</b> , BCD, DWord, Long, LBCD	Read/Write
N<file>:<word> [rows][cols]	Short, <b>Word</b> , BCD, DWord, Long, LBCD (array type)	Read/Write
N<file>:<word> [cols]	Short, <b>Word</b> , BCD, DWord, Long, LBCD (array type)	Read/Write
N<file>:<word>/<bit>	<b>Boolean</b>	Read/Write
N<file>/bit	<b>Boolean</b>	Read/Write

The number of array elements (in bytes) cannot exceed the block request size specified. This means that array size cannot exceed 16 words given a block request size of 32 bytes.

## Ranges

PLC Model	File Number	Max. Word
MicroLogix	7, 9-999	999
SLC 500 Fixed I/O	7, 9-255	255
SLC 500 Modular I/O	7, 9-999	999
PLC-5 Series	3-999	1999

The maximum word location is one less when accessing as a 32-bit data type (such as Long, DWord, or Long BCD).

## Examples

Example	Description
N7:0	Word 0
N7/26	Bit 26
N12:4/15	Bit 15 word 4
N7:10 [8]	8 element array starting at word 10
N15:0 [4] [5]	4 by 5 element array starting at word 0

## Float Files

To access float files, specify a file number and an element. The default data types are shown in **bold**.

Syntax	Data Type	Access
F<file>:<element>	<b>Float</b>	Read/Write
F<file>:<element> [rows][cols]	<b>Float</b> (array type)	Read/Write
F<file>:<element> [cols]	<b>Float</b> (array type)	Read/Write

The number of array elements (in bytes) cannot exceed the block request size specified. This means that array size cannot exceed 8 floats given a block request size of 32 bytes.

## Ranges

PLC Model	File Number	Max. Word
MicroLogix	8-999	999
SLC 500 Fixed I/O	N/A	N/A
SLC 500 Modular I/O	8-999	999
PLC-5 Series	3-999	1999

## Examples

Example	Description
F8:0	Float 0
F8:10 [16]	16 element array starting at word 10
F15:0 [4] [4]	16 element array starting at word 0

## ASCII Files

To access ASCII file data, specify a file number and a character location. The default data types are shown in **bold**.

Syntax	Data Type	Access
A<file>:<char>	<b>Char, Byte*</b>	Read/Write
A<file>:<char> [rows][cols]	<b>Char, Byte*</b>	Read/Write
A<file>:<char> [cols]	<b>Char, Byte*</b>	Read/Write
A<file>:<word offset>/length	<b>String**</b>	Read/Write

\*The number of array elements cannot exceed the block request size specified. Internally, the PLC packs two characters per word in the file, with the high byte containing the first character and the low byte containing the second character. The PLC programming software allows access at the word level or two-character level. The Allen-Bradley ControlLogix Ethernet Driver allows accessing to the character level.

Using the programming software, "A10:0 = AB," would result in 'A' being stored in the high byte of A10:0 and 'B' being stored in the low byte. Using the Allen-Bradley ControlLogix Ethernet Driver, two assignments would be made: "A10:0 = A" and "A10:1 = B." This would result in the same data being stored in the PLC memory.

\*\*Referencing this file as string data allows access to data at word boundaries like the programming software. The length can be up to 232 characters. If a string that is sent to the device is smaller in length than the length specified by the address, the driver null terminates the string before sending it down to the controller.

## Ranges

PLC Model	File Number	Max. Character
MicroLogix	3-255	511
SLC 500 Fixed I/O	N/A	N/A
SLC 500 Modular I/O	9-999	1999

PLC Model	File Number	Max. Character
PLC-5 Series	3-999	1999

● **Note:** Not all MicroLogix and SLC 500 PLC devices support ASCII file types. For more information, refer to the PLC's documentation.

### Examples

Example	Description
A9:0	character 0 (high byte of word 0)
A27:10 [80]	80 character array starting at character 10
A15:0 [4] [16]	4 by 16 character array starting at character 0
A62:0/32	32 character string starting at word offset 0

### String Files

To access string files, specify a file number and an element. Strings are 82 character null terminated arrays. The driver places the null terminator based on the string length returned by the PLC. The default data types are shown in **bold**.

● **Note:** Arrays are not supported for string files.

Syntax	Data Type	Access
ST<file>:<element>.<field>	<b>String</b>	Read/Write

### Ranges

PLC Model	File Number	Max. Word
MicroLogix	9-999	999
SLC 500 Fixed I/O	N/A	N/A
SLC 500 Modular I/O	9-999	999
PLC-5 Series	3-999	999

### Examples

Example	Description
ST9:0	String 0
ST18:10	String 10

### BCD Files

To access BCD files, specify a file number and a word. The default data types are shown in **bold**.

#### PLC-5 Syntax

Syntax	Data Type	Access
D<file>:<word>	<b>BCD, LBCD</b>	Read/Write
D<file>:<word> [rows][cols]	<b>BCD, LBCD (array type)</b>	Read/Write
D<file>:<word> [cols]	<b>BCD, LBCD (array type)</b>	Read/Write

The number of array elements (in bytes) cannot exceed the block request size specified. This means that array size cannot exceed 16 BCD, given a block request size of 32 bytes.

### Ranges

PLC Model	File Number	Max. Word
MicroLogix	N/A	N/A

PLC Model	File Number	Max. Word
SLC 500 Fixed I/O	N/A	N/A
SLC 500 Modular I/O	N/A	N/A
PLC-5 Series	3-999	999

### Examples

Example	Description
D9:0	Word 0
D27:10 [16]	16 element array starting at Word 10
D15:0 [4][8]	32 element array starting at Word 0

### Long Files

To access long integer files, specify a file number and an element. The default data types are shown in **bold**.

Syntax	Data Type	Access
L<file>:<DWord>	Long, <b>DWord</b> , LBCD	Read/Write
L<file>:<DWord> [rows][cols]	Long, <b>DWord</b> , LBCD (array type)	Read/Write
L<file>:<DWord> [cols]	Long, <b>DWord</b> , LBCD (array type)	Read/Write

The number of array elements (in bytes) cannot exceed the block request size specified. This means that array size cannot exceed 8 longs given a block request size of 32 bytes.

### Ranges

PLC Model	File Number	Max. Word
MicroLogix	9-999	999
SLC 500 Fixed I/O	N/A	N/A
SLC 500 Modular I/O	N/A	N/A
PLC-5 Series	N/A	N/A

### Examples

Example	Description
L9:0	word 0
L9:10 [8]	8 element array starting at word 10
L15:0 [4] [5]	4 by 5 element array starting at word 0

### MicroLogix PID Files

PID files are a structured type whose data is accessed by specifying a file number, an element, and a field. The default data types are shown in **bold**.

Syntax	Data Type	Access
PD<file>:<element>.<field>	Depends on field	Depends on field

The following fields are allowed for each element. For the meaning of each field, refer to the PLC's documentation for the meaning of each field.

Element Field	Data Type	Access
SPS	<b>Word</b> , Short	Read/Write
KC	<b>Word</b> , Short	Read/Write
TI	<b>Word</b> , Short	Read/Write

Element Field	Data Type	Access
TD	Word, Short	Read/Write
MAXS	Word, Short	Read/Write
MINS	Word, Short	Read/Write
ZCD	Word, Short	Read/Write
CVH	Word, Short	Read/Write
CVL	Word, Short	Read/Write
LUT	Word, Short	Read/Write
SPV	Word, Short	Read/Write
CVP	Word, Short	Read/Write
TM	Boolean	Read/Write
AM	Boolean	Read/Write
CM	Boolean	Read/Write
OL	Boolean	Read/Write
RG	Boolean	Read/Write
SC	Boolean	Read/Write
TF	Boolean	Read/Write
DA	Boolean	Read/Write
DB	Boolean	Read/Write
UL	Boolean	Read/Write
LL	Boolean	Read/Write
SP	Boolean	Read/Write
PV	Boolean	Read/Write
DN	Boolean	Read/Write
EN	Boolean	Read/Write

### Ranges

PLC Model	File Number	Max. Element
MicroLogix	3-255	255
All SLC	N/A	N/A
PLC-5	<a href="#">PID Files</a>	<a href="#">PID Files</a>

### Examples

Example	Description
PD14:0.KC	Proportional gain of PD 0 file 14
PD18:6.EN	PID enable bit of PD 6 file 18

### PID Files

PID files are a structured type whose data is accessed by specifying a file number, an element, and a field. The default data types are shown in **bold**.

### PLC-5 Syntax

Syntax	Data Type	Access
PD<file>:<element>.<field>	Depends on field	Depends on field

The following fields are allowed for each element. For the meaning of each field, refer to the PLC's documentation.

Element Field	Data Type	Access
SP	Real	Read/Write
KP	Real	Read/Write
KI	Real	Read/Write
KD	Real	Read/Write
BIAS	Real	Read/Write
MAXS	Real	Read/Write
MINS	Real	Read/Write
DB	Real	Read/Write
SO	Real	Read/Write
MAXO	Real	Read/Write
MINO	Real	Read/Write
UPD	Real	Read/Write
PV	Real	Read/Write
ERR	Real	Read/Write
OUT	Real	Read/Write
PVH	Real	Read/Write
PVL	Real	Read/Write
DVP	Real	Read/Write
DVN	Real	Read/Write
PVDB	Real	Read/Write
DVDB	Real	Read/Write
MAXI	Real	Read/Write
MINI	Real	Read/Write
TIE	Real	Read/Write
FILE	Word, Short	Read/Write
ELEM	Word, Short	Read/Write
EN	Boolean	Read/Write
CT	Boolean	Read/Write
CL	Boolean	Read/Write
PVT	Boolean	Read/Write
DO	Boolean	Read/Write
SWM	Boolean	Read/Write
CA	Boolean	Read/Write
MO	Boolean	Read/Write
PE,	Boolean	Read/Write
INI	Boolean	Read/Write
SPOR	Boolean	Read/Write
OLL	Boolean	Read/Write
OLH	Boolean	Read/Write
EWD	Boolean	Read/Write
DVNA	Boolean	Read/Write
DVHA	Boolean	Read/Write
PVLA	Boolean	Read/Write
PVHA	Boolean	Read/Write

## Ranges

PLC Model	File Number	Max. Element
MicroLogix	N/A	N/A
SLC 500 Fixed I/O	N/A	N/A
SLC 500 Modular I/O	N/A	N/A
PLC-5 Series	3-999	999

### Examples

Example	Description
PD14:0.SP	Set point field of PD 0 file 14
PD18:6.EN	Status enable bit of PD 6 file 18

### MicroLogix Message Files

Message files are a structured type whose data is accessed by specifying a file number, an element, and a field. The default data types are shown in **bold**.

Syntax	Data Type	Access
MG<file>:<element>.<field>	Depends on field	Depends on field

The following fields are allowed for each element. For the meaning of each field, refer to the PLC's documentation.

Element Field	Data Type	Access
IA	<b>Word, Short</b>	Read/Write
RBL	<b>Word, Short</b>	Read/Write
LBN	<b>Word, Short</b>	Read/Write
RBN	<b>Word, Short</b>	Read/Write
CHN	<b>Word, Short</b>	Read/Write
NOD	<b>Word, Short</b>	Read/Write
MTO	<b>Word, Short</b>	Read/Write
NB	<b>Word, Short</b>	Read/Write
TFT	<b>Word, Short</b>	Read/Write
TFN	<b>Word, Short</b>	Read/Write
ELE	<b>Word, Short</b>	Read/Write
SEL	<b>Word, Short</b>	Read/Write
TO	<b>Boolean</b>	Read/Write
CO	<b>Boolean</b>	Read/Write
EN	<b>Boolean</b>	Read/Write
RN	<b>Boolean</b>	Read/Write
EW	<b>Boolean</b>	Read/Write
ER	<b>Boolean</b>	Read/Write
DN	<b>Boolean</b>	Read/Write
ST	<b>Boolean</b>	Read/Write
BK	<b>Boolean</b>	Read/Write

### Ranges

PLC Model	File Number	Max. Element
MicroLogix	3-255	255
All SLC	N/A	N/A
PLC5	<a href="#">Message Files</a>	<a href="#">Message Files</a>

## Examples

Example	Description
MG14:0.TO	Time out bit for MSG element 0 in data file 14
MG18:6.CO	Continue bit for MSG element 6 in data file 18

## Message Files

Message files are a structured type whose data is accessed by specifying a file number, an element, and a field. The default data types are shown in **bold**.

### PLC-5 Syntax

Syntax	Data Type	Access
MG<file>:<element>.<field>	Depends on field	Depends on field

The following fields are allowed for each element. For the meaning of each field, refer to the PLC's documentation.

Element Field	Data Type	Access
ERR	<b>Short</b> , Word	Read/Write
RLEN	<b>Short</b> , Word	Read/Write
DLEN	<b>Short</b> , Word	Read/Write
EN	<b>Boolean</b>	Read/Write
ST	<b>Boolean</b>	Read/Write
DN	<b>Boolean</b>	Read/Write
ER	<b>Boolean</b>	Read/Write
CO	<b>Boolean</b>	Read/Write
EW	<b>Boolean</b>	Read/Write
NR	<b>Boolean</b>	Read/Write
TO	<b>Boolean</b>	Read/Write

## Ranges

PLC Model	File Number	Max. Element
MicroLogix	N/A	N/A
SLC 500 Fixed I/O	N/A	N/A
SLC 500 Modular I/O	N/A	N/A
PLC-5 Series	3-999	999

## Examples

Example	Description
MG14:0.RLEN	Requested length field of MG 0 file 14
MG18:6.CO	Continue bit of MG 6 file 18

## Block Transfer Files

Block transfer files are a structured type whose data is accessed by specifying a file number, an element, and a field. The default data types are shown in **bold**.

### PLC-5 Syntax

Syntax	Data Type	Access
BT<file>:<element>.<field>	Depends on field	Depends on field

The following fields are allowed for each element. For more information on the meaning of each field, refer to the PLC's documentation.

Element Field	Data Type	Access
RLEN	Word, Short	Read/Write
DLEN	Word, Short	Read/Write
FILE	Word, Short	Read/Write
ELEM	Word, Short	Read/Write
RW	Boolean	Read/Write
ST	Boolean	Read/Write
DN	Boolean	Read/Write
ER	Boolean	Read/Write
CO	Boolean	Read/Write
EW	Boolean	Read/Write
NR	Boolean	Read/Write
TO	Boolean	Read/Write

### Ranges

PLC Model	File Number	Max. Element
MicroLogix	N/A	N/A
SLC 500 Fixed I/O	N/A	N/A
SLC 500 Modular I/O	N/A	N/A
PLC-5 Series	3-999	1999

### Examples

Example	Description
BT14:0.RLEN	Requested length field of BT 0 file 14
BT18:6.CO	Continue bit of BT 6 file 18

## Function Files

For information on the files supported by the ENI MicroLogix and MicroLogix 1100 device models, select a link from the list below.

[High-Speed Counter File \(HSC\)](#)

[Real-Time Clock File \(RTC\)](#)

[Channel 0 Communication Status File \(CS0\)](#)

[Channel 1 Communication Status File \(CS1\)](#)

[I/O Module Status File \(IOS\)](#)

• For more information on device models and their supported files, refer to [Address Descriptions](#).

## High-Speed Counter File (HSC)

The HSC files are a structured type whose data is accessed by specifying an element and a field. The default data types are shown in **bold**.

• See Also: [ENI DF1/DH+/ControlNet Gateway Communications Parameters](#)

Syntax	Data Type	Access
HSC:<element>.<field>	Depends on field	Depends on field

The following fields are allowed for each element. For the meaning of each field, refer to the PLC's documentation.

Element Field	Default Type	Access
ACC	<b>DWord</b> , Long	Read Only
HIP	<b>DWord</b> , Long	Read/Write
LOP	<b>DWord</b> , Long	Read/Write
OVF	<b>DWord</b> , Long	Read/Write
UNF	<b>DWord</b> , Long	Read/Write
PFN	<b>Word</b> , Short	Read Only
ER	<b>Word</b> , Short	Read Only
MOD	<b>Word</b> , Short	Read Only
OMB	<b>Word</b> , Short	Read Only
HPO	<b>Word</b> , Short	Read/Write
LPO	<b>Word</b> , Short	Read/Write
UIX	<b>Boolean</b>	Read Only
UIP	<b>Boolean</b>	Read Only
AS	<b>Boolean</b>	Read Only
ED	<b>Boolean</b>	Read Only
SP	<b>Boolean</b>	Read Only
LPR	<b>Boolean</b>	Read Only
HPR	<b>Boolean</b>	Read Only
DIR	<b>Boolean</b>	Read Only
CD	<b>Boolean</b>	Read Only
CU	<b>Boolean</b>	Read Only
UIE	<b>Boolean</b>	Read/Write
UIL	<b>Boolean</b>	Read/Write
FE	<b>Boolean</b>	Read/Write
CE	<b>Boolean</b>	Read/Write

Element Field	Default Type	Access
LPM	<b>Boolean</b>	Read/Write
HPM	<b>Boolean</b>	Read/Write
UFM	<b>Boolean</b>	Read/Write
OFM	<b>Boolean</b>	Read/Write
LPI	<b>Boolean</b>	Read/Write
HPI	<b>Boolean</b>	Read/Write
UFI	<b>Boolean</b>	Read/Write
OFI	<b>Boolean</b>	Read/Write
UF	<b>Boolean</b>	Read/Write
OF	<b>Boolean</b>	Read/Write
MD	<b>Boolean</b>	Read/Write

### Ranges

PLC Model	File Number	Max. Element
MicroLogix	N/A	254
All SLC	N/A	N/A
PLC5	N/A	N/A

### Examples

Example	Description
HSC:0.OMB	Output mask setting for high-speed counter 0
HSC:1.ED	Error detected indicator for high-speed counter 1

### Real-Time Clock File (RTC)

The RTC files are a structured type whose data is accessed by specifying an element and a field. The default data types are shown in **bold**.

 **See Also:** [ENI DF1/DH+/ControlNet Gateway Communications Parameters](#)

Syntax	Data Type	Access
RTC:<element>.<field>	Depends on field	Depends on field

The following fields are allowed for each element. For the meaning of each field, refer to the PLC's documentation.

Element Field	Data Type	Access
YR	<b>Word</b> , Short	Read/Write
MON	<b>Word</b> , Short	Read/Write
DAY	<b>Word</b> , Short	Read/Write
HR	<b>Word</b> , Short	Read/Write
MIN	<b>Word</b> , Short	Read/Write
SEC	<b>Word</b> , Short	Read/Write
DOW	<b>Word</b> , Short	Read/Write
DS	<b>Boolean</b>	Read Only
BL	<b>Boolean</b>	Read Only
_SET (for block writes)	<b>Boolean</b>	Read/Write

### Ranges

PLC Model	File Number	Max. Element
MicroLogix	N/A	254
All SLC	N/A	N/A
PLC5	N/A	N/A

### Examples

Example	Description
RTC:0.YR	Year setting for real-time clock 0.
RTC:0.BL	Battery low indicator for real-time clock 0.

### Channel 0 Communication Status File (CS0)

To access the communication status file for channel 0, specify a word (and optionally a bit in the word). The default data types are shown in **bold**.

• See Also: [ENI DF1/DH+/ControlNet Gateway Communications Parameters](#)

Syntax	Data Type	Access
CS0:<word>	Short, <b>Word</b> , BCD, DWord, Long, LBCD	Depends on <word> and <bit>
CS0:<word>/<bit>	<b>Boolean</b>	Depends on <word> and <bit>
CS0/bit	<b>Boolean</b>	Depends on <word> and <bit>

### Ranges

PLC Model	File Number	Max. Element
MicroLogix	N/A	254
All SLC	N/A	N/A
PLC5	N/A	N/A

### Examples

Example	Description
CS0:0	Word 0
CS0:4/2	Bit 2 word 4 = MCP

• For more information on CS0 words/bit meanings, refer to the Rockwell documentation.

### Channel 1 Communication Status File (CS1)

To access the communication status file for channel 1, specify a word (and optionally a bit in the word). The default data types are shown in **bold**.

• See Also: [ENI DF1/DH+/ControlNet Gateway Communications Parameters](#)

Syntax	Data Type	Access
CS1:<word>	Short, <b>Word</b> , BCD, DWord, Long, LBCD	Depends on <word> and <bit>
CS1:<word>/<bit>	<b>Boolean</b>	Depends on <word> and <bit>
CS1/bit	<b>Boolean</b>	Depends on <word> and <bit>

### Ranges

PLC Model	File Number	Max. Element
MicroLogix	N/A	254
All SLC	N/A	N/A
PLC5	N/A	N/A

### Examples

Example	Description
CS1:0	Word 0
CS1:4/2	Bit 2 word 4 = MCP

• For more information on CS1 words/bit meanings, refer to the Rockwell documentation.

### I/O Module Status File (IOS)

To access an I/O module status file, specify a word and optionally a bit. The default data types are shown in **bold**.

• See Also: [ENI DF1/DH+/ControlNet Gateway Communications Parameters](#)

Syntax	Data Type	Access
IOS:<word>	Short, <b>Word</b> , BCD, DWord, Long, LBCD	Depends on <word> and <bit>
IOS:<word>/<bit>	<b>Boolean</b>	Depends on <word> and <bit>
IOS/bit	<b>Boolean</b>	Depends on <word> and <bit>

### Ranges

PLC Model	File Number	Max. Element
MicroLogix	N/A	254
All SLC	N/A	N/A
PLC5	N/A	N/A

### Examples

Example	Description
IOS:0	Word 0
IOS:4/2	Bit 2 word 4

• For a listing of 1769 expansion I/O status codes, refer to the manufacturer's instruction manual.

## Error Codes

The following sections define error codes that may be encountered in the server's Event Log. For more information on a specific error code type, select a link from the list below.

### [Encapsulation Error Codes](#)

#### [CIP Error Codes](#)

## Encapsulation Error Codes

The following error codes are in hexadecimal.

Error Code	Description
0001	Command not handled
0002	Memory not available for command
0003	Poorly formed or incomplete data
0064	Invalid session ID
0065	Invalid length in header
0069	Requested protocol version not supported
0070	Invalid target ID

## CIP Error Codes

The following error codes are in hexadecimal.

Error Code	Log Code	Description
0001	0x01	Connection Failure*
0002	0x02	Insufficient resources
0003	0x03	Value invalid
0004	0x04	IOI could not be deciphered or tag does not exist ● <b>Note:</b> This error may also occur if the address is valid but the security permissions do not allow client access."
0005	0x05	Unknown destination
0006	0x06	Data requested would not fit in response packet
0007	0x07	Loss of connection
0008	0x08	Unsupported service
0009	0x09	Error in data segment or invalid attribute value
000A	0x0A	Attribute list error
000B	0x0B	State already exists
000C	0x0C	Object model conflict
000D	0x0D	Object already exists
000E	0x0E	Attribute not settable
000F	0x0F	Permission denied
0010	0x10	Device state conflict
0011	0x11	Reply does not fit
0012	0x12	Fragment primitive
0013	0x13	Insufficient command data / parameters specified to execute service
0014	0x14	Attribute not supported
0015	0x15	Too much data specified
001A	0x1A	Bridge request too large
001B	0x1B	Bridge response too large

Error Code	Log Code	Description
001C	0x1C	Attribute list shortage
001D	0x1D	Invalid attribute list
001E	0x1E	Embedded service error
001F	0x1F	Failure during connection**
0022	0x22	Invalid reply received
0025	0x25	Key segment error
0026	0x26	Number of IOI words specified does not match IOI word count
0027	0x27	Unexpected attribute in list

• **\*See Also:** [0x0001 Extended Error Codes](#)

• **\*\*See Also:** [0x001F Extended Error Codes](#)

### Logix5000-Specific (1756-L1) Error Codes

The following error codes are in hexadecimal.

Error Code	Description
00FF	General Error*

• **\*See Also:** [0x00FF Extended Error Codes](#)

• **See Also:** For unlisted error codes, refer to the Rockwell documentation.

### 0x0001 Extended Error Codes

The following error codes are in hexadecimal.

Error Code	Description
0100	Connection in use
0103	Transport not supported
0106	Ownership conflict
0107	Connection not found
0108	Invalid connection type
0109	Invalid connection size
0110	Module not configured
0111	EPR not supported
0114	Wrong module
0115	Wrong device type
0116	Wrong revision
0118	Invalid configuration format
011A	Application out of connections
0203	Connection timeout
0204	Unconnected message timeout
0205	Unconnected send parameter error
0206	Message too large
0301	No buffer memory
0302	Bandwidth not available
0303	No screeners available
0305	Signature match
0311	Port not available

Error Code	Description
0312	Link address not available
0315	Invalid segment type
0317	Connection not scheduled
0318	Link address to self is invalid

• For unlisted error codes, refer to the Rockwell documentation.

### 0x001F Extended Error Codes

The following error codes are in hexadecimal.

Error Code	Description
0203	Connection timed out

• For unlisted error codes, refer to the Rockwell documentation.

### 0x00FF Extended Error Codes

The following error codes are in hexadecimal.

Error Code	Description
2104	Address out of range
2105	Attempt to access beyond end of data object
2106	Data in use
2107	Data type is invalid or not supported

• For unlisted error codes, refer to the Rockwell documentation.

# Event Log Messages

The following information concerns messages posted to the Event Log pane in the main user interface. Consult the OPC server help on filtering and sorting the Event Log detail view. Server help contains many common messages, so should also be searched. Generally, the type of message (informational, warning) and troubleshooting information is provided whenever possible.

● **Tip:** Messages that originate from a data source (such as third-party software, including databases) are presented through the Event Log. Troubleshooting steps should include researching those messages online and in vendor documentation.

---

## The following errors occurred uploading controller project from device. Resorting to Symbolic Protocol.

---

### Error Type:

Error

### Invalid or corrupt controller project detected while synchronizing. Synchronization will be retried shortly.

---

### Error Type:

Error

### Possible Cause:

An invalid or corrupt controller project was detected during synchronization.

### Possible Solution:

No action is required. The driver attempts synchronization again after 30 seconds.

### ● Note:

Project synchronization is required for the Logical Addressing Modes.

---

## Project download detected while synchronizing. Synchronization will be retried shortly.

---

### Error Type:

Error

### Possible Cause:

A project download was attempted while the device was synchronizing with the controller project.

### Possible Solution:

No action is required. The driver attempts synchronization again after 30 seconds.

### ● Note:

Project synchronization is required for the Logical Addressing Modes.

---

## Database error. Data type for reference tag unknown. Setting alias tag data type to default. | Reference tag = '<tag>', Alias tag = '<tag>', Default data type = '<type>'.

---

### Error Type:

Error

### Possible Cause:

The data type of the "Alias For" tag referenced in the alias tag declaration could not be found in the tag import file. This data type is necessary to generate the alias tag correctly.

### Possible Solution:

The Alias tag assumes the data type specified as the Default Type.

**Note:**

In RSLogix5000, there is an "Alias For" column in the tag view under the Edit Tags tab where the reference to the tag, structure tag member, or bit that the alias tag will represent is entered.

**See Also:**

Logix Options

---

**Database error. Member data type not found in tag import file. Setting data type to default. | Member data type = '<type>', UDT = '<type>', Default data type '<type>'.**

---

**Error Type:**

Error

**Possible Cause:**

The definition of the data type for a member in the user-defined type could not be found in the tag import file. The member takes the default type specified in the Device Properties.

**Possible Solution:**

Verify or correct the definition of the user-defined data types for the specified tags and retry the import.

**See Also:**

Logix Options

---

**Database error. Data type not found in tag import file. Tag not added. | Data type = '<type>', Tag name = '<tag>'.**

---

**Error Type:**

Error

**Possible Cause:**

The definition of the data type for the specified tag could not be found in the tag import file. Tag is not added to the database.

**Possible Solution:**

Verify or correct the definition of the data types for the specified tags and retry the import.

---

**Database error. Error occurred processing alias tag. Tag not added. | Alias tag = '<tag>'.**

---

**Error Type:**

Error

**Possible Cause:**

An internal error occurred processing alias tag. Alias tag could not be generated.

**Possible Solution:**

Verify or correct the definition of the data types for the specified tags and retry the import.

---

**Database error. Encapsulation error occurred during register session request. | Encapsulation error = <code>.**

---

**Error Type:**

Error

**Possible Cause:**

The device returned an error within the Encapsulation portion of the Ethernet/IP packet during a request. All reads and writes within the request failed.

**Possible Solution:**

The driver attempts to recover from such an error. If the problem persists, contact Technical Support. This excludes error 0x02, which is device-related, not driver-related.

**See Also:**

Encapsulation Error Codes

---

**Database error. Framing error occurred during register session request.**

---

**Error Type:**

Error

---

**Database error. Encapsulation error occurred during fwd. open request. | Encapsulation error = <code>.**

---

**Error Type:**

Error

---

**Database error. Framing error occurred during forward open request.**

---

**Error Type:**

Error

---

**Database error. Error occurred during forward open request. | CIP error = <code>, Extended error = <code>.**

---

**Error Type:**

Error

---

**Database error. Encapsulation error occurred while uploading project information. | Encapsulation error = <code>.**

---

**Error Type:**

Error

**Possible Cause:**

The device returned an error within the encapsulation portion of the Ethernet/IP packet while uploading the controller project.

**Possible Solution:**

The solution depends on the error code returned. If the problem persists, contact Technical Support.

**Note:**

A project upload is required for the Logical Addressing Modes.

**See Also:**

Encapsulation Error Codes

---

**Database error. Error occurred while uploading project information. | CIP error = <code>, Extended error = <code>.**

---

**Error Type:**

Error

**Possible Cause:**

The device returned an error within the CIP portion of the Ethernet/IP packet while uploading the controller project.

**Possible Solution:**

The solution depends on the error code returned. If the problem persists, contact Technical Support.

**Note:**

A project upload is required for the Logical Addressing Modes.

**See Also:**

CIP Error Codes

---

**Database error. Framing error occurred while uploading project information.**

**Error Type:**

Error

**Possible Cause:**

1. The packets are misaligned (due to connection/disconnection between the PC and device).
2. There is bad cabling connecting the device that is causing noise.

**Possible Solution:**

1. Place the device on a less noisy network.
2. Increase the request timeout and/or attempts.
3. Restart the server and try again.

**Note:**

A project upload is required for the Logical Addressing Modes.

---

**Database error. Internal error occurred.**

**Error Type:**

Error

---

**Database error. Encapsulation error occurred while uploading program information. | Program name = '<name>', Encapsulation error = <code>.**

**Error Type:**

Error

**Possible Cause:**

The device returned an error within the encapsulation portion of the Ethernet/IP packet while uploading the controller project.

**Possible Solution:**

The solution depends on the error code returned. If the problem persists, contact Technical Support.

**Note:**

A project upload is required for the Logical Addressing Modes.

**See Also:**

Encapsulation Error Codes

---

**Database error. Error occurred while uploading program information. | Program name = '<name>', CIP error = <code>, Extended error = <code>.**

**Error Type:**

Error

**Possible Cause:**

The device returned an error within the CIP portion of the Ethernet/IP packet while uploading the controller project.

**Possible Solution:**

The solution depends on the error code that is returned. If the problem persists, contact Technical Support.

**Note:**

A project upload is required for the Logical Addressing Modes.

**See Also:**

CIP Error Codes

---

**Database error. Framing error occurred while uploading program information. | Program name = '<name>'.**

---

**Error Type:**

Error

**Possible Cause:**

1. The packets are misaligned (due to connection/disconnection between the PC and device).
2. There is bad cabling connecting the device that is causing noise.

**Possible Solution:**

1. Place the device on a less noisy network.
2. Increase the request timeout and/or attempts.
3. Restart the server and try again.

**Note:**

A project upload is required for the Logical Addressing Modes.

---

**Database error. Unable to resolve CIP data type for tag. Setting to default type. | CIP data type = <type>, Tag name = '<tag>', Default data type = '<type>'.**

---

**Error Type:**

Error

**Possible Cause:**

1. The CIP data type in the import file is unknown.
2. The import file may contain an error.

**Possible Solution:**

Resolve any errors in RSLogix, then retry the tag export process to produce a new tag import file.

**See Also:**

Preparing for Automatic Tag Database Generation

---

**Encapsulation error occurred while uploading project information. | Encapsulation error = <code>.**

---

**Error Type:**

Error

**Possible Cause:**

The device returned an error within the encapsulation portion of the Ethernet/IP packet while uploading the controller project.

**Possible Solution:**

The solution depends on the error code returned. If the problem persists, contact Technical Support.

**Note:**

A project upload is required for the Logical Addressing Modes.

**See Also:**

Encapsulation Error Codes

---

**Error occurred while uploading project information. | CIP error = <code>, Extended error = <code>.**

---

**Error Type:**

Error

**Possible Cause:**

The device returned an error within the CIP portion of the Ethernet/IP packet while uploading the controller project.

**Possible Solution:**

The solution depends on the error code that is returned. If the problem persists, contact Technical Support.

**Note:**

A project upload is required for the Logical Addressing Modes.

**See Also:**

CIP Error Codes

---

**Framing error occurred while uploading project information.**

---

**Error Type:**

Error

**Possible Cause:**

1. The packets are misaligned (due to connection/disconnection between the PC and device).
2. There is bad cabling connecting the device that is causing noise.

**Possible Solution:**

1. Place the device on a less noisy network.
2. Increase the request timeout and/or attempts.
3. Restart the server and try again.

**Note:**

A project upload is required for the Logical Addressing Modes.

---

**Encapsulation error occurred while uploading program information. | Program name = '<name>', Encapsulation error = <code>.**

---

**Error Type:**

Error

---

**Error occurred while uploading program information. | Program name = '<name>', CIP error = <code>, Extended error = <code>.**

---

**Error Type:**

Error

---

**Framing error occurred while uploading program information. | Program name = '<name>'.**

---

**Error Type:**

Error

---

**Encapsulation error occurred while uploading controller program information. Encapsulation error = <code>.**

---

**Error Type:**

Error

---

**Error occurred while uploading controller program information. CIP error = <code>, Extended error = <code>.**

---

**Error Type:**

Error

---

**Framing error occurred while uploading controller program information.**

---

**Error Type:**

Error

---

**CIP connection timed out while uploading project information.**

---

**Error Type:**

Error

**Possible Cause:**

The Inactivity Watchdog is set too low to allow the project to load.

**Possible Solution:**

Increase the Inactivity Watchdog value and try again.

---

**Database error. CIP connection timed out while uploading project information.**

---

**Error Type:**

Error

**Possible Cause:**

The Inactivity Watchdog is set too low to allow the project to load.

**Possible Solution:**

Increase the Inactivity Watchdog value and try again.

---

**Database error. No more connections available for fwd. open request.**

---

**Error Type:**

Error

---

**Error opening file for tag database import. | OS error = '<code>'.**

---

**Error Type:**

Error

---

---

**Controller not supported. | Vendor ID = <ID>, Product type = <type>, Product code = <code>, Product name = '<name>'.**

---

**Error Type:**

Warning

**Frame received from device contains errors.**

---

**Error Type:**

Warning

**Possible Cause:**

1. The packets are misaligned due to connection and/or disconnection between the PC and device.
2. There is bad cabling connecting the device that is causing noise.

**Possible Solution:**

1. Place the device on less noisy network.
2. Increase the request timeout and/or attempts.

---

**Write request failed due to a framing error. | Tag address = '<address>'.**

---

**Error Type:**

Warning

**Possible Cause:**

1. There is an incorrect request service code.
2. The driver received more or fewer bytes than expected.
3. If this error occurs frequently, there may be an issue with the cabling or device.

**Possible Solution:**

1. Increase the retry attempts to allow the driver to recover from this error.
2. Verify the cabling and device are functioning properly.

---

**Read request for tag failed due to a framing error. | Tag address = '<address>'.**

---

**Error Type:**

Warning

**Possible Cause:**

1. There is an incorrect request service code.
2. The driver received more or fewer bytes than expected.
3. If this error occurs frequently, there may be an issue with the cabling or device.

**Possible Solution:**

1. Increase the retry attempts to allow the driver to recover from this error.
2. Verify the cabling and device are functioning properly.

**Block read request failed due to a framing error. | Block size = <number> (elements), Block start address = '<address>'.**

---

**Error Type:**

Warning

**Possible Cause:**

1. The Ethernet connection between the device and the host PC is broken.
2. The communication parameters for the Ethernet connection are incorrect.
3. The named device may have been assigned an incorrect IP address.

**Possible Solution:**

1. Verify the cabling between the PC and the device.
2. Verify that the correct port has been specified for the named device.
3. Verify that the IP address given to the named device matches that of the actual device.

**Block read request failed due to a framing error. | Block size = <number> (bytes), Block name = '<name>'.**

---

**Error Type:**

Warning

**Possible Cause:**

1. There is an incorrect request service code.
2. The driver received more or fewer bytes than expected.
3. If this error occurs frequently, there may be an issue with the cabling or device.

**Possible Solution:**

1. Increase the retry attempts to allow the driver to recover from this error.
2. Verify the cabling and device are functioning properly.

**Unable to write to tag. | Tag address = '<address>', CIP error = <code>, Extended error = <code>.**

---

**Error Type:**

Warning

**Possible Cause:**

The device returned an error within the CIP portion of the Ethernet/IP packet during a write request for the specified tag.

**Possible Solution:**

The solution depends on the error codes returned.

**See Also:**

CIP Error Codes

**Unable to read tag. | Tag address = '<address>', CIP error = <code>, Extended error = <code>.**

---

**Error Type:**

Warning

**Possible Cause:**

The device returned an error within the CIP portion of the Ethernet/IP packet during a read request for the specified tag.

**Possible Solution:**

The solution depends on the error codes returned.

**See Also:**

CIP Error Codes

**Unable to read block. | Block size = <number> (elements), Block start address = '<address>', CIP error = <code>, Extended error = <code>.**

---

**Error Type:**

Warning

**Unable to read block. | Block size = <number> (bytes), Tag name = '<tag>', CIP error = <code>, Extended error = <code>.**

---

**Error Type:**

Warning

**Unable to write to tag. Controller tag data type unknown. | Tag address = '<address>', Data type = <type>.**

---

**Error Type:**

Warning

**Possible Cause:**

A write request for the specified tag failed because the controller tag data type is not supported.

**Possible Solution:**

Contact Technical Support so that support may be added for this type.

**See Also:**

Addressing Atomic Data Types

**Unable to read tag. Controller tag data type unknown. Tag deactivated. | Tag address = '<address>', Data type = <type>.**

---

**Error Type:**

Warning

**Possible Cause:**

A read request for the specified tag failed because the controller tag data type is not supported.

**Possible Solution:**

Contact Technical Support so that support may be added for this type.

**See Also:**

Addressing Atomic Data Types

**Unable to read block. Controller tag data type unknown. Block deactivated. | Block size = <number> (elements), Block start address = '<address>', Data type = <type>.**

---

**Error Type:**

Warning

**Possible Cause:**

A read request for the specified block failed because a controller tag data type within the block is not supported.

**Possible Solution:**

Contact Technical Support so that support may be added for this type.

**See Also:**

Addressing Atomic Data Types

**Unable to write to tag. Data type not supported. | Tag address = '<address>', Data type = '<type>'.**

---

**Error Type:**

Warning

**Possible Cause:**

A write request for the specified tag failed because the client tag data type is not supported.

**Possible Solution:**

Change the tag data type to one that is supported.

**See Also:**

Addressing Atomic Data Types

**Unable to read tag. Data type not supported. Tag deactivated. | Tag address = '<address>', Data type = '<type>'.**

---

**Error Type:**

Warning

**Possible Cause:**

A read request for the specified tag failed because the controller tag data type is not supported.

**Possible Solution:**

Contact Technical Support so that support may be added for this type.

**See Also:**

Addressing Atomic Data Types

**Unable to read block. Data type not supported. Block deactivated. | Block size = <number> (elements), Block start address = '<address>', Data type = '<type>'.**

---

**Error Type:**

Warning

**Possible Cause:**

A read request for the specified block failed because a controller tag data type within the block is not supported.

**Possible Solution:**

Contact Technical Support so that support may be added for this type.

**See Also:**

Addressing Atomic Data Types

---

**Unable to write to tag. Data type is illegal for this tag. | Tag address = '<address>', Data type = '<type>'.**

---

**Error Type:**

Warning

**Possible Cause:**

A write request for the specified tag failed because the client tag data type is illegal for the given controller tag.

**Possible Solution:**

Change the tag data type to one that is supported. For example, data type Short is illegal for a BOOL array controller tag. Changing the data type to Boolean would remedy this problem.

**See Also:**

Addressing Atomic Data Types

---

**Unable to read tag. Data type is illegal for this tag. Tag deactivated | Tag address = '<address>', Data type = '<type>'.**

---

**Error Type:**

Warning

**Possible Cause:**

A read request for the specified tag failed because the client tag data type is illegal for the given controller tag.

**Possible Solution:**

Change the tag data type to one that is supported. For example, data type Short is illegal for a BOOL array Controller tag. Changing the data type to Boolean can remedy the problem.

**See Also:**

Addressing Atomic Data Types

---

**Unable to read block. Data type is illegal for this block. Block deactivated. | Block size = <number> (elements), Block start address = '<address>', Data type = '<type>'.**

---

**Error Type:**

Warning

**Possible Cause:**

A read request for block failed because the client tag data type is illegal for the given controller tag.

**Possible Solution:**

Change the data type for tags within this block to supported types. For example, data type Short is illegal for a BOOL array Controller tag. Changing the data type to Boolean would remedy this problem.

**See Also:**

Addressing Atomic Data Types

---

**Unable to write to tag. Tag does not support multi-element arrays. | Tag address = '<address>'.**

---

**Error Type:**

Warning

**Possible Cause:**

A read request for the specified tag failed because the driver does not support multi-element array access to the given controller tag.

**Possible Solution:**

Change the tag data type or address to one that is supported.

**See Also:**

Addressing Atomic Data Types

---

**Unable to read tag. Tag does not support multi-element arrays. Tag deactivated. | Tag address = '<address>'.**

---

**Error Type:**

Warning

**Possible Cause:**

A read request for the specified tag failed because the driver does not support multi-element array access to the given controller tag.

**Possible Solution:**

Change the tag data type or address to one that is supported. In response to this error, the tag is deactivated and not processed again.

**See Also:**

Addressing Atomic Data Types

---

**Unable to read block. Block does not support multi-element arrays. Block deactivated. | Block size = <number> (elements), Block start address = '<address>'.**

---

**Error Type:**

Warning

**Possible Cause:**

A read request for tags in this block failed because the driver does not support multi-element array access to the given controller tag.

**Possible Solution:**

Change the data type or address for tags within this block to supported types. In response to this error, <count> elements of the block are deactivated and not processed again.

**See Also:**

Addressing Atomic Data Types

---

**Unable to write to tag. Native tag size mismatch. | Tag address = '<address>'.**

---

**Error Type:**

Warning

**Possible Cause:**

The Native tag's size (footprint) does not match the expected size that was determined from the project upload.

**Possible Solution:**

1. Change the Protocol Mode to Symbolic Mode and try again.
2. Contact Technical Support to report the issue.

---

**Unable to read tag. Native tag size mismatch. | Tag address = '<address>'.**

---

**Error Type:**

Warning

**Possible Cause:**

The Native tag's size (footprint) does not match the expected size determined from the project upload.

**Possible Solution:**

1. Change the Protocol Mode to Symbolic Mode and try again.
2. Contact Technical Support to report the issue.

---

**Unable to read block. Native tag size mismatch. | Block size = <number> (elements), Block start address = '<address>'.**

---

**Error Type:**

Warning

**Possible Cause:**

The block of Native tag's size (footprint) does not match the expected size determined from the project upload.

**Possible Solution:**

1. Change the Protocol Mode to Symbolic Mode and try again.
2. Contact Technical Support to report the issue.

---

**Unable to read block. Native tag size mismatch. | Block size = <number> (bytes), Block name = '<name>'.**

---

**Error Type:**

Warning

**Possible Cause:**

The block of Native tag's size (footprint) does not match the expected size determined from the project upload.

**Possible Solution:**

1. Change the Protocol Mode to Symbolic Mode and try again.
2. Contact Technical Support to report the issue.

---

**Unable to write to tag. | Tag address = '<address>'.**

---

**Error Type:**

Warning

**Possible Cause:**

1. The Ethernet connection between the device and the host PC is broken.
2. The communication parameters for the Ethernet connection are incorrect.
3. The named device may have been assigned an incorrect IP address.

**Possible Solution:**

1. Verify the cabling between the PC and the device.
2. Verify that the correct port has been specified for the named device.
3. Verify that the IP address given to the named device matches that of the actual device.

---

**Unable to read tag. Tag deactivated. | Tag address = '<address>'.**

---

**Error Type:**

Warning

**Possible Cause:**

1. The Ethernet connection between the device and the host PC is broken.
2. The communication parameters for the Ethernet connection are incorrect.
3. The named device may have been assigned an incorrect IP address.

**Possible Solution:**

1. Verify the cabling between the PC and the device.
2. Verify that the correct port has been specified for the named device.
3. Verify that the IP address given to the named device matches that of the actual device.

**Note:**

In response to this error, the tag is deactivated and not processed again.

---

**Unable to read block. Block deactivated. | Block size = <number> (elements), Block start address = '<address>'.**

---

**Error Type:**

Warning

**Possible Cause:**

1. The Ethernet connection between the device and the host PC is broken.
2. The communication parameters for the Ethernet connection are incorrect.
3. The named device may have been assigned an incorrect IP address.

**Possible Solution:**

1. Verify the cabling between the PC and the device.
2. Verify that the correct port has been specified for the named device.
3. Verify that the IP address given to the named device matches that of the actual device.

**Note:**

In response to this error, elements of the block is deactivated and not processed again.

---

**Unable to read block. Block deactivated. | Block size = <number> (bytes), Tag name = '<tag>'.**

---

**Error Type:**

Warning

**Possible Cause:**

1. The Ethernet connection between the device and the host PC is broken.
2. The communication parameters for the Ethernet connection are incorrect.
3. The named device may have been assigned an incorrect IP address.

**Possible Solution:**

1. Verify the cabling between the PC and the device.
2. Verify that the correct port has been specified for the named device.
3. Verify that the IP address given to the named device matches that of the actual device.

**Note:**

In response to this error, elements of the block is deactivated and not processed again.

**Error occurred during a request to device. | CIP error = <code>, Extended error = <code>.**

---

**Error Type:**

Warning

**Possible Cause:**

The device returned an error within the CIP portion of the Ethernet/IP packet during a request. All reads and writes within the request failed.

**Possible Solution:**

The solution depends on the error codes returned.

**See Also:**

CIP Error Codes

**Encapsulation error occurred during a request to device. | Encapsulation error = <code>.**

---

**Error Type:**

Warning

**Possible Cause:**

The device returned an error within the encapsulation portion of the Ethernet/IP packet during a request. All reads and writes within the request failed.

**Possible Solution:**

The driver attempts to recover from such an error. If the problem persists, contact Technical Support. This excludes error 0x02, which is device-related, not driver-related.

**See Also:**

Encapsulation Error Codes

**Memory could not be allocated for tag. | Tag address = '<address>'.**

---

**Error Type:**

Warning

**Possible Cause:**

Resources needed to build a tag could not be allocated. The tag is not added to the project.

**Possible Solution:**

Close any unused applications and/or increase the amount of virtual memory and try again.

**Unable to read block. Frame received contains errors. | Block size = <number> (elements), Starting address = '<address>'.**

---

**Error Type:**

Warning

**Possible Cause:**

1. There is an incorrect request service code.
2. The driver received more or fewer bytes than expected.

**Possible Solution:**

1. Increase the request attempts to allow the driver to recover from this error.
2. If this error occurs frequently, there may be an issue with the cabling or the device itself. If the error occurs frequently for a specific tag, contact Technical Support.

**Unable to read function file from device. Frame received contains errors. | Function file = '<name>'.**

---

**Error Type:**

Warning

**Unable to read block. Tags deactivated. | Block size = <number> (elements), Starting address = '<address>', DF1 status = <code>, Extended status = <code>.**

---

**Error Type:**

Warning

**Possible Cause:**

The address does not exist in the PLC.

**Possible Solution:**

Check the status and extended status codes returned by the PLC. Extended status codes may not always be returned and the error information is contained within the status code. The codes are displayed in hexadecimal.

**Note:**

Status code errors in the low nibble of the status code indicate errors found by the local node. Errors found by the local node occur when the KF module cannot see the destination PLC on the network for some reason. Status code errors in the high nibble of the status code indicate errors found by the PLC. These errors are generated when the data location is not available in the PLC or not writeable.

**See Also:**

Allen-Bradley documentation for error code definitions

**Unable to read function file from device. Tags deactivated. | Function file = '<name>', DF1 status = <code>, Extended status = <code>.**

---

**Error Type:**

Warning

**Possible Cause:**

The address does not exist in the PLC.

**Possible Solution:**

Check the status and extended status codes returned by the PLC. Extended status codes may not always be returned and the error information is contained within the status code. The codes are displayed in hexadecimal.

**Note:**

Status code errors in the low nibble of the status code indicate errors found by the local node. Errors found by the local node occur when the KF module cannot see the destination PLC on the network for some reason. Status code errors in the high nibble of the status code indicate errors found by the PLC. These errors are generated when the data location is not available in the PLC or not writeable.

**See Also:**

Allen-Bradley documentation for error code definitions

**Unable to write to address. Frame received contains errors. | Address = '<address>'.**

---

**Error Type:**

Warning

**Unable to write to function file. Frame received contains errors. | Function file = '<name>'.**

---

**Error Type:**

Warning

**Unable to read block. | Block size = <number> (elements), Starting address = '<address>', DF1 status = <code>, Extended status = <code>.**

---

**Error Type:**

Warning

**Possible Cause:**

An address does not exist in the PLC.

**Possible Solution:**

Check the status and extended status codes returned by the PLC. Extended status codes may not always be returned and the error information is contained within the status code. The codes are displayed in hexadecimal.

**Note:**

Status code errors in the low nibble of the status code indicate errors found by the local node. Errors found by the local node occur when the KF module cannot see the destination PLC on the network for some reason. Status code errors in the high nibble of the status code indicate errors found by the PLC. These errors are generated when the data location is not available in the PLC or not writeable.

**See Also:**

Allen-Bradley documentation for error code definitions

**Unable to read function file. | Function file = '<name>', DF1 status = <code>, Extended status = <code>.**

---

**Error Type:**

Warning

**Possible Cause:**

The address does not exist in the PLC.

**Possible Solution:**

Check the status and extended status codes returned by the PLC. Extended status codes may not always be returned and the error information is contained within the status code. The codes are displayed in hexadecimal.

**Note:**

Status code errors in the low nibble of the status code indicate errors found by the local node. Errors found by the local node occur when the KF module cannot see the destination PLC on the network for some reason. Status code errors in the high nibble of the status code indicate errors found by the PLC. These errors are generated when the data location is not available in the PLC or not writeable.

**See Also:**

Allen-Bradley documentation for error code definitions

---

**Unable to read block. Tags deactivated. | Block size = <number> (elements), Starting address = '<address>', DF1 status = <code>, Extended status = <code>.**

---

**Error Type:**

Warning

**Possible Cause:**

The address does not exist in the PLC.

**Possible Solution:**

Check the status and extended status codes returned by the PLC. Extended status codes may not always be returned and the error information is contained within the status code. The codes are displayed in hexadecimal.

**Note:**

Status code errors in the low nibble of the status code indicate errors found by the local node. Errors found by the local node occur when the KF module cannot see the destination PLC on the network for some reason. Status code errors in the high nibble of the status code indicate errors found by the PLC. These errors are generated when the data location is not available in the PLC or not writeable.

**See Also:**

Allen-Bradley documentation for error code definitions

---

**Unable to read function file. Tags deactivated. | Function file = '<name>', DF1 status = <code>.**

---

**Error Type:**

Warning

**Possible Cause:**

The address does not exist in the PLC.

**Possible Solution:**

Check the status and extended status codes returned by the PLC. Extended status codes may not always be returned and the error information is contained within the status code. The codes are displayed in hexadecimal.

**Note:**

Status code errors in the low nibble of the status code indicate errors found by the local node. Errors found by the local node occur when the KF module cannot see the destination PLC on the network for some reason. Status code errors in the high nibble of the status code indicate errors found by the PLC. These errors are generated when the data location is not available in the PLC or not writeable.

**See Also:**

Allen-Bradley documentation for error code definitions

---

**Unable to write to address. | Address = '<address>', DF1 status = <code>, Extended status = <code>.**

---

**Error Type:**

Warning

**Possible Cause:**

The address does not exist in the PLC.

**Possible Solution:**

Check the status and extended status codes returned by the PLC. Extended status codes may not always be returned and the error information is contained within the status code. The codes are displayed in hexadecimal.

**Note:**

Status code errors in the low nibble of the status code indicate errors found by the local node. Errors found by the local node occur when the KF module cannot see the destination PLC on the network for some reason. Status code errors in the high nibble of the status code indicate errors found by the PLC. These errors are generated when the data location is not available in the PLC or not writeable.

**See Also:**

Allen-Bradley documentation for error code definitions

---

**Unable to write to function file. | Function file = '<name>', DF1 status = <code>, Extended status = <code>.**

---

**Error Type:**

Warning

**Possible Cause:**

The address does not exist in the PLC.

**Possible Solution:**

Check the status and extended status codes returned by the PLC. Extended status codes may not always be returned and the error information is contained within the status code. The codes are displayed in hexadecimal.

**Note:**

Status code errors in the low nibble of the status code indicate errors found by the local node. Errors found by the local node occur when the KF module cannot see the destination PLC on the network for some reason. Status code errors in the high nibble of the status code indicate errors found by the PLC. These errors are generated when the data location is not available in the PLC or not writeable.

**See Also:**

Allen-Bradley documentation for error code definitions

---

**Unable to read block. | Block size = <number> (elements), Starting address = '<address>', DF1 status = <code>.**

---

**Error Type:**

Warning

**Possible Cause:**

The address does not exist in the PLC.

**Possible Solution:**

Check the status and extended status codes returned by the PLC. Extended status codes may not always be returned and the error information is contained within the status code. The codes are displayed in hexadecimal.

**Note:**

Status code errors in the low nibble of the status code indicate errors found by the local node. Errors found by the local node occur when the KF module cannot see the destination PLC on the network for some reason. Status code errors in the high nibble of the status code indicate errors found by the PLC. These errors are generated when the data location is not available in the PLC or not writeable.

**See Also:**

Allen-Bradley documentation for error code definitions

---

**Unable to read function file. | Function file = '<name>', DF1 status = <code>.**

---

**Error Type:**

Warning

**Possible Cause:**

The address does not exist in the PLC.

**Possible Solution:**

Check the status and extended status codes returned by the PLC. Extended status codes may not always be returned and the error information is contained within the status code. The codes are displayed in hexadecimal.

**Note:**

Status code errors in the low nibble of the status code indicate errors found by the local node. Errors found by the local node occur when the KF module cannot see the destination PLC on the network for some reason. Status code errors in the high nibble of the status code indicate errors found by the PLC. These errors are generated when the data location is not available in the PLC or not writeable.

**See Also:**

Allen-Bradley documentation for error code definitions

---

**Unable to write to address. | Address = '<address>', DF1 status = <code>.**

---

**Error Type:**

Warning

**Possible Cause:**

The address does not exist in the PLC.

**Possible Solution:**

Check the status and extended status codes returned by the PLC. Extended status codes may not always be returned and the error information is contained within the status code. The codes are displayed in hexadecimal.

**Note:**

Status code errors in the low nibble of the status code indicate errors found by the local node. Errors found by the local node occur when the KF module cannot see the destination PLC on the network for some reason. Status code errors in the high nibble of the status code indicate errors found by the PLC. These errors are generated when the data location is not available in the PLC or not writeable.

**See Also:**

Allen-Bradley documentation for error code definitions

---

**Unable to write to function file. | Function file = '<name>', DF1 status = <code>.**

---

**Error Type:**

Warning

**Possible Cause:**

The address does not exist in the PLC.

**Possible Solution:**

Check the status and extended status codes returned by the PLC. Extended status codes may not always be returned and the error information is contained within the status code. The codes are displayed in hexadecimal.

**Note:**

Status code errors in the low nibble of the status code indicate errors found by the local node. Errors found by the local node occur when the KF module cannot see the destination PLC on the network for some reason. Status code

errors in the high nibble of the status code indicate errors found by the PLC. These errors are generated when the data location is not available in the PLC or not writeable.

**See Also:**

Allen-Bradley documentation for error code definitions

---

**Unable to read tag. Internal memory is invalid. | Tag address = '<address>'.**

**Error Type:**

Warning

---

**Unable to read tag. Data type is illegal for this tag. | Tag address = '<address>', Data type = '<type>'.**

**Error Type:**

Warning

**Possible Cause:**

A read request for the specified tag failed because the client tag data type is illegal for the given controller tag.

**Possible Solution:**

Change the tag data type to one that is supported. For example, data type Short is illegal for a BOOL array Controller tag. Changing the data type to Boolean can remedy the problem.

**See Also:**

Addressing Atomic Data Types

---

**Unable to read block. Internal memory is invalid. Tag deactivated. | Tag address = '<address>'.**

**Error Type:**

Warning

---

**Unable to read block. Internal memory is invalid. Block deactivated. | Block size = <number> (elements), Block start address = '<address>'.**

**Error Type:**

Warning

---

**Unable to write to address. Internal memory is invalid. | Tag address = '<address>'.**

**Error Type:**

Warning

---

**Unable to read block. Block deactivated. | Block size = <number> (elements), Block start address = '<address>', CIP error = <code>, Extended error = <code>.**

**Error Type:**

Warning

**Possible Cause:**

The device returned an error within the CIP portion of the Ethernet/IP packet during a read request for the specified block.

**Possible Solution:**

The solution depends on the error codes returned.

**See Also:**

CIP Error Codes

---

**Device not responding. Local node responded with error. | DF1 status = <code>.**

---

**Error Type:**

Warning

**Possible Cause:**

The PLC did not respond to the request from the local node. A local node could be an intermediate node like 1756-DHRIO, 1756-CNB, 1761-NET-ENI, and so forth.

**Possible Solution:**

Refer Allen-Bradley documentation for error code definitions. For example, if STS code '0x02'(hex) is returned, verify the cabling between the remote node (PLC) and the local node.

**See Also:**

Allen-Bradley documentation for error code definitions

---

**Unable to write to function file. Local node responded with error. | Function file = '<name>', DF1 status = <code>.**

---

**Error Type:**

Warning

**Possible Cause:**

This error means that the PLC did not respond to the write request from the local node. A local node could be an intermediate node like 1756-DHRIO, 1756-CNB, 1761-NET-ENI, and so forth.

**Possible Solution:**

Refer to Allen-Bradley documentation for STS error code definitions. For example, if the STS code '0x02'(hex) is returned, verify the cabling between the remote node (PLC) and the local node.

**See Also:**

Allen-Bradley documentation for error code definitions

---

**Unable to write to address. Local node responded with error. | Function file = '<name>', DF1 status = <code>.**

---

**Error Type:**

Warning

**Possible Cause:**

This error means that the PLC did not respond to the write request from the local node. A local node could be an intermediate node like 1756-DHRIO, 1756-CNB, 1761-NET-ENI, and so forth.

**Possible Solution:**

Refer to Allen-Bradley documentation for STS error code definitions. For example, if the STS code '0x02'(hex) is returned, verify the cabling between the remote node (PLC) and the local node.

**See Also:**

Allen-Bradley documentation for error code definitions

---

**Unexpected offset encountered for tag. Tag will use Symbolic protocol. | Tag address = '<address>'.**

---

**Error Type:**

Warning

---

**Unexpected offset encountered for tag. | Tag address = '<address>'.**

**Error Type:**

Warning

---

**Unexpected offset/span encountered for tag. | Tag address = '<address>'.**

**Error Type:**

Warning

---

**Project download in progress or no project exists.**

**Error Type:**

Warning

---

**Project download complete.**

**Error Type:**

Warning

---

**Project online edit detected. Currently using Symbolic addressing.**

**Error Type:**

Warning

---

**Project offline edit detected. Currently using Symbolic addressing.**

**Error Type:**

Warning

---

**The following errors occurred uploading controller project from device. Resorting to symbolic protocol.**

**Error Type:**

Warning

---

**Unable to retrieve the identity for device. All tags will use Symbolic Protocol. | Encapsulation error = <code>.**

**Error Type:**

Warning

**Possible Cause:**

The device returned an error within the encapsulation portion of the Ethernet/IP packet during a request. Devices set to a Logical Mode revert to Symbolic Mode until the issue is resolved.

**Possible Solution:**

The driver attempts to recover from such an error. If the problem persists, contact Technical Support. This excludes error 0x02, which is device-related, not driver-related.

**See Also:**

Encapsulation Error Codes

---

**Unable to retrieve the identity for device. All tags will use Symbolic Protocol. | CIP error = <code>, Extended error = <code>.**

**Error Type:**

Warning

**Possible Cause:**

The device returned an error within the CIP portion of the Ethernet/IP packet during a request. Devices set to a Logical Mode revert to Symbolic Mode until the issue is resolved.

**Possible Solution:**

The solution depends on the error code that is returned. If the problem persists, contact Technical Support.

**See Also:**

CIP Error Codes

---

**Unable to retrieve the identity for device. Frame received contains errors. All tags will use Symbolic Protocol.**

---

**Error Type:**

Warning

**Possible Cause:**

1. The packets are misaligned due to connection and/or disconnection between the PC and device.
2. There is bad cabling connecting the devices that is causing noise.
3. The wrong frame size was received.
4. There is a TNS mismatch.
5. An invalid response command was returned from the device.
6. The device is not Ethernet/IP enabled.

**Possible Solution:**

1. The driver recovers from this error without intervention. If this error occurs frequently; there may be an issue with the cabling, the network, or the device itself.
2. Verify that the device being communicated with is an Ethernet-enabled device.

---

**Requested CIP connection size is not supported by this device. Automatically fall back to max. size. | Requested size = <number> (bytes), Max. size = <number> (bytes).**

---

**Error Type:**

Warning

**Possible Cause:**

The requested CIP connection size is not supported by the device.

**Possible Solution:**

Change the CIP connection size to one that is supported by the device.

**See Also:**

Logix Communications Parameters

---

**The tag import filename is invalid, file paths are not allowed.**

---

**Error Type:**

Warning

**Possible Cause:**

The tag import filename includes a path.

**Possible Solution:**

Remove the path from the filename.

---

**Read/Write requests to device stopped. Updating Logical Addresses from device project.**

---

**Error Type:**

Warning

---

**Read/Write requests to device resumed. Updating Logical Addresses from device complete. Currently using Logical addressing.**

---

**Error Type:**

Warning

---

**Unable to write to tag. Value written contains a syntax error. | Tag address = '<address>', Expected format = '<format>'.**

---

**Error Type:**

Warning

**Possible Cause:**

The string value written does not conform to the expected '<format>'.

**Possible Solution:**

1. Write a string value that conforms to the expected format without extra characters or embedded whitespace.
2. For time types, the driver supports the same literal strings supported by Studio 5000 so it can be used as a reference. For example, not all time parts are required but at least one part is required: T32#0us is allowed but T32# is not.

---

**Unable to write to tag. Value written is out of range. | Tag address = '<address>'.**

---

**Error Type:**

Warning

**Possible Cause:**

1. The string value written would exceed the minimum or maximum value allowed for the controller tag's data type.
2. The integer value written exceeds the minimum or maximum value allowed for the controller tag's data type.

**Possible Solution:**

Write a string or integer value that does not exceed the range of the controller tag's data type. For example, the maximum TIME integer value is 2725199999999 which correlates to the string literal 'T#31d\_12h\_59m\_59s\_999ms\_999us'; 'T#31d\_13h' would be out of range.

---

**Invalid attributes encountered while uploading program information. All tags for this program will use Symbolic Protocol. | Program name = '<name>'.**

---

**Error Type:**

Warning

**Possible Cause:**

Controller firmware does not support Logical Protocol Mode access to program tags.

**Possible Solution:**

Add controller logic to move program tag data to controller-level tags for Logical Protocol Mode access.

---

**Database error. Maximum number of supported programs reached. No tags will be created for this program. | Program name = '<name>', Max. programs = <count>.**

**Error Type:**

Warning

**Possible Cause:**

The maximum number of supported programs has been reached while automatically generating tags using Database Import Method: Create From Device.

**Possible Solution:**

1. Contact Technical Support to report the issue.
2. Use Database Import Method: Create From Import File from L5K or L5X. Note that if the server device is configured for Logical Protocol Mode, tags belonging to programs exceeding the maximum will use Symbolic Protocol Mode.

---

**Maximum number of supported programs reached. All tags for this program will use Symbolic Protocol. | Program name = '<name>', Max. programs = <count>.**

**Error Type:**

Warning

**Possible Cause:**

The maximum number of supported programs has been reached while the device is configured in a Logical Protocol Mode.

**Possible Solution:**

Contact Technical Support to report the issue.

---

**Database status. Importing non-alias tags.**

**Error Type:**

Informational

---

**Database status. Importing alias tags.**

**Error Type:**

Informational

---

**Database status. Building tag projects, please wait. | Tag project count = <number>.**

**Error Type:**

Informational

---

**Database error. Tag renamed because it exceeds max. character length. | Tag name = '<tag>', Max. length = <number>, New tag name = '<tag>'.**

**Error Type:**

Informational

---

**Database error. Array tags renamed because they exceed max. character length. | Array tags = '<tags>', Max. length = <number>, New array tags = '<tags>'.**

**Error Type:**

Informational

**Database error. Program group name exceeds max. character length. Program group renamed. | Group name = '<name>', Max. length = <number>, New group name = '<name>'.**

---

**Error Type:**

Informational

**Database status. Retrieving controller project.**

---

**Error Type:**

Informational

**Database status. | Program count = <number>, Data type count = <number>, Imported tag count = <number>.**

---

**Error Type:**

Informational

**Database status. Generating OPC tags.**

---

**Error Type:**

Informational

**Low memory resources.**

---

**Error Type:**

Informational

**Unknown error occurred.**

---

**Error Type:**

Informational

**Database status. Importing tags from .L5X file. | Schema revision = '<value>', Software revision = '<value>'.**

---

**Error Type:**

Informational

**Details. | IP = '<address>', Vendor ID = <vendor>, Product type = <type>, Product code = <code>, Revision= <value>, Product name = '<name>', Product S/N = <number>.**

---

**Error Type:**

Informational

**Elapsed time = <number> (seconds).**

---

**Error Type:**

Informational

**Symbolic device reads = <number>.**

---

**Error Type:**

Informational

**Symbolic, array block device reads = <number>.**

---

**Error Type:**

Informational

---

**Symbolic, array block cache reads = <number>.**

**Error Type:**

Informational

---

**Symbol instance non-block device reads = <number>.**

**Error Type:**

Informational

---

**Symbol instance non-block, array block device reads = <number>.**

**Error Type:**

Informational

---

**Symbol instance non-block, array block cache reads = <number>.**

**Error Type:**

Informational

---

**Symbol instance block device reads = <number>.**

**Error Type:**

Informational

---

**Symbol instance block cache reads = <number>.**

**Error Type:**

Informational

---

**Physical non-block device reads = <number>.**

**Error Type:**

Informational

---

**Physical non-block, array block device reads = <number>.**

**Error Type:**

Informational

---

**Physical non-block, array block cache reads = <number>.**

**Error Type:**

Informational

---

**Physical block device reads = <number>.**

**Error Type:**

Informational

---

**Physical block cache reads = <number>.**

**Error Type:**

Informational

---

**Tags read = <number>.**

**Error Type:**

Informational

**Packets sent = <number>.**

---

**Error Type:**

Informational

**Packets received = <number>.**

---

**Error Type:**

Informational

**Initialization transactions = <number>.**

---

**Error Type:**

Informational

**Read/Write transactions = <number>.**

---

**Error Type:**

Informational

**Avg. packets sent/sec = <number>.**

---

**Error Type:**

Informational

**Avg. packets received/sec = <number>.**

---

**Error Type:**

Informational

**Avg. tag reads/sec = <number>.**

---

**Error Type:**

Informational

**Avg. tags/transaction = <number>.**

---

**Error Type:**

Informational

-----  
**Error Type:**

Informational

**%s | DEVICE STATISTICS**

---

**Error Type:**

Informational

**Avg. device turn-around time = <number> (milliseconds)**

---

**Error Type:**

Informational

**%s | CHANNEL STATISTICS**

---

**Error Type:**

Informational

---

**DRIVER STATISTICS**

---

**Error Type:**

Informational

**Device tag import aborted.**

---

**Error Type:**

Informational

**Import file '%s' not found at path '%s'.**

---

**Error Type:**

Informational

**Errors occurred retrieving controller project.**

---

**Error Type:**

Informational

**Internal driver error occurred.**

---

**Error Type:**

Informational

**Invalid or corrupt controller project detected while synchronizing. Try again later.**

---

**Error Type:**

Informational

**Project download detected while synchronizing. Try again later.**

---

**Error Type:**

Informational

**Low memory resources.**

---

**Error Type:**

Informational

**L5K file is invalid or corrupt.**

---

**Error Type:**

Informational

**Unknown error occurred.**

---

**Error Type:**

Informational

**Database error. PLC5/SLC/MicroLogix devices do not support this function.**

---

**Error Type:**

Informational

**L5X file is invalid or corrupt.**

---

**Error Type:**

Informational

---

**Import file '<empty>' not found at path '<empty>'.**

**Error Type:**

Informational

---

**Import file '%s' not found at path '<empty>'.**

**Error Type:**

Informational

---

**Import file '<empty>' not found at path '%s'.**

**Error Type:**

Informational

---

**XML element failed post-schema validation. Importing tags from device is not supported for model. Use alternative element. | XML element = '{<namespace><element>', Unsupported model = '<model>', Alternative XML element = '{<namespace><element>'.**

**Error Type:**

Security

---

**Value not supported for an XML element on this model. Automatically setting to new value. | Value = '<value>', XML element = '{<namespace><element>', Model = '<model>', New value = '<value>'.**

**Error Type:**

Security

# Appendices

Select a link from the list below for more information on a specific topic.

[Channel Properties](#)

[Device Properties](#)

[Tag Properties](#)

[Logix Setup](#)

[1761-NET-ENI Setup](#)

[Data Highway Plus Gateway Setup](#)

[Communications Routing](#)

[Serial Gateway Setup](#)

[Data Highway Plus Gateway](#)

[ControlNet Gateway](#)

[EtherNet/IP Gateway Setup](#)

[MicroLogix 1100 Setup](#)

[Choosing a Protocol Mode](#)

[Detecting a Change in the Controller Project](#)

[SoftLogix 5800 Connection Notes](#)

[Glossary](#)

## Allen-Bradley ControlLogix Ethernet Channel Properties

Below is a list of Allen-Bradley ControlLogix Ethernet channel-level properties.

```
{
  "common.ALLTYPES_NAME": "MyChannel",
  "common.ALLTYPES_DESCRIPTION": "",
  "servermain.MULTIPLE_TYPES_DEVICE_DRIVER": "Allen-Bradley ControlLogix Ethernet",
  "servermain.CHANNEL_DIAGNOSTICS_CAPTURE": false,
  "servermain.CHANNEL_UNIQUE_ID": 4126021724,
  "servermain.CHANNEL_ETHERNET_COMMUNICATIONS_NETWORK_ADAPTER_STRING": "",
  "servermain.CHANNEL_WRITE_OPTIMIZATIONS_METHOD": 2,
  "servermain.CHANNEL_WRITE_OPTIMIZATIONS_DUTY_CYCLE": 10,
  "servermain.CHANNEL_NON_NORMALIZED_FLOATING_POINT_HANDLING": 0,
}
```

## Allen-Bradley ControlLogix Ethernet Device Properties

Below is a list of Allen-Bradley ControlLogix Ethernet device-level properties.

```
{
  "common.ALLTYPES_NAME": "MyDevice",
  "common.ALLTYPES_DESCRIPTION": "",
  "servermain.MULTIPLE_TYPES_DEVICE_DRIVER": "Allen-Bradley ControlLogix Ethernet",
  "servermain.DEVICE_MODEL": 0,
  "servermain.DEVICE_UNIQUE_ID": 1286734974,
  "servermain.DEVICE_CHANNEL_ASSIGNMENT": "Channel1",
  "servermain.DEVICE_ID_FORMAT": 0,
  "servermain.DEVICE_ID_STRING": "<10.10.110.15>,1,0",
  "servermain.DEVICE_ID_HEXADECIMAL": 0,
  "servermain.DEVICE_ID_DECIMAL": 0,
  "servermain.DEVICE_ID_OCTAL": 0,
  "servermain.DEVICE_DATA_COLLECTION": true,
  "servermain.DEVICE_SIMULATED": false,
  "servermain.DEVICE_SCAN_MODE": 0,
  "servermain.DEVICE_SCAN_MODE_RATE_MS": 1000,
  "servermain.DEVICE_SCAN_MODE_PROVIDE_INITIAL_UPDATES_FROM_CACHE": false,
}
```







## Logix Device IDs

For information on ENI device ID setup, refer to [1761-NET-ENI Setup](#).

### ControlLogix 5500 Ethernet

The device ID specifies the device IP address, as well as the slot number in which the controller CPU resides. Device IDs are specified as the following:

*<IP or hostname>, 1, [<optional routing path>], <CPU Slot>*

Designator	Designator Type*	Description	Formats	Range
IP/Host Name	N/A	IP Address or host name.	Decimal	0-255
1	Port ID	Port to backplane.	Decimal	1
Optional Routing Path	Multiple Link, port pairs	Specifies a way out of the EtherNet/IP interface module and must equal 1 (port to the backplane).	Decimal	*
CPU Slot	Link Address	Slot number of the ControlLogix processor.	Decimal	0-255

\*For more information, refer to [Connection Path Specification](#).

#### Example

123.123.123.123,1,0

This equates to an Ethernet/IP of 123.123.123.123. The port ID is 1 and the CPU resides in slot 0.

### CompactLogix 5300 Ethernet Device ID

The device ID specifies the device IP address, as well as the slot number in which the controller CPU resides. Device IDs are specified as the following:

*<IP or hostname>, 1, [<optional routing path>], <CPU Slot>*

Designator	Designator Type*	Description	Formats	Range
IP/Host Name	N/A	CompactLogix Ethernet IP Address or host name.	Decimal	0-255
1	Port ID	Port to backplane.	Decimal	1
Optional Routing Path	Multiple Link, port pairs	Specifies a way out of the Ethernet port and must equal 1 (port to the backplane).	Decimal	*
CPU Slot	Link Address	Slot number of the CompactLogix processor.	Decimal	0-255

\*For more information, refer to [Connection Path Specification](#).

#### Example

123.123.123.123,1,0

This equates to CompactLogix IP of 123.123.123.123. The port ID is 1 and the CPU resides in slot 0.

### FlexLogix 5400 Ethernet Device ID

The device ID specifies the device IP address, as well as the slot number in which the controller CPU resides. Device IDs are specified as the following:

*<IP or hostname>, 1, [<optional routing path>], <CPU Slot>*

Designator	Designator Type*	Description	Formats	Range
IP/Host Name	N/A	1788-ENBT IP Address or host name.	Decimal	0-255

Designator	Designator Type*	Description	Formats	Range
1	Port ID	Port to backplane.	Decimal	1
Optional Routing Path	Multiple Link, port pairs	Specifies a way out of the 1788-ENBT interface module and must equal 1 (port to the backplane).	Decimal	*
CPU Slot	Link Address	Slot number of the FlexLogix processor.	Decimal	0-255

\*For more information, refer to [Connection Path Specification](#).

#### Example

123.123.123.123,1,0

This equates to 1788-ENBT IP of 123.123.123.123. The port ID is 1 and the CPU resides in slot 0.

### SoftLogix 5800 Device ID

The device ID specifies the SoftLogix PC IP address, as well as the virtual slot number in which the controller CPU resides. Device IDs are specified as the following:

<IP or hostname>,1,[<optional routing path>],<CPU Slot>

Designator	Designator Type*	Description	Formats	Range
IP/Host Name	N/A	SoftLogix PC NIC IP Address or host name.	Decimal	0-255
1	Port ID	Port to backplane.	Decimal	1
Optional Routing Path	Multiple Link, port pairs	Specifies a way out of the EtherNet/IP Messaging module and must equal 1 (port to the virtual backplane).	Decimal	*
CPU Slot	Link Address	Slot number of the SoftLogix processor in the virtual backplane.	Decimal	0-255

\*For more information, refer to [Connection Path Specification](#).

#### Example

123.123.123.123,1,1

This equates to SoftLogix PC IP Address of 123.123.123.123. The port ID is 1 and the CPU resides in slot 1.

For information on supplementing a device ID with a routing path to a remote backplane, refer to [Communications Routing](#).

See Also: [SoftLogix 5800 Connection Notes](#)

### 1761-NET-ENI Setup

1761-NET-ENI provides a means of communicating with ControlLogix, CompactLogix, FlexLogix, MicroLogix, SLC 500, and PLC-5 Series PLCs on Ethernet with the Allen-Bradley ControlLogix Ethernet Driver.

#### Requirements

MicroLogix, SLC 500, or PLC-5 series PLC supporting Full Duplex DF1 utilizing the CH0 RS232 channel.  
1761-NET-ENI Device Series A, B, C, or D.

ControlLogix, CompactLogix or FlexLogix PLC utilizing the CH0 RS232 channel.  
1761-NET-ENI Device Series B and newer.

Notes:

1. For communications parameters, database settings, and project/protocol options, ENI ControlLogix, CompactLogix, and FlexLogix users should refer to the "Logix Setup" book in the Table of Contents.
2. To turn on the **CompactLogix Routing** option (located in the utility's **ENI IP Addr** tab), use the ENI / ENIW utility supplied by Allen-Bradley. This was tested on an ENI module with Firmware revision 2.31.

● The ENI module has a limited number of TCP connections. As such, users should avoid applications that communicate with the module (such as RSLinx/RWho) so that connections are available for the driver.

### ENI Device ID

The device ID specifies the IP address of the 1761-NET-ENI. Device IDs are specified as the following:

<IP Address>

Designator	Designator Type	Description	Formats	Range
IP Address	N/A	1761-NET-ENI IP address	Decimal	0-255

#### Example

123.123.123.123

This equates to an ENI IP of 123.123.123.123. Since the device only supports Full Duplex DF1, a node ID is not required.

● For more information on communications parameters, refer to [Logix Communications Parameters](#).

### Data Highway™ Plus Gateway Setup

DH+ Gateway provides a means of communicating with SLC 500 and PLC-5 series PLC on DH+ with the Allen-Bradley ControlLogix Ethernet Driver.

#### Requirements

EtherNet/IP Interface module.  
 1756-DHRIO Interface Module with appropriate channel configured for DH+.  
 SLC500 or PLC-5 series PLC on DH+ network.

● **Note:** DH+ Gateway models do not support automatic tag database generation.

#### DH+ Gateway Device ID

The device ID specifies the device IP address as well as the DH+ parameters necessary for making a connection. Device IDs are specified as the following:

<IP or hostname>, 1,[<optional routing path>],<DHRIO Slot>.<DHRIO Channel>.<DH+ Node ID (dec)>

Designator	Designator Type*	Description	Formats	Range
IP/Host Name	N/A	IP Address or host name	Decimal	0-255
1	Port ID	Port to backplane	Decimal	1
Optional Routing Path	Multiple Link, port pairs	Specifies a way out of the EtherNet/IP interface module and must equal 1 (port to the backplane)	Decimal	*
DHRIO Slot	Link Address	Slot number of the 1756-DHRIO interface module	Decimal	0-255
DHRIO Channel		DH+ channel to use	Alpha	A and B
DH+ Node ID		DH+ node ID of target PLC in Decimal Format**	Decimal	0-99

- \*For more information, refer to [Connection Path Specification](#).
- \*\*For more information, refer to "Node ID Octal Addressing" below.

**Example**

123.123.123.123,1,2.A.3

This equates to an Ethernet/IP of 123.123.123.123. The DH+ card resides in slot 2: use DH+ channel A and addressing target DH+ Node ID 3 (dec).

**Node ID Octal Addressing**

The DH+ node ID is specified in Octal format in the PLC and requires a conversion to Decimal format for use in the DH+ Gateway device ID. The node ID can be located in RSWho within RSLinx. It is displayed in Octal format.

**Example**

DH+ Node 10 (octal) in RSWho = DH+ Node 8 (decimal) in DH+ Gateway device ID.

It is important to verify communications with the proper controller. In the example above, if 10 was entered as the DH+ node ID in the DH+ Gateway device ID, then communications would take place with Node 12 (octal equivalent of 10 decimal) and not Node 10 (octal). If Node 12 (octal) does not exist, then the DHRIO module would return DF1 STS 0x02. This means that the link layer cannot guarantee delivery of the packet. In short, the DH+ node cannot be located on the DH+ network.

- For information on supplementing a device ID with a routing path to a remote DH+ node, refer to [Communications Routing](#).
- For more information on communications parameters, refer to [ENI DF1/DH+/ControlNet Gateway Communications Parameters](#).

**ControlNet™ Gateway Setup**

ControlNet Gateway provides a means of communicating with PLC-5C series PLCs on ControlNet with the Allen-Bradley ControlLogix Ethernet Driver.

**Requirements**

EtherNet/IP Interface Module.  
1756-CNB or 1756-CNBR Interface Module.  
PLC-5C series PLC on ControlNet network.

- **Note:** ControlNet Gateway models do not support automatic tag database generation.

**ControlNet Gateway Device ID**

The device ID specifies the device IP address in addition to the ControlNet parameters necessary for making a connection. Device IDs are specified as the following:

<IP or hostname>,1,[<optional routing path>],<CNB Slot>.<CNB Channel>.<ControlNet Node ID (dec)>

Designator	Designator Type*	Description	Formats	Range
IP/Host Name	N/A	IP Address or host name	Decimal	0-255
1	Port ID	Port to backplane	Decimal	1
Optional Routing Path	Multiple Link, port pairs	Specifies a way out of the EtherNet/IP communication module and must equal 1 (port to the backplane)	Decimal	*
CNB Slot	Link Address	Slot Number of the 1756-CNB/CNBR interface module	Decimal	0-255
CNB Channel	Port ID	The ControlNet channel to use	Alpha	A and B
ControlNet Node ID	Link Address	ControlNet node ID of target PLC in decimal format**	Decimal	0-99

- \*For more information, refer to [Connection Path Specification](#).
- \*\*For more information, refer to "Node ID Octal Addressing" below.

**Example**

123.123.123.123,1,2.A.3

This equates to an Ethernet/IP of 123.123.123.123. The ControlNet card resides in slot 2: use ControlNet channel A and addressing target ControlNet Node ID 3.

**Node ID Octal Addressing**

The ControlNet node ID is specified in Octal format in the PLC and requires a conversion to Decimal format for use in the ControlNet Gateway device ID. The node ID can be located in RSWho within RSLinx. It is displayed in Octal format.

**Example**

CN node 10 (octal) in RSWho = CN node 8 (decimal) in ControlNet Gateway device ID.

It is important to verify communications with the proper controller. In the example above, if 10 was entered as the ControlNet node ID in the ControlNet Gateway device ID, communications take place with Node 12 (octal equivalent of 10 decimal), not Node 10 (octal). If Node 12 (octal) does not exist, the CNB module returns DF1 STS 0x02. This means that the link layer could not guarantee delivery of the packet. In short, the ControlNet node could not be located on the ControlNet network.

- For more information on supplementing a device ID with a routing path to remote ControlNet node, refer to [Communications Routing](#).
- For more information on communications parameters, refer to [ENI DF1/DH+/ControlNet Gateway Communications Parameters](#).

**EtherNet/IP Gateway Setup**

EtherNet/IP Gateway provides a means of communicating with MicroLogix, SLC 500, and PLC-5 series PLC on EtherNet/IP with the Allen-Bradley ControlLogix Ethernet Driver.

**Requirements**

2 or more EtherNet/IP Interface modules (such as 1756-ENBT).  
MicroLogix, SLC500, or PLC-5 series PLC with EtherNet/IP connectivity.

- **Note** : EthernetIP Gateway models do not support automatic tag database generation.

**EtherNet/IP Gateway Device ID**

The device ID specifies the local device IP address as well as the remote EtherNet/IP address necessary for making a connection. Device IDs are specified as the following:

<IP or hostname>, 1, [<optional routing path>], <ENBT Slot>. <ENBT Channel>. <Remote IP>

Designator	Designator Type*	Description	Formats	Range
IP/Host Name	N/A	IP Address or host name of the local EtherNet/IP interface module	Decimal	0-255
1	Port ID	Port to backplane	Decimal	1
Optional Routing Path	Multiple Link, port pairs	Specifies a way out of the EtherNet/IP interface module and must equal 1 (port to the backplane)	Decimal	*
ENBT Slot	Link Address	The slot number of the second EtherNet/IP interface module	Decimal	0-255
ENBT Channel	Port ID	The Ethernet/IP port to use	Alpha	A and B
Remote IP Address	Link Address	The remote IP address of the target PLC	Decimal	0-255

• *For more information, refer to [Connection Path Specification](#).*

#### Example

123.123.123.123,1,2.A.192.168.1.10

This equates to a local IP of 123.123.123.123. The second Ethernet/IP card resides in slot 2: use port A and addressing target device with IP 192.168.1.10.

• **Note:** When configuring the device ID, verify that the device can be detected using the same route through RSLinx.

• *For information on supplementing a device ID with a routing path to a remote Ethernet/IP device, refer to [Communications Routing](#).*

• *For more information on communications parameters, refer to [ENI DF1/DH+/ControlNet Gateway Communications Parameters](#).*

## Serial Gateway Setup

Serial Gateway provides a means of communicating with ControlLogix, CompactLogix, FlexLogix, and SoftLogix PLCs on a serial network with the Allen-Bradley ControlLogix Ethernet Driver.

### Requirements

EtherNet/IP Interface module

Local CPU with a serial port

Remote ControlLogix, CompactLogix, FlexLogix, or SoftLogix CPU with a serial port

#### Notes:

1. Local and Remote CPUs must be on the same serial network.
2. Serial Gateway models do not support automatic tag database generation.

### Serial Gateway Device ID

The device ID specifies the local device IP address as well as the remote device station ID necessary for making a connection. Device IDs are specified as the following:

<IP or hostname>,1,<Optional Routing Path>,<CPU Slot>.<Serial Port Channel>.<Station ID (dec)>

Designator	Designator Type*	Description	Formats	Range
IP/Host Name	N/A	IP address or host name	Decimal	0-255
1	Port ID	Port to backplane	Decimal	1
Optional Routing Path	Multiple Link, port pairs	Specifies a way out of the EtherNet/IP interface module and must equal 1 (port to the backplane)	Decimal	*
CPU Slot	Link Address	Slot number of the CPU module that contains the serial port used for communications	Decimal	0-255
Serial Port Channel		Serial port channel to use	Alpha	A and B
Station ID		DF1 station ID of target PLC in Decimal Format**	Decimal	0-255

• *For more information, refer to [Connection Path Specification](#).*

#### Example

123.123.123.123,1,0.A.3

This equates to an Ethernet/IP of 123.123.123.123. The CPU card resides in slot 0: use Channel A (serial port) and addressing target station ID 3 (dec).

**Notes:**

1. For information on supplementing a Device ID with a routing path to a remote serial node, refer to [Communications Routing](#).
2. For more information on communications parameters, refer to [Logix Communications Parameters](#).
3. When configuring the Device ID, users should verify that the device can be detected using the same route through RSLinx.

## MicroLogix 1100 Setup

### MicroLogix 1100 Device ID

The Device ID specifies the IP address of the MicroLogix 1100. Device IDs are specified as the following:

<IP or hostname>

Designator	Designator Type	Description	Formats	Range
IP/Host Name	N/A	IP Address or host name	Decimal	0-255

**Example**

123.123.123.123

This equates to an IP of 123.123.123.123.

For more information on communications parameters, refer to [ENI DF1/DH+/ControlNet Gateway Communications Parameters](#).

## Communications Routing

Routing provides a way to communicate with a remote device over various networks. It can be thought of as a bridge between the local device and a remote device even if they are on two different field bus networks. Access to a remote (destination) backplane allows for direct communication with the supported modules located on this backplane. Supported modules include the following:

- ControlLogix 5500 processor for ControlLogix applications.
- SoftLogix 5800 processor for SoftLogix applications.
- 1756-DHRIO interface module for DH+ Gateway applications.
- 1756-CNB or 1756-CNBR interface module for ControlNet Gateway applications.

A routing path is a series of backplane hops, whose last hop points to the destination backplane. Each hop requires a Logix backplane (not a Logix processor). An individual hop can utilize one of the following networks as its medium:

- ControlNet
- DH+
- TCP/IP (Ethernet/IP)

**Important:** Routing is not supported for ENI and MicroLogix 1100 models.

## Connection Path Specification

The routing path is specified in the device ID. As with non-routing applications, communication originates from the Allen-Bradley ControlLogix Ethernet Driver on the PC and is directed at the local Ethernet module. Once at this local Ethernet module, the device ID specifies a way out of the module and onto the backplane, just like with non-routing applications. The routing path directs the message to the desired Logix backplane. The device ID also determines what device is communicated with (such as the ControlLogix processor, SoftLogix processor, DH+ node, or ControlNet node).

The routing path specification begins and ends with the left and right bracket respectively ([ ]). The path itself is a series of port/link address pairs, identical to the communication path syntax in RSLogix 5000 Message Configuration dialog.

Designator Type	Description	Formats	Range
Port ID	Specifies a way out of the interface module in question.*	Decimal	0-65535
Link Address	If the corresponding port is the backplane, the link address is the slot number of the interface module that goes out. If the corresponding port is an interface module port, the link address specifies a destination node as follows. - DH+/ControlNet: node ID - EtherNet/IP communication module: IP address - SoftLogix EtherNet/IP module: IP address	Decimal	0-255

\*For more information, refer to "Port Reference" below.

**Single Hop**

IP Address, Port ID0, [Link Address0, Port ID1, Link Address1, Port ID2], Link Address2.

**Multi-Hop (N Hops)**

IP Address, Port ID0, [Link Address0, Port ID1, Link Address1, Port ID2, Link Address2, ... Port ID(N+1), Link Address(N+1), Port ID(N+2)], Link Address(N+2).

**Notes:**

1. The last port ID in the path (Port ID2 and Port ID(N+2) for single-hop and multi-hop respectively) must be 1 (port for backplane).
2. Port ID0 must be 1 (port for backplane). Link Address2 and Link Address (N+2) are the slot numbers of the remote Logix processor/1756-DHRIO module/1756-CNB module.

**Port Reference**

Interface Module	Port 1	Port 2	Port 3
EtherNet/IP Communication Module	Backplane	Ethernet Network	N/A
SoftLogix EtherNet/IP Messaging Module	Virtual Backplane	Ethernet Network	N/A
1756-DHRIO	Backplane	DH+ Network on Ch. A	DH+ Network on Ch. B
1756-CNB	Backplane	ControlNet Network	N/A

**Application Notes**

1. Messages cannot be routed in or out of the same interface module channel more than once within the path. Doing so results in CIP error 0x01 Ext. error 0x100B.
2. For multiple channel interface modules, messages cannot be routed into and then immediately out of that same module (using different channels), regardless of whether the message is directed to the backplane first or avoids the backplane all together. As previously mentioned, the latter is not supported since each hop requires a ControlLogix backplane. An example would be to route a DH+ message from one DH+ link (such as Channel A of 1756-DHRIO) to another DH+ link (such as Channel B of same 1756-DHRIO) through one 1756-DHRIO-interface module. This is commonly referred to as Remote DH+ messaging and is not supported.

## Routing Examples

The routing examples below include the entire device ID minus the IP of the local 1756-ENBT. The perspective of the device ID/routing path is from the local 1756-ENBT Module. Hop descriptions are in the following form:

*Link Address (N), Port ID(N+1), Link Address(N+1), Port ID(N+2)*

For more information, refer to [Connection Path Specification](#). For further details on building a connection/routing path, refer to Allen-Bradley Publication 1756-6.5.14, pp. 4-5 through 4-8.

In the illustration below, all DH+/ControlNet node IDs are specified in decimal format. The node ID specified in the PLC and displayed in RSWho is in Octal format. Descriptions of the colors are as follows:

- Green = Ethernet
- Blue = DH+
- Orange = ControlNet

For more information, refer to [Data Highway Plus Gateway Setup](#) and [ControlNet Gateway Setup](#).

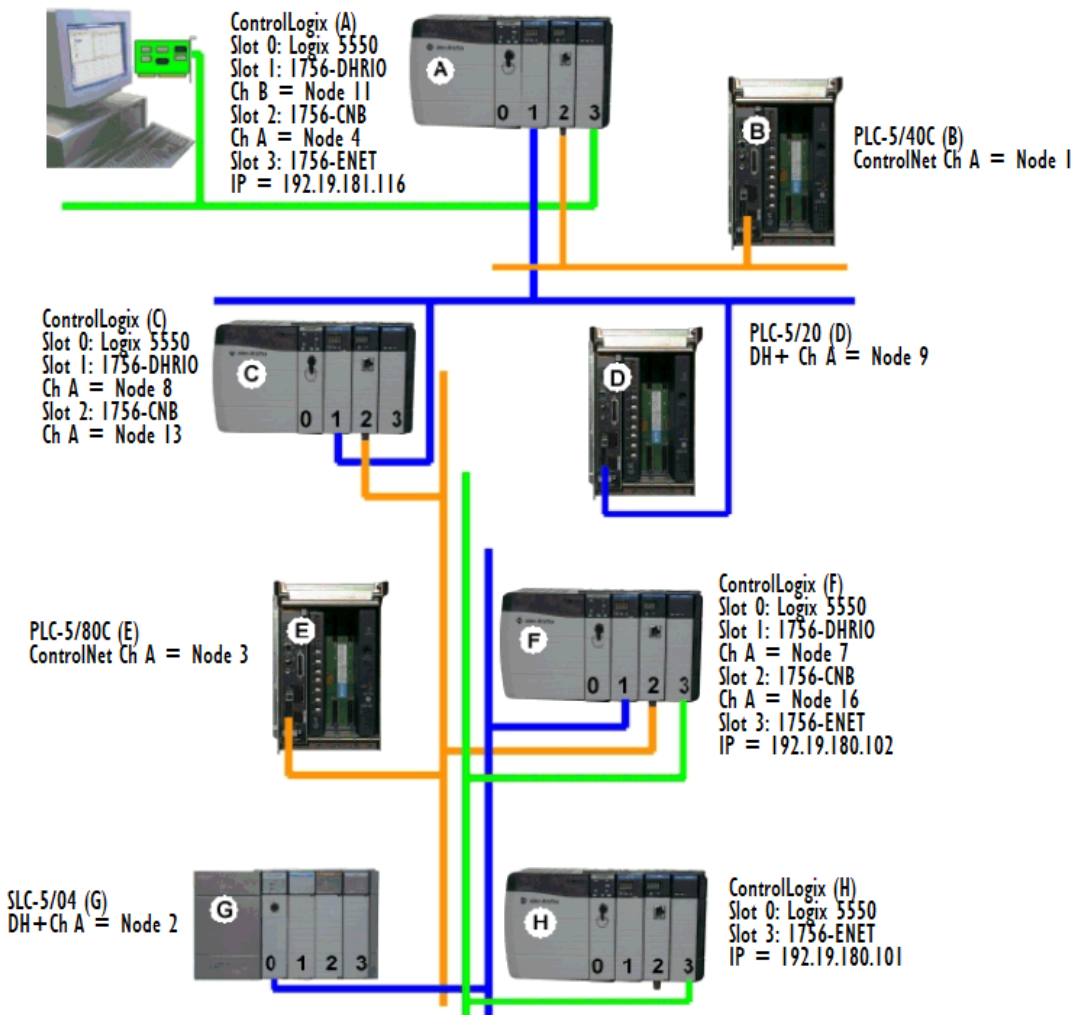

### Example 1

Logix5550 to PLC-5 via DH+ Gateway.

Destination Node	Model	Routing	Device ID less IP
PLC-5/20 (D)	DH+ Gateway	No	1,1.B.9

### Example 2

Logix5550 to PLC-5C via CN Gateway.

Destination Node	Model	Routing	Device ID less IP
PLC-5/40C (B)	CN Gateway	No	1,2.A.1

### Example 3

Logix5550 to Logix5550 via routing over DH+.

Destination Node	Model	Routing	Device ID less IP
Logix5550 (C)	ControlLogix 5550	Yes	1,[1,2,8,1],0

Routing Path Breakdown for Example 3.

Hop	Segment	Description
1	1,2,8,1	Slot 1 (DHRIO) -> Port 2 (DH+ Ch A) -> DH+ Node 8 -> Logix C backplane

### Example 4

Logix5550 to PLC-5C via CN Gateway, routing over DH+.

Destination Node	Model	Routing	Device ID less IP
PLC-5/80C (E)	CN Gateway	Yes	1,[1,2,8,1],2.A.3

Routing Path Breakdown for Example 4.

Hop	Segment	Description
1	1,2,8,1	Slot 1 (DHRIO) -> Port 2 (DH+ Ch A) -> DH+ Node 8 -> Logix C backplane

### Example 5

Logix5550 to Logix5550 via routing over DH+, ControlNet

Destination Node	Model	Routing	Device ID less IP
Logix5550 (F)	ControlLogix 5550	Yes	1,[1,2,8,1,2,2,15,1],0

Routing Path Breakdown for Example 5.

Hop	Segment	Description
1	1,2,8,1	Slot 1 (DHRIO) -> Port 2 (DH+ Ch A) -> DH+ Node 8 -> Logix C backplane
2	2,2,15,1	Slot 2 (CNB) -> Port 2 (CN Ch A) -> CN Node 15 -> Logix F backplane

### Example 6

Logix5550 to SLC 5/04 via routing over DH+, ControlNet.

Destination Node	Model	Routing	Device ID less IP
SLC 5/04 (G)	DH+ Gateway	Yes	1,[1,2,8,1,2,2,15,1],1.A.2

Routing Path Breakdown for Example 6.

Hop	Segment	Description
1	1,2,8,1	Slot 1 (DHRIO) -> Port 2 (DH+ Ch A) -> DH+ Node 8 -> Logix C backplane
2	2,2,15,1	Slot 2 (CNB) -> Port 2 (CN Ch A) -> CN Node 15 -> Logix F backplane

### Example 7

Logix5550 to Logix5550 via routing over DH+, ControlNet, Ethernet.

Destination Node	Model	Routing	Device ID less IP
Logix5550 (H)	ControlLogix 5550	Yes	1, [1,2,8,1,2,2,15,1,3,2,192.192.180.101,1],0

Routing Path Breakdown for Example 7.

Hop	Segment	Description
1	1,2,8,1	Slot 1 (DHRIO) -> Port 2 (DH+ Ch A) -> DH+ Node 8 -> Logix C backplane
2	2,2,15,1	Slot 2 (CNB) -> Port 2 (CN Ch A) -> CN Node 15 -> Logix F backplane
3	3,2,192.192.180.101,1	Slot 3 (ENBT) -> Port 2 -> Remote1756-ENBT IP -> Logix H backplane

## Choosing a Protocol Mode

### Symbolic Mode

Symbolic Mode represents each client / server tag address in the packet by its ASCII character name.

Benefits	Detriments
<ol style="list-style-type: none"> <li>All the information needed to make a data request lies in the client / server tag's address.</li> <li>Only the data that is being accessed in the client / server tags are requested from the PLC.</li> <li>Backward compatible.</li> </ol>	<ol style="list-style-type: none"> <li>High device turnaround time when processing the symbolic addresses.</li> <li>Less requests per multi-request packet because the size of each request varies.</li> </ol>

#### Notes:

- To take advantage of the multi-request packet optimization, as many tags should be represented in a single packet as possible. Since tag addresses are represented by their ASCII character name in the packet, the tag addresses should be as short as possible. For example, "MyTag" is preferred over "MyVeryLongTagNameThatContains36Chars."
- When the default data type property is set to "Default," automatic tag generation creates tags with a data type that matches the type in the controller.

### Logical Modes

Logical Non-Blocking and Logical Blocking encapsulate two read protocols. The protocol used is automatically determined by the driver and is based on the controller revision. The table below summarizes the modes and the protocols to which they map.

Protocol Mode	Read Protocol Used		Write Protocol Used
	FRN V21 and Higher	FRN V20 and Lower	All FRN
Symbolic	Symbolic (Non-Blocking)	Symbolic (Non-Blocking)	Symbolic
Logical Non-Blocking	Symbol Instance Non-	Physical Non-Blocking*	Symbol Instance

Protocol Mode	Read Protocol Used		Write Protocol Used
	Blocking		
Logical Blocking	Symbol Instance Blocking	Physical Blocking*	Symbol Instance

\*Deprecated in V21.

The information necessary to perform Logical reads is retrieved in a controller project upload sequence performed automatically by the driver. For the sake of brevity, the term "Logical Address" represents the Symbol Instance ID or Physical Address, depending on the protocol used. The Logical Modes avoid the time-consuming address parsing and lookups that are required for every symbolic request.

**Note:** These Logical Modes are not available to Serial Gateway models.

**Logical Non-Blocking Mode**

Logical Non-Blocking Mode requests all client / server tags individually and at a fixed size.

Benefits	Detriments
<ol style="list-style-type: none"> <li>1. Contains the maximum request per multi-request packet because each request is a fixed size.</li> <li>2. Low device turnaround time because the client / server tags are specified in the packet with the logical address.</li> <li>3. Only the data that is being accessed in the client / server tags are requested from the PLC.</li> </ol>	<p>Initialization overhead when uploading the project to determine the logical addresses.</p>

**Note:** This mode is preferred when the minority of Structure tag members are referenced by a client / server.

**Logical Blocking Mode**

Logical Blocking retrieves all data for a Logix tag in a single request that may be initiated by only one client / server tag. When the data block is received, it is placed in a cache in the driver and then time stamped. Successive client / server tags that belong to the given Logix tag then get their data from this cache. When all tags are updated, a new request is initiated provided that the cache is not old. The cache is old when the current time > cache timestamp + tag scan rate. If this case holds, another block request is made to the device, the cache is refreshed, and the cycle repeats.

Benefits	Detriments
<ol style="list-style-type: none"> <li>1. Contents are retrieved on every read.</li> <li>2. Low device turnaround time because the client / server tags are specified in the packet with the logical address.</li> <li>3. Contains the maximum request per multi-request packet because each request is a fixed size.</li> </ol>	<ol style="list-style-type: none"> <li>1. Initialization overhead when uploading the project to determine the logical addresses.</li> <li>2. If the minority of Logix tags are referenced, it is slower than Logical Non-Blocking Mode (because more data is being accessed from the PLC than referenced in the client / server tags).</li> </ol>

**Note:** This mode is preferred when the majority of Structure tag members are referenced by a client / server.

**See Also:** [Performance Statistics and Tuning](#)

**Symbol Instance vs. Physical Protocol**

Symbol Instance reads are CIP requests wherein the CIP Instance ID is used to specify a Native Tag in a read request. In Non-Blocking Mode, the CIP Member ID may be required to fully qualify the path to structure members and array elements. For example, the CIP Instance ID would represent the structure whereas the CIP Member ID represents the member within the structure. Because of the addition of CIP Member IDs required to fully qualify a client / server tag, requests can vary in size. The deeper nesting of structures means more CIP Member IDs are required to specify a tag and fewer requests fit into a single packet. Symbol Instance reads were introduced in FRN V21.

Physical reads are CIP requests wherein the DMA address is used to specify a Native Tag in a read request. In Non-Blocking Mode, the byte offset may be required to fully qualify the path to structure members and array element. For example, the starting DMA address would represent the structure whereas the byte offset represents the member within the structure. Ultimately the start + offset is the DMA address specified in the request: all requests are fixed in size (unlike Symbol Instance reads). No matter how deep structures are nested, the request is the same size in the packet. Physical reads have been deprecated as of FRN V21.

## Detecting a Change in the Controller Project

The Allen-Bradley ControlLogix Ethernet Driver monitors for project changes and can detect downloads in progress, online edits, and offline edits. When the protocol is set to Logical, users have the option to synchronize the driver's project image with that of the controller project. Synchronization ensures that the driver uses the current logical address for each Native Tag when performing reads and writes.

- **Downloads in Progress:** The driver monitors for both online and offline edits in every request. It detects if a download occurs while actively reading or writing to Native Tags, then follows a project-change procedure depending on its mode. To enable this synchronization, right-click on the device and select **Properties...** In the **Logix Options** group, locate either **Synchronize After Online Edits** or **Synchronize After Offline Edits** and select **Yes**.
- **Synchronize After Online Edits:** The driver monitors for online edits in every request. It detects if an online edit occurs with the controller on the following read or write operation, then follows a project-change procedure depending on its mode. To enable this synchronization, right-click on the device and select **Properties...** In **Logix Options** group, locate **Synchronize After Online Edits** and select **Yes**.
- **Synchronize After Offline Edits:** The driver monitors for offline edits in every request. It detects if an offline edit occurs with the controller on the following read or write operation, then follows a project-change procedure depending on its mode. To enable this synchronization, right-click on the device and select **Properties...** In **Logix Options** group, locate **Synchronize After Offline Edits** and select **Yes**.

## Project Change Procedure (Symbolic Mode)

1. A project change is detected.
2. A message is posted to the Event Log indicating that a change is detected.
3. During project change, the scenario for downloads is as follows:
  - All reads and writes in progress halt and fail.
  - The controller is polled every 2 seconds to monitor for project change completion.
  - The project change is no longer detected.
  - A message is posted to the Event Log indicating that a change is no longer detected.
4. During project change, the scenario for online and offline edits is as follows:
  - The response data is ignored.
  - All reads and writes in progress are retried.
5. The reads and writes resume using Symbolic Mode.

## Project Change Procedure (Logical Modes)

1. A project change is detected.
2. A message is posted to the Event Log indicating that a change is detected.
3. During project change, the scenario for downloads is as follows:
  - All reads and writes in progress halt and fail.
  - The controller is polled every 2 seconds to monitor for project change completion.

- The project change is no longer detected.
  - A message is posted to the Event Log indicating that the change is no longer detected.
4. During project change, the scenario for online and offline edits is as follows:
    - The response data is ignored.
    - All reads and writes in progress are retried.
  5. The reads and writes resume using Symbolic Mode.
  6. If the Synchronize with Controller options are enabled:
    - After 30 seconds of Symbolic Mode, the driver uploads (synchronizes) the project from the controller.
    - The reads and writes resume using Logical Mode with the new logical addresses.
  7. If the Synchronize with Controller options are disabled, the reads and writes resume using Logical Mode with the old logical addresses.

---

## SoftLogix 5800 Connection Notes

For proper operation, no Ethernet-based drivers (such as Ethernet devices, remote devices via Gateway, and so forth) should be installed in RSLinx on the SoftLogix PC. With one or more Ethernet-based drivers installed, requests return with CIP error 0x5, Ext. error 0x1, and CIP error 0x8.

### Connecting to a SoftLogix Soft PLC on the Same PC as the OPC Server

To connect the Allen-Bradley ControlLogix Ethernet Driver to a SoftLogix Soft PLC running on the same PC as the server, follow the instructions below.

1. Ensure that there are no Ethernet-based drivers currently running in RSLinx on the PC.
2. Verify that the **EtherNet/IP Message Module** is installed in the SoftLogix virtual chassis.
3. In the **Device Properties| General** group, locate the device ID value. It should not be "127.0.0.1, 1, <PLC\_CPU\_slot>". The Device ID should be set to "<specific\_IP\_address\_of\_PC>, 1, <PLC\_CPU\_slot>".

For example, if the PC's IP address is 192.168.3.4 and the SoftLogix CPU is in slot 2 of the virtual chassis, then the correct device ID would be "192.168.3.4, 1, 2".

# Index

-

----- 147

## %

%s | CHANNEL STATISTICS 147

%s | DEVICE STATISTICS 147

## 0

0000-Generic Module 26

0x0001 Extended Error Codes 116

0x001F Extended Error Codes 117

0x00FF Extended Error Codes 117

0x01 115

0x02 115

0x03 115

0x04 115

0x05 115

0x06 115

0x07 115

0x08 115

0x09 115

0x0A 115

0x0B 115

0x0C 115

0x0D 115

0x0E 115

0x0F 115

0x10 115

0x11 115

0x12 115

0x13 115

0x14 115

0x15 115

0x1A 115

0x1B 115

0x1C 116

0x1D 116

0x1E 116

0x1F 116  
0x22 116  
0x25 116  
0x26 116  
0x27 116

## 1

1761-NET-ENI 155

## A

Address Descriptions 55  
Address Formats 63  
Addressing Atomic Data Types 66  
Addressing STRING Data Type 68  
Addressing Structure Data Types 68  
Advanced Addressing  
    LTIME 90  
Advanced Addressing: BOOL 70  
Advanced Addressing: DINT 75  
Advanced Addressing: INT 73  
Advanced Addressing: LINT 77  
Advanced Addressing: SINT 71  
Advanced Addressing: UDINT 84  
Advanced Addressing: UINT 83  
Advanced Addressing: ULINT 86  
Advanced Addressing: USINT 81  
Advanced Addressing:LREAL 87  
Advanced Addressing:REAL 79  
Advanced Addressing:TIME 89  
Advanced Addressing:TIME32 88  
Allow Function File Block Writes 24  
Allow Sub Groups 21  
Appendices 150  
Array Block Size 22  
Array Count Limit 24  
Array Tags 36, 63  
ASCII Files 103  
Attempts Before Timeout 19  
Auto-Demotion 19  
Automatic Tag Database Generation 36  
Avg. device turn-around time = <number> (milliseconds) 147  
Avg. packets received/sec = <number>. 147

Avg. packets sent/sec = <number>. 147

Avg. tag reads/sec = <number>. 147

Avg. tags/transaction = <number>. 147

## B

BCD 54

BCD Files 104

Binary Files 99

Block read request failed due to a framing error. | Block size = <number> (bytes), Block name = '<name>'. 126

Block read request failed due to a framing error. | Block size = <number> (elements), Block start address = '<address>'. 126

Block Transfer Files 109

Boolean 54

Byte 54

## C

Channel 0 Communication Status File 113

Channel 1 Communication Status File 113

Channel Assignment 16

Channel Properties – Advanced 16

Channel Properties – Ethernet Communications 15

Channel Properties – General 14

Channel Properties – Write Optimizations 15

Char 54

Choosing a Protocol Mode 164

CIP connection timed out while uploading project information. 124

CIP Error Codes 115

Communication Protocol 13

Communications Routing 160

Communications Timeouts 18

CompactLogix 5300 Addressing for ENI 56

CompactLogix 5300 Addressing for Ethernet 56

CompactLogix 5300 Addressing for Serial Gateway 56

Connect Timeout 18

Connection Path Specification 160

Connection Size 21

Control Files 101

Controller-to-Server Name Conversions 38

Controller not supported. | Vendor ID = <ID>, Product type = <type>, Product code = <code>, Product name = '<name>'. 125

ControlLogix 5000 Addressing 62

ControlLogix 5500 Addressing for ENI 56

ControlLogix 5500 Addressing for Ethernet 56  
ControlLogix 5500 Addressing for Serial Gateway 56  
ControlLogix 5500 Ethernet 154  
ControlLogix Communications Parameters 21  
ControlLogix Database Settings 23  
ControlLogix Options 22  
ControlNet Gateway 157  
ControlNet Gateway Device ID 157  
Counter Files 100  
Create 21  
Create from Device 23  
Create from Import File 23

## D

Data Collection 17  
Data Types Description 54  
Database error. Array tags renamed because they exceed max. character length. | Array tags = '<tags>', Max. length = <number>, New array tags = '<tags>'. 144  
Database error. CIP connection timed out while uploading project information. 124  
Database error. Data type for reference tag unknown. Setting alias tag data type to default. | Reference tag = '<tag>', Alias tag = '<tag>', Default data type = '<type>'. 118  
Database error. Data type not found in tag import file. Tag not added. | Data type = '<type>', Tag name = '<tag>'. 119  
Database error. Encapsulation error occurred during fwd. open request. | Encapsulation error = <code>. 120  
Database error. Encapsulation error occurred during register session request. | Encapsulation error = <code>. 119  
Database error. Encapsulation error occurred while uploading program information. | Program name = '<name>', Encapsulation error = <code>. 121  
Database error. Encapsulation error occurred while uploading project information. | Encapsulation error = <code>. 120  
Database error. Error occurred during forward open request. | CIP error = <code>, Extended error = <code>. 120  
Database error. Error occurred processing alias tag. Tag not added. | Alias tag = '<tag>'. 119  
Database error. Error occurred while uploading program information. | Program name = '<name>', CIP error = <code>, Extended error = <code>. 121  
Database error. Error occurred while uploading project information. | CIP error = <code>, Extended error = <code>. 120  
Database error. Framing error occurred during forward open request. 120  
Database error. Framing error occurred during register session request. 120  
Database error. Framing error occurred while uploading program information. | Program name = '<name>'. 122  
Database error. Framing error occurred while uploading project information. 121  
Database error. Internal error occurred. 121  
Database error. Maximum number of supported programs reached. No tags will be created for this program. | Program name = '<name>', Max. programs = <count>. 144  
Database error. Member data type not found in tag import file. Setting data type to default. | Member data type = '<type>', UDT = '<type>', Default data type '<type>'. 119

Database error. No more connections available for fwd. open request. 124

Database error. PLC5/SLC/MicroLogix devices do not support this function. 148

Database error. Program group name exceeds max. character length. Program group renamed. | Group name = '<name>', Max. length = <number>, New group name = '<name>'. 145

Database error. Tag renamed because it exceeds max. character length. | Tag name = '<tag>', Max. length = <number>, New tag name = '<tag>'. 144

Database error. Unable to resolve CIP data type for tag. Setting to default type. | CIP data type = <type>, Tag name = '<tag>', Default data type = '<type>'. 122

Database Import Method 23

Database status. | Program count = <number>, Data type count = <number>, Imported tag count = <number>. 145

Database status. Building tag projects, please wait. | Tag project count = <number>. 144

Database status. Generating OPC tags. 145

Database status. Importing alias tags. 144

Database status. Importing non-alias tags. 144

Database status. Importing tags from .L5X file. | Schema revision = '<value>', Software revision = '<value>'. 145

Database status. Retrieving controller project. 145

DataHighwayPlus (TM) Gateway Setup 156

Date 54

Default Data Type Conditions 54

Delete 20

Demote on Failure 19

Demotion Period 19

Details. | IP = '<address>', Vendor ID = <vendor>, Product type = <type>, Product code = <code>, Revision = <value>, Product name = '<name>', Product S/N = <number>. 145

Detecting a Change in the Controller Project 166

Device not responding. Local node responded with error. | DF1 status = <code>. 140

Device Properties – Auto-Demotion 19

Device Properties – Redundancy 27

Device Properties – Tag Generation 19

Device Properties – Timing 18

Device tag import aborted. 148

DH+ Gateway Device ID 156, 158

Diagnostics 14

Discard Requests when Demoted 19

Display Descriptions 23

Do Not Scan, Demand Poll Only 18

Double 54

Driver 16

DRIVER STATISTICS 148

Duty Cycle 15

DWord 54

## E

- Elapsed time = <number> (seconds). 145
- Encapsulation Error Codes 115
- Encapsulation error occurred during a request to device. | Encapsulation error = <code>. 133
- Encapsulation error occurred while uploading controller program information. Encapsulation error = <code>. 124
- Encapsulation error occurred while uploading program information. | Program name = '<name>', Encapsulation error = <code>. 123
- Encapsulation error occurred while uploading project information. | Encapsulation error = <code>. 122
- ENI Device ID 156
- ENI DF1/DH+/ControlNet Gateway Communications Parameters 24
- Error Codes 115
- Error occurred during a request to device. | CIP error = <code>, Extended error = <code>. 133
- Error occurred while uploading controller program information. CIP error = <code>, Extended error = <code>. 124
- Error occurred while uploading program information. | Program name = '<name>', CIP error = <code>, Extended error = <code>. 124
- Error occurred while uploading project information. | CIP error = <code>, Extended error = <code>. 123
- Error opening file for tag database import. | OS error = '<code>'. 124
- Errors occurred retrieving controller project. 148
- Ethernet Settings 15
- EtherNet/IP Gateway Setup 158
- Event Log Messages 118

## F

- File Listing 92
- Filtering 24
- FlexLogix 5400 Addressing for Serial Gateway 56
- FlexLogix 5400 Addressing for ENI 56
- FlexLogix 5400 Addressing for Ethernet 56
- Float 54, 103
- Float Files 103
- Frame received from device contains errors. 125
- Framing error occurred while uploading controller program information. 124
- Framing error occurred while uploading program information. | Program name = '<name>'. 124
- Framing error occurred while uploading project information. 123
- Function Files 111

## G

- Generate 20
- Global Tags 64

## H

High-Speed Counter File (HSC) 111

## I

I/O Module Status File (IOS) 114

ID 17

Identification 14, 16

Import file '%s' not found at path '%s'. 148

Import file '%s' not found at path '<empty>'. 149

Import file '<empty>' not found at path '%s'. 149

Import file '<empty>' not found at path '<empty>'. 149

Impose Array Limit 24

Inactivity Watchdog 21

Initial Updates from Cache 18

Initialization transactions = <number>. 147

Input Files 95

Input Words 26

Integer Files 102

Inter-Device Delay 16

Internal driver error occurred. 148

Internal Tags 65

Invalid attributes encountered while uploading program information. All tags for this program will use Symbolic Protocol. | Program name = '<name>'. 143

Invalid or corrupt controller project detected while synchronizing. Synchronization will be retried shortly. 118

Invalid or corrupt controller project detected while synchronizing. Try again later. 148

## L

L5K file is invalid or corrupt. 148

L5X file is invalid or corrupt. 148

LBCD 54

Leading Underscores 38

Limit Name Length 24

Link Address 160

Logix Addressing 56, 62

Logix Advanced Addressing 70

Logix Communications Parameters 21

Logix Database Settings 23

Logix Device IDs 154

Logix Options 22

Logix Tag-Based Addressing 62

Long 54

Long Controller Program & Tag Names 36  
Long Files 105  
Low memory resources. 145, 148

## M

Maximum number of supported programs reached. All tags for this program will use Symbolic Protocol. | Program name = '<name>', Max. programs = <count>. 144  
Memory could not be allocated for tag. | Tag address = '<address>'. 133  
Message Files 109  
Micrologix 1100 Device ID 160  
MicroLogix 1100 Setup 160  
Micrologix Addressing 57  
Micrologix Addressing for ENI 57  
Micrologix Addressing for EtherNet/IP Gateway 57  
MicroLogix Message Files 108  
MicroLogix PID Files 105  
Model 16  
Module 26

## N

Network Adapter 15  
Non-Normalized Float Handling 16

## O

On Device Startup 20  
On Duplicate Tag 20  
On Property Change 20  
Operating Mode 17  
Optimization Method 15  
Optimizing Communications 40  
Optimizing the Application 42  
Ordering of Logix Array Data 69  
Output Files 92  
Output Words 26  
Overview 11  
Overwrite 20

## P

Packets received = <number>. 147

Packets sent = <number>. 147  
Parent Group 21  
Performance Optimizations 40  
Performance Statistics 22  
Performance Statistics and Tuning 42  
Performance Tuning Example 43  
Physical block cache reads = <number>. 146  
Physical block device reads = <number>. 146  
Physical non-block device reads = <number>. 146  
Physical non-block, array block cache reads = <number>. 146  
Physical non-block, array block device reads = <number>. 146  
PID Files 106  
PLC-5 Series Addressing 60  
PLC-5 Series Addressing for ControlNet 60  
PLC-5 Series Addressing for EtherNet/IP Gateway 61  
Port ID 161  
Predefined Term Tags 65  
Preparing for Automatic Tag Database Generation 39  
Program Tags 64  
Project download complete. 141  
Project download detected while synchronizing. Synchronization will be retried shortly. 118  
Project download detected while synchronizing. Try again later. 148  
Project download in progress or no project exists. 141  
Project offline edit detected. Currently using Symbolic addressing. 141  
Project online edit detected. Currently using Symbolic addressing. 141  
Project Options 22  
Protocol 22  
Protocol Mode 22

## R

Read request for tag failed due to a framing error. | Tag address = '<address>'. 125  
Read/Write requests to device resumed. Updating Logical Addresses from device complete. Currently using Logical addressing. 143  
Read/Write requests to device stopped. Updating Logical Addresses from device project. 143  
Read/Write transactions = <number>. 147  
Real-Time Clock File (RTC) 112  
Redundancy 27  
Replace with Zero 16  
Request Size 24  
Request Timeout 18  
Requested CIP connection size is not supported by this device. Automatically falling back to max. size. | Requested size = <number> (bytes), Max. size = <number> (bytes). 142  
Respect Tag-Specified Scan Rate 18  
Routing Examples 162

## S

Scan Mode 17

Serial Gateway Device ID 159

Serial Gateway Setup 159

Setup 12

Short 54

Simulated 17

SLC 500 Fixed I/O Addressing 59

SLC 500 Fixed I/O Addressing for ENI 59

SLC 500 Fixed I/O Addressing for EtherNet/IP Gateway 59

SLC 500 Modular I/O Addressing 59

SLC 500 Modular I/O Addressing for DH+ 59

SLC 500 Modular I/O Addressing for ENI 60

SLC 500 Modular I/O Addressing for EtherNet/IP Gateway 60

SLC 500 Modular I/O Selection Guide 28

SLC 500 Slot Configuration 26

Slot 26

SoftLogix 5800 Addressing 56

SoftLogix 5800 Addressing for Serial Gateway 56

SoftLogix Communications Parameters 21

SoftLogix Database Settings 23

SoftLogix Options 22

SoftLogix Soft PLC Connection Notes 167

Statistic Type 42

Statistics 42

Status Files 99

String 54

String Files 104

Structure Tag Addressing 64

Supported Devices 12

Symbol instance block cache reads = <number>. 146

Symbol instance block device reads = <number>. 146

Symbol instance non-block device reads = <number>. 146

Symbol instance non-block, array block cache reads = <number>. 146

Symbol instance non-block, array block device reads = <number>. 146

Symbolic device reads = <number>. 145

Symbolic, array block cache reads = <number>. 146

Symbolic, array block device reads = <number>. 145

Synchronize After Offline Edits 22

Synchronize After Online Edits 22

## T

- Tag Counts 14, 18
- Tag Generation 19
- Tag Hierarchy 36
- Tag Import File 23
- Tag Scope 64
- Tags read = <number>. 146
- TCP/IP Port 21, 24
- Terminate String Data at LEN 22
- The following errors occurred uploading controller project from device. Resorting to symbolic protocol. 141
- The following errors occurred uploading controller project from device. Resorting to Symbolic Protocol. 118
- The tag import filename is invalid, file paths are not allowed. 142
- Timeouts to Demote 19
- Timer Files 100
- Timing 18

## U

- Unable to read block. | Block size = <number> (bytes), Tag name = '<tag>', CIP error = <code>, Extended error = <code>. 127
- Unable to read block. | Block size = <number> (elements), Block start address = '<address>', CIP error = <code>, Extended error = <code>. 127
- Unable to read block. | Block size = <number> (elements), Starting address = '<address>', DF1 status = <code>, Extended status = <code>. 135
- Unable to read block. | Block size = <number> (elements), Starting address = '<address>', DF1 status = <code>. 137
- Unable to read block. Block deactivated. | Block size = <number> (bytes), Tag name = '<tag>'. 132
- Unable to read block. Block deactivated. | Block size = <number> (elements), Block start address = '<address>', CIP error = <code>, Extended error = <code>. 139
- Unable to read block. Block deactivated. | Block size = <number> (elements), Block start address = '<address>'. 132
- Unable to read block. Block does not support multi-element arrays. Block deactivated. | Block size = <number> (elements), Block start address = '<address>'. 130
- Unable to read block. Controller tag data type unknown. Block deactivated. | Block size = <number> (elements), Block start address = '<address>', Data type = <type>. 128
- Unable to read block. Data type is illegal for this block. Block deactivated. | Block size = <number> (elements), Block start address = '<address>', Data type = '<type>'. 129
- Unable to read block. Data type not supported. Block deactivated. | Block size = <number> (elements), Block start address = '<address>', Data type = '<type>'. 128
- Unable to read block. Frame received contains errors. | Block size = <number> (elements), Starting address = '<address>'. 134
- Unable to read block. Internal memory is invalid. Block deactivated. | Block size = <number> (elements), Block start address = '<address>'. 139
- Unable to read block. Internal memory is invalid. Tag deactivated. | Tag address = '<address>'. 139
- Unable to read block. Native tag size mismatch. | Block size = <number> (bytes), Block name = '<name>'. 131
- Unable to read block. Native tag size mismatch. | Block size = <number> (elements), Block start address =

- '<address>'. 131
- Unable to read block. Tags deactivated. | Block size = <number> (elements), Starting address = '<address>', DF1 status = <code>, Extended status = <code>. 134, 136
- Unable to read function file from device. Frame received contains errors. | Function file = '<name>'. 134
- Unable to read function file from device. Tags deactivated. | Function file = '<name>', DF1 status = <code>, Extended status = <code>. 134
- Unable to read function file. | Function file = '<name>', DF1 status = <code>, Extended status = <code>. 135
- Unable to read function file. | Function file = '<name>', DF1 status = <code>. 138
- Unable to read function file. Tags deactivated. | Function file = '<name>', DF1 status = <code>. 136
- Unable to read tag. | Tag address = '<address>', CIP error = <code>, Extended error = <code>. 127
- Unable to read tag. Controller tag data type unknown. Tag deactivated. | Tag address = '<address>', Data type = <type>. 127
- Unable to read tag. Data type is illegal for this tag. | Tag address = '<address>', Data type = '<type>'. 139
- Unable to read tag. Data type is illegal for this tag. Tag deactivated | Tag address = '<address>', Data type = '<type>'. 129
- Unable to read tag. Data type not supported. Tag deactivated. | Tag address = '<address>', Data type = '<type>'. 128
- Unable to read tag. Internal memory is invalid. | Tag address = '<address>'. 139
- Unable to read tag. Native tag size mismatch. | Tag address = '<address>'. 131
- Unable to read tag. Tag deactivated. | Tag address = '<address>'. 132
- Unable to read tag. Tag does not support multi-element arrays. Tag deactivated. | Tag address = '<address>'. 130
- Unable to retrieve the identity for device. All tags will use Symbolic Protocol. | CIP error = <code>, Extended error = <code>. 141
- Unable to retrieve the identity for device. All tags will use Symbolic Protocol. | Encapsulation error = <code>. 141
- Unable to retrieve the identity for device. Frame received contains errors. All tags will use Symbolic Protocol. 142
- Unable to write to address. | Address = '<address>', DF1 status = <code>, Extended status = <code>. 136
- Unable to write to address. | Address = '<address>', DF1 status = <code>. 138
- Unable to write to address. Frame received contains errors. | Address = '<address>'. 135
- Unable to write to address. Internal memory is invalid. | Tag address = '<address>'. 139
- Unable to write to address. Local node responded with error. | Function file = '<name>', DF1 status = <code>. 140
- Unable to write to function file. | Function file = '<name>', DF1 status = <code>, Extended status = <code>. 137
- Unable to write to function file. | Function file = '<name>', DF1 status = <code>. 138
- Unable to write to function file. Frame received contains errors. | Function file = '<name>'. 135
- Unable to write to function file. Local node responded with error. | Function file = '<name>', DF1 status = <code>. 140
- Unable to write to tag. | Tag address = '<address>', CIP error = <code>, Extended error = <code>. 126
- Unable to write to tag. | Tag address = '<address>'. 131
- Unable to write to tag. Controller tag data type unknown. | Tag address = '<address>', Data type = <type>. 127
- Unable to write to tag. Data type is illegal for this tag. | Tag address = '<address>', Data type = '<type>'. 129
- Unable to write to tag. Data type not supported. | Tag address = '<address>', Data type = '<type>'. 128
- Unable to write to tag. Native tag size mismatch. | Tag address = '<address>'. 130
- Unable to write to tag. Tag does not support multi-element arrays. | Tag address = '<address>'. 129
- Unable to write to tag. Value written contains a syntax error. | Tag address = '<address>', Expected format = '<format>'. 143

Unable to write to tag. Value written is out of range. | Tag address = '<address>'. 143  
Unexpected offset encountered for tag. | Tag address = '<address>'. 141  
Unexpected offset encountered for tag. Tag will use Symbolic protocol. | Tag address = '<address>'. 140  
Unexpected offset/span encountered for tag. | Tag address = '<address>'. 141  
Unknown error occurred. 145, 148  
Unmodified 16

## V

Value not supported for an XML element on this model. Automatically setting to new value. | Value = '<value>', XML element = '{<namespace><element>', Model = '<model>', New value = '<value>'. 149

## W

Word 54  
Write All Values for All Tags 15  
Write Only Latest Value for All Tags 15  
Write Only Latest Value for Non-Boolean Tags 15  
Write request failed due to a framing error. | Tag address = '<address>'. 125

## X

XML element failed post-schema validation. Importing tags from device is not supported for model. Use alternative element. | XML element = '{<namespace><element>', Unsupported model = '<model>', Alternative XML element = '{<namespace><element>'. 149