

SESSION ID: CA1515B

# Accelerating Digital Design via the Cloud

**SPEAKER(s):**

**NICOLAS PERRIN**

FOUNDER OF PERRINN 424

---

# GOALS

Bring awareness to PERRINN 424

How you can follow and participate

How Onshape has made this possible



# PERRINN 424: Why

- Obsession for performance, speed and records
- Extensive experience at the top level of motorsport
- Commitment to advancing innovation

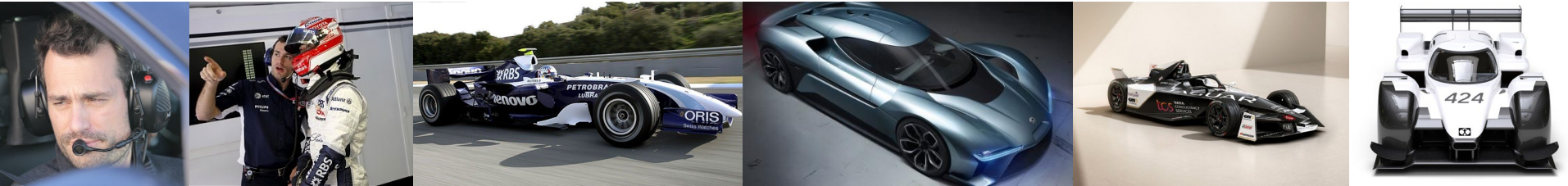

# PERRINN 424: The Challenge

1983  
PORSCHE 956  
6:11.13

2018  
PORSCHE 919  
5:19.546

202x  
PERRINN 424  
5:07.5 (digital)



Petrol era

Hybrid era

Electric era

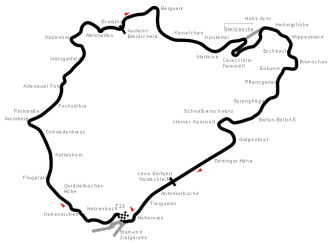

# PERRINN 424: How

A network of talented **people** + **software** companies

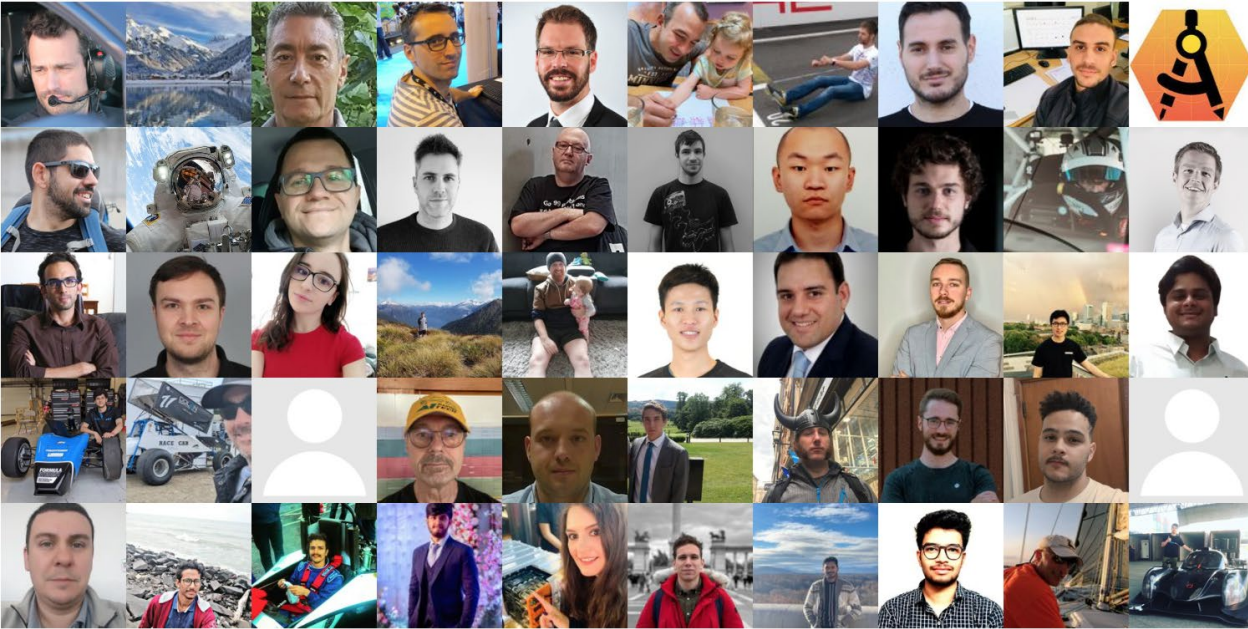

# PERRINN 424: Support and Invest



[PERRINN.com](https://PERRINN.com)

Chat with us

Invest in PERRINN digital shares

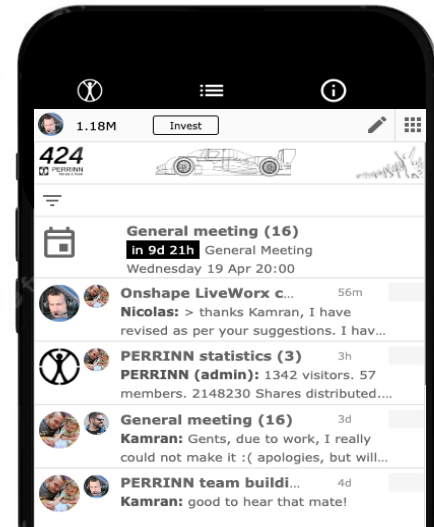

# 424 TECHNICAL SPECIFICATION

"424 has to become and remain the fastest electric car in the world."

## TECHNICAL SPECIFICATION:

- Chassis made entirely of composite material
- Weight: 1,000kg (500kg chassis & 500kg powertrain)
- 3 Formula E motors (one front, two rear)
- Power: 750kW (250 front, 500 rear)
- Transmission: Four-Wheel-Drive, single speed
- Battery: 50 kWh, centrally mounted
- Acceleration: 0 - 100kph in 2.0 sec
- Top speed: 360kph
- Advanced aerodynamics (DRS)

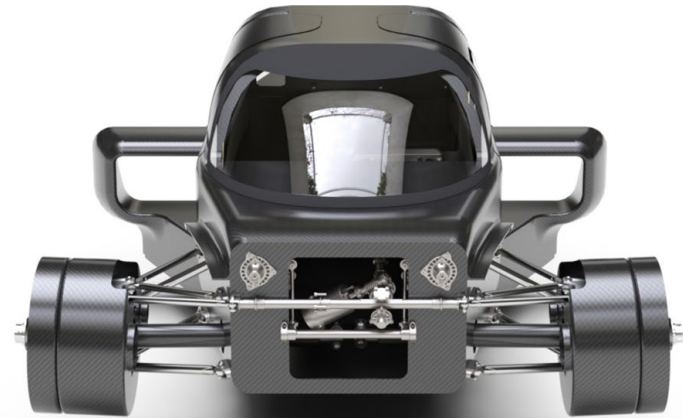

# DIGITAL TWIN

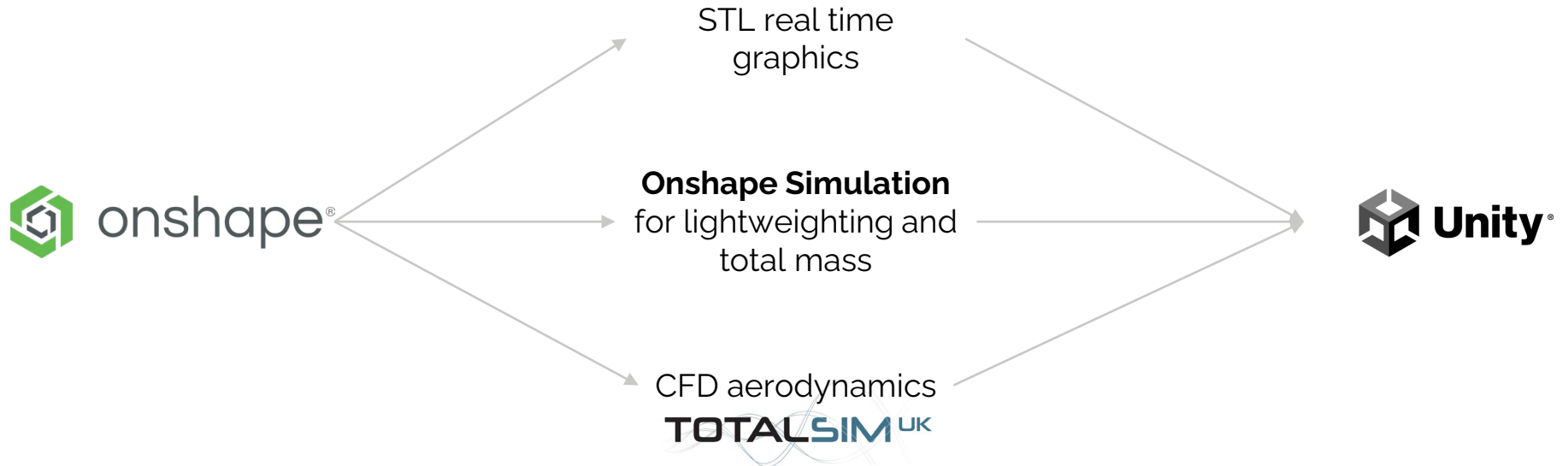



# DIGITAL TWIN: Aerodynamic development

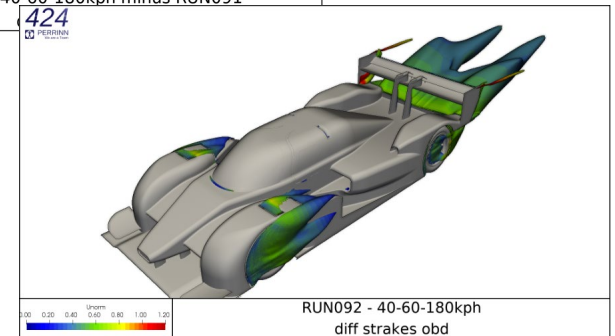
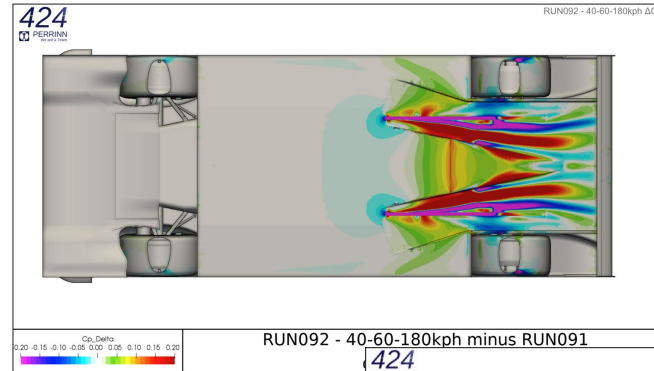
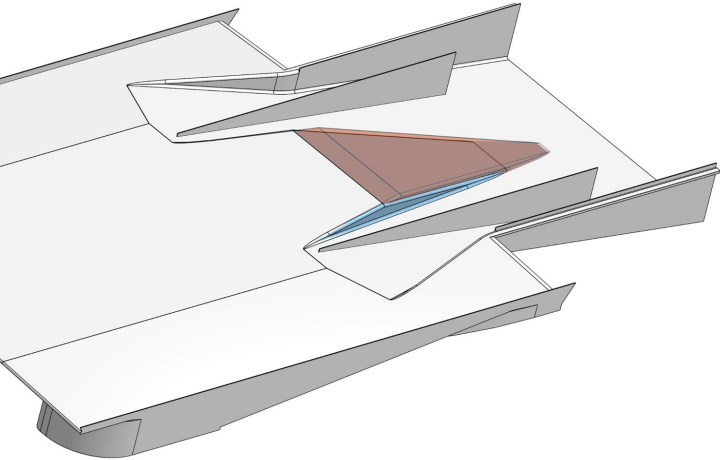

424 generates aerodynamic efficiency of

5.5:1

6.5:1 with DRS activated.

# DIGITAL TWIN: Real time driving simulation

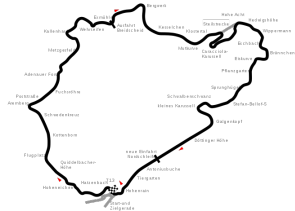

→ **Laptime**  
**5:07.50**



What happens when we push the limits

# DIGITAL TWIN: Aerodynamic instability



# DIGITAL TWIN: Engineering simulations

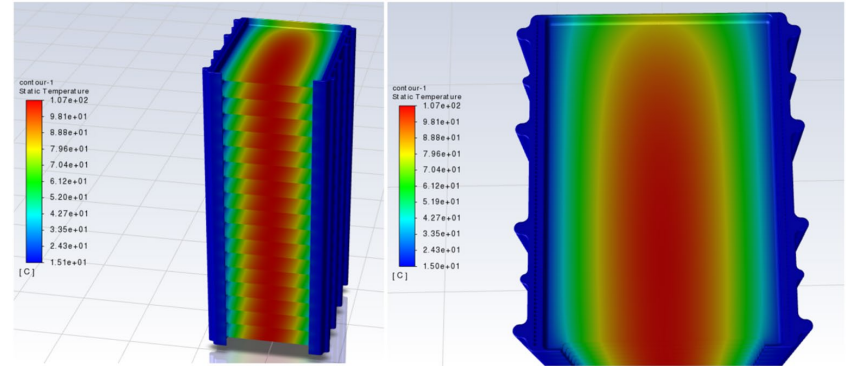
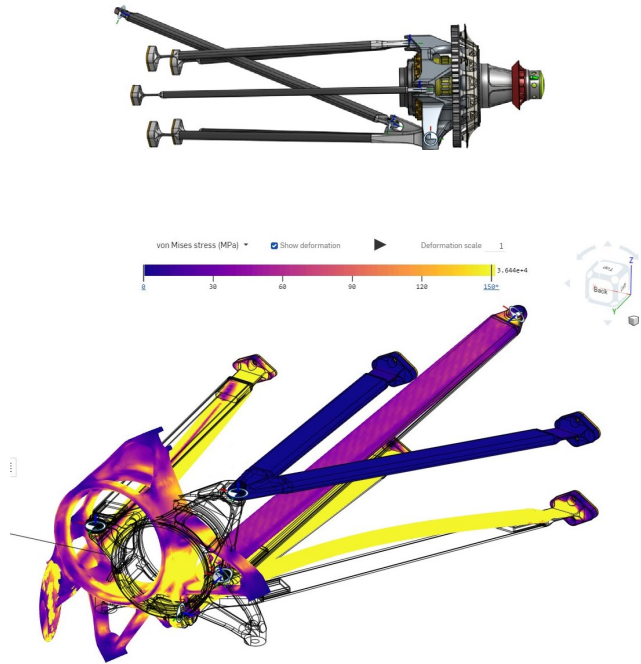

# DIGITAL TWIN: Rendering studio

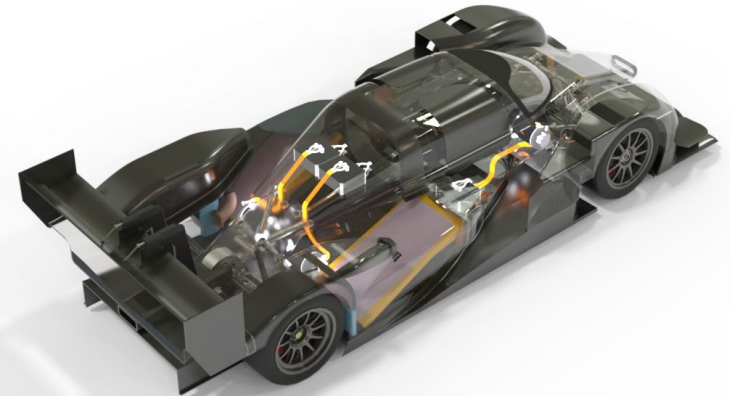
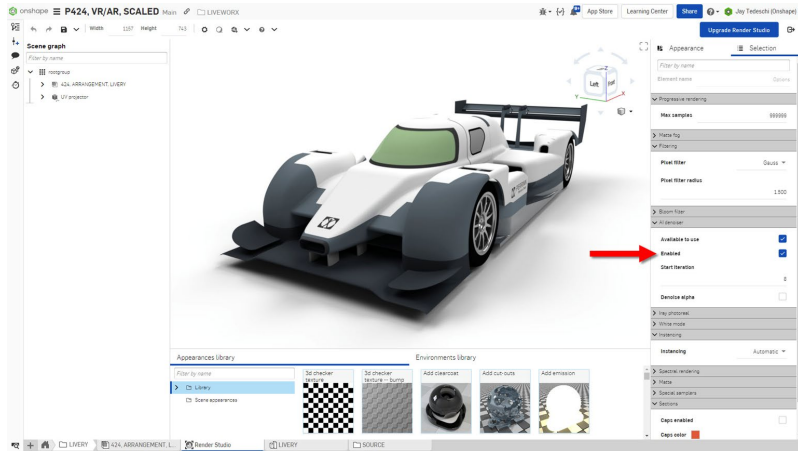

# DESIGN IN THE CLOUD

Rear casing stiffening  
brace has been designed  
by

4 people

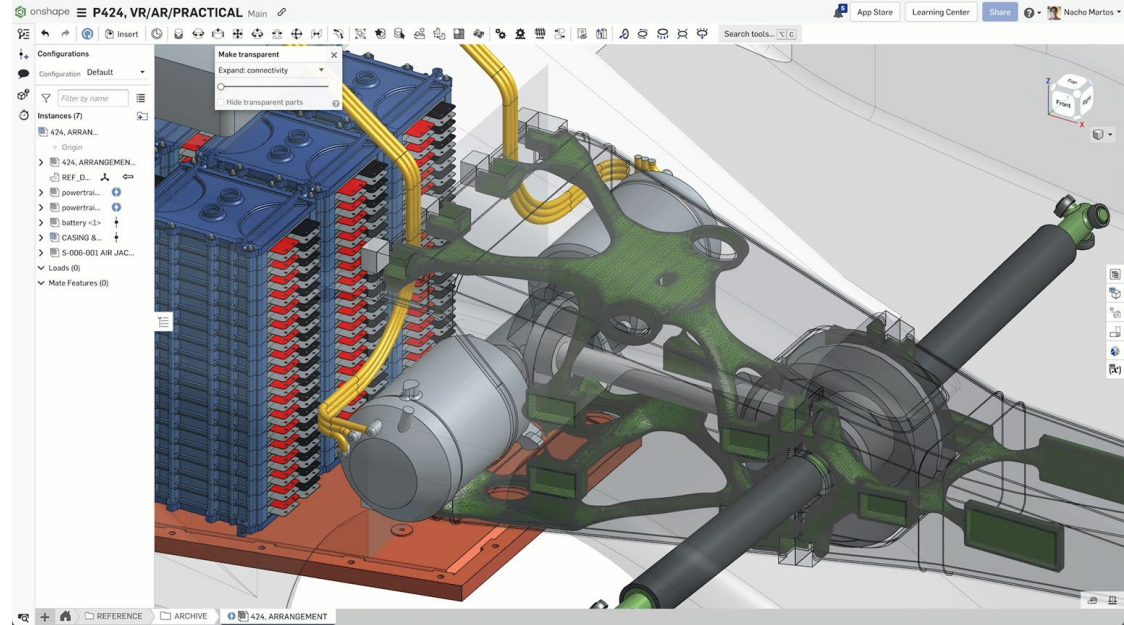

Located on 3 continents

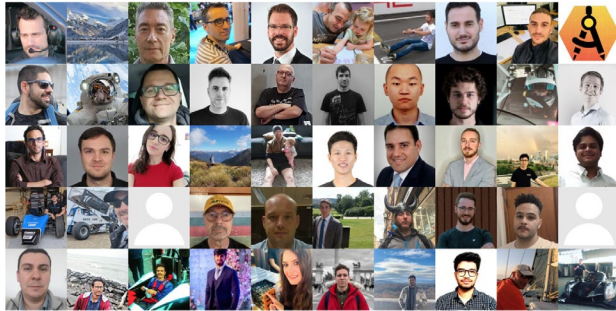

# DESIGN IN THE CLOUD

PERRINN  
We are a Team



Name	
	PERRINN 424 architecture
	♀ Main

♀ Main



Onshape empowers our distributed team.

- Collaboration tools
- Branching and merging
- Public data sharing

# PERRINN 424: Support and Invest



[PERRINN.com](https://PERRINN.com)

Chat with us

Invest in PERRINN digital shares

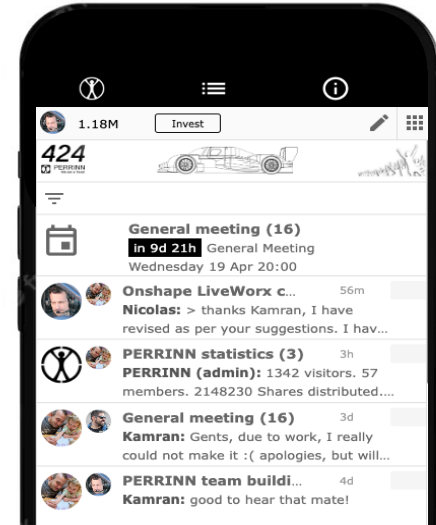



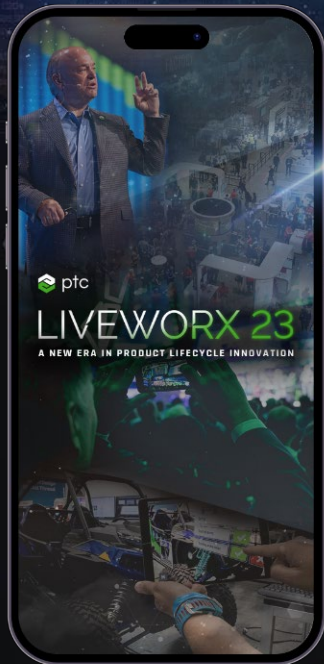

**Please fill out the session survey.**

Take your post-session survey(s) either in the event mobile app or via email post-event.

Your feedback provides us with valuable information on how to shape future content strategy for the event!

**PROVIDE SESSION FEEDBACK**



ptc

# LIVEWORX

A NEW ERA IN PRODUCT LIFECYCLE INNOVATION

# THANK YOU

[LIVEWORX.COM](http://LIVEWORX.COM) | [#LIVEWORX](https://twitter.com/LIVEWORX)

[ptc.com](http://ptc.com)

